

APJ ABDUL KALAM
TECHNOLOGICAL
UNIVERSITY

SEMESTER VI

KTU



ECT302	ELECTROMAGNETICS	CATEGORY	L	T	P	CREDIT
		PCC	3	1	0	4

Preamble: This course aims to impart knowledge on the basic concepts of electric and magnetic fields and its applications.

Prerequisite: MAT102 Vector Calculus

Course Outcomes: After the completion of the course the student will be able to

CO 1 K2	To summarize the basic mathematical concepts related to electromagnetic vector fields.
CO 2 K3	Analyse Maxwell's equation in different forms and apply them to diverse engineering problems.
CO3 K3	To analyse electromagnetic wave propagation and wave polarization
CO4 K3	To analyse the characteristics of transmission lines and solve the transmission line problems using Smith chart.
CO5 K3	To analyse and evaluate the propagation of EM waves in Wave guides.

Mapping of course outcomes with program outcomes

	PO 1	PO 2	PO 3	PO 4	PO 5	PO 6	PO 7	PO 8	PO 9	PO 10	PO 11	PO 12
CO1	3	3	1	1								2
CO2	3	3	1	1								2
CO3	3	3	1	1								2
CO4	3	3	1	1								2
CO5	3	3	1	1								2

Assessment Pattern

Bloom's Category		Continuous Assessment Tests		End Semester Examination
		1	2	
Remember	K1			
Understand	K2	20	20	40
Apply	K3	30	30	60
Analyse				
Evaluate				
Create				

Mark distribution

Total Marks	CIE	ESE	ESE Duration
150	50	100	3 hours

Continuous Internal Evaluation Pattern:

Attendance	: 10 marks
Continuous Assessment Test (2 numbers)	: 25 marks
Assignment/Quiz/Course project	: 15 marks

End Semester Examination Pattern: There will be two parts; Part A and Part B. Part A contain 10 questions with 2 questions from each module, having 3 marks for each question. Students should answer all questions. Part B contains 2 questions from each module of which student should answer any one. Each question can have maximum 2 sub-divisions and carry 14 marks.

Course Level Assessment Questions

Course Outcome 1 (CO1): To summarize the basic mathematical concepts related to electromagnetic vector fields. (K2)

1. State and explain divergence theorem. Give a geometrical explanation.
2. Find the curl of the vector $A = 2r\cos\phi a_\rho + r a_\phi$ in cylindrical coordinates
3. Show that $\text{curl grad } F$ and $\text{div curl } F$ are identically zero.
4. Show that $V = \frac{1}{4\pi\epsilon_0} \frac{Q}{r}$ where $r = (x^2 + y^2 + z^2)^{1/2}$ satisfies Laplace's equation.

Course Outcome 2 (CO2): Analyse Maxwell's equation in different forms and apply them to diverse engineering problems. (K3)

1. State and explain Maxwell's equations in the integral and differential forms.
2. Derive the solution of uniform plane wave in lossy dielectric medium.

Course Outcome 3 (CO3): To analyse electromagnetic wave propagation and wave polarization (K3)

1. Derive an expression for reflection coefficient of a plane wave under oblique incidence with parallel polarization at a dielectric interface.

2. Explain wave polarization and different polarisation with example.
3. Derive the expression for Brewster angle for parallel polarised wave.

Course Outcome 4 (CO4): To analyse the characteristics of transmission lines and solve the transmission line problems using Smith chart. (K3)

1. A transmission line of length 0.2λ and characteristic impedance 100Ω is terminated with a load impedance of $50+200j$. Find input impedance, reflection coefficient at load end, reflection coefficient at the input end and VSWR.
2. A lossless transmission line has a characteristic impedance of 50Ω and phase constant of 3 Rad/ m at 100 MHz . Find Inductance per meter and Capacitance per meter of the transmission line.
3. A $50 + j200 \Omega$ load is connected to a 100Ω lossless transmission line. Using Smith chart, find i. Reflection coefficient at load ii. VSWR

Course Outcome 5 (CO5): To analyse and evaluate the propagation of EM waves in Wave guides.(K3)

1. For TE₁₀ mode of propagation in a rectangular wave guide, with length 8cm and 6 cm respectively, find the following when frequency of operation is 6 GHz .
 - i. Cut off frequency
 - ii. Cut off wavelength
 - iii. Guide wavelength
 - iv. Phase constant
 - v. Phase velocity
 - vi. Group velocity
 - vii. Wave impedance
2. A rectangular wave guide has a dimension of $3\text{cm} \times 5\text{cm}$, and is operating at a frequency of 10 GHz . Calculate the cutoff wavelength, cutoff frequency, guide wavelength, phase velocity and group velocity. and the wave impedance for TE₁₀ mode.
3. Derive the expression for Electric and magnetic field intensities for TM mode of propagation of rectangular waveguide.

SYLLABUS**MODULE 1 :**

Introduction to Electromagnetic Theory. Review of vector calculus- curl, divergence gradient. Rectangular, cylindrical and spherical coordinate systems. Expression of curl divergence and Laplacian in cartesian, cylindrical and spherical coordinate system. Electric field and magnetic field, Review of Coulomb's law, Gauss law and Amperes current law. Poisson and Laplace equations, Determination of E and V using Laplace equation.

MODULE 2 :

Derivation of capacitance and inductance of two wire transmission line and coaxial cable. Energy stored in Electric and Magnetic field. Displacement current density, continuity equation. Magnetic vector potential. Relation between scalar potential and vector potential. Maxwell's equation from fundamental laws. Boundary condition of electric field and magnetic field from Maxwells equations. Solution of wave equation.

MODULE 3 :

Propagation of plane EM wave in perfect dielectric, lossy medium, good conductor, media-attenuation, phase velocity, group velocity, skin depth. Reflection and refraction of plane electromagnetic waves at boundaries for normal & oblique incidence (parallel and perpendicular polarization), Snell's law of refraction, Brewster angle.

MODULE 4 :

Power density of EM wave, Poynting vector theorem. Polarization of electromagnetic wave- linear, circular and elliptical polarisation. Uniform lossless transmission line - line parameters. Transmission line equations, Voltage and Current distribution of a line terminated with load .Reflection coefficient and VSWR. Derivation of input impedance of transmission line.

MODULE 5 :

Transmission line as circuit elements (L and C). Development of Smith chart - calculation of line impedance and VSWR using smith chart.

The hollow rectangular wave guide –modes of propagation of wave-dominant mode, group velocity and phase velocity -derivation and simple problems only

Text Books

1. John D. Kraus, Electromagnetics, 5/e, TMH, 2010.
2. Mathew N O Sadiku, Elements of Electromagnetics, Oxford University Press, 6/e, 2014.
3. William, H. Hayt, and John A. Buck. Engineering Electromagnetics. McGraw-Hill, 8/e McGraw-Hill, 2014.

Reference Books

1. Edminister, "Schaum's Outline of Electromagnetics", 4/e, McGraw-Hill, 2014.
2. Jordan and Balmain, Electromagnetic waves and Radiating Systems, PHI, 2/e, 2013
3. Martin A Plonus, Applied Electromagnetics, McGraw Hill, 2/e, 1978.
4. Nannapaneni Narayana Rao, Elements of Engineering Electromagnetics, Pearson, 6/e, 2006.
5. Umran S. Inan and Aziz S. Inan, Engineering Electromagnetics, Pearson, 2010.

Course Contents and Lecture Schedule

No	Topic	No. of Lectures
1	Module 1	
1.1	Introduction to Electromagnetic Theory. Review of vector calculus- curl, divergence gradient.	3
1.2	Rectangular, cylindrical and spherical coordinate systems. Expression of curl divergence and Laplacian in cartesian, cylindrical and spherical coordinate system.	3
1.3	Electric field and magnetic field. Review of Coulomb's law, Gauss law and Amperes current law.	2
1.4	Poisson and Laplace equations, Determination of E and V using Laplace equation.	2
2	Module 2	
2.1	Derivation of capacitance and inductance of two wire transmission line and coaxial cable.	2
2.2	Energy stored in Electric and Magnetic field.	1
2.3	Displacement current density, continuity equation. Magnetic vector potential. Relation between scalar potential and vector potential.	3
2.4	Maxwell's equation from fundamental laws.	2
	Boundary condition of electric field and magnetic field from Maxwell's equations.	1
2.5	Solution of wave equation	1
3	Module 3	
3.1	Propagation of plane EM wave in perfect dielectric, lossy medium, good conductor, media-attenuation, phase velocity, group velocity, skin depth.	4
3.2	Reflection and refraction of plane electromagnetic waves at boundaries for normal & oblique incidence (parallel and perpendicular polarization), Snell's law of refraction, Brewster angle.	4
4	Module 4	

4.1	Power density of EM wave, Poynting vector theorem.	2
4.2	Polarization of electromagnetic wave-linear, circular and elliptical polarisation.	2
4.3	Uniform lossless transmission line - line parameters. Transmission line equations	3
4.4	Voltage and Current distribution of a line terminated with load .Reflection coefficient and VSWR.Derivation of input impedance of transmission line.	3
5	Module 5	
5.1	Transmission line as circuit elements (L and C).	1
5.2	Development of Smith chart - calculation of line impedance and VSWR using smith chart.	3
5.3	The hollow rectangular wave guide –modes of propagation of wave-dominant mode, group velocity and phase velocity -derivation and simple problems only	4

Assignments:**Model Question paper****APJ ABDUL KALAM TECHNOLOGICAL UNIVERSITY****SIXTH SEMESTER B.TECH DEGREE EXAMINATION, (Model Question Paper)****Course Code: ECT302****Course Name: ELECTROMAGNETICS**

Max. Marks: 100

Duration: 3 Hours

PART A

Answer ALL Questions. Each Carries 3 mark.

- 1 Define Curl of a vector field. Explain its physical significance. K2
- 2 Obtain Coulomb's law from Gauss' law K2
- 3 Write Poisson's and Laplace's Equation with applications K1
- 4 A Parallel plate capacitor with plate area of 5cm^2 and a plate separation of 3mm K3
has a voltage $50\sin 10^3 t$ Volt applied to its plates. Calculate the displacement current assuming $\epsilon = 2\epsilon_0$.
- 5 List all Maxwell's equations in integral form K1

- 6 Explain the significance of skin depth. K2
- 7 What is Snell's law? K1
- 8 What is wave polarisation? What are the different types of polarisation? K1
- 9 State the relation between standing wave ratio and reflection coefficient. K1
- 10 How a quarter wave dissipationless line can be used for impedance matching?. K2

PART – B

Answer one question from each module; each question carries 14 marks.

Module - I

- 11 a. Derive the equation for curl of a vector field in Cartesian co-ordinate system. 7
CO1
K2
- b. A Spherical volume charge distribution is given by 7

$$\rho = \rho_0 \left(1 - \frac{r^2}{a^2}\right); r \leq a$$

$$\rho = 0; r > a$$
 CO1
 Find the electric field intensity E; i) inside and ii) outside the charge distribution K3

OR

- 12 Interpret the following 7
CO1
 i) $\nabla \times B = \mu_0 J$ ii) $\nabla \times E = 0$ where B and J stands for magnetic flux density and electric current density K3
- b. Apply Ampere's circuital law to the case of an infinitely long coaxial cable carrying a uniformly distributed total current I. Compute the magnetic field intensity existing in different parts of the cable. 7
CO1
K3

Module - II

- 13 a. Derive the expression of capacitance of two wire transmission line. 7
CO2
K2
- b. Show that the energy stored in a system of n point charges is given by 7

$$W_E = \frac{1}{2} \sum_{i=1}^n Q_i V_i \text{ where } V_i \text{ is the potential of the point charge } Q_i.$$

CO2

K3

OR

- 14a Define vector magnetic potential and show that $B = \nabla \times A$, where B is the magnetic flux density and A is the vector magnetic potential at any point. 7
CO2
K2

- b State and prove boundary conditions for E and H in accordance with Maxwell's equations. 7
CO2
K2

Module - III

- 15 Derive the expression for reflection coefficient for a wave of perpendicular polarization, travelling from one medium to another at oblique incidence. 7
a. CO3
K2

- b. In a lossy dielectric medium, characteristic impedance of the medium is $173 + j100 \Omega$, Expression of Magnetic field of a plane wave is given by $10 e^{-\alpha x} \cos(\omega t - 0.5x) a_z$ A/m. Find 7
CO3
K3

i. Direction of propagation

ii. Loss tangent

iii. Attenuation constant

iv. Phase constant

v. Skin depth

OR

- 16 a Derive continuity equation from fundamental laws. 7
CO3
K2

- b Find the skin depth, δ at a frequency of 1.6 MHz in aluminium, where $\sigma = 38.2 \text{ MS/m}$ and $\mu_r = 1$. Also find the propagation constant, γ and the wave

		7
velocity v .		CO3
		K3

Module - IV

- 17a Derive the equation for transmission and reflection coefficients of an electromagnetic wave incident normally on the boundary between two different regions. 7
CO4
K2
- b Derive an expression for net outward power flow associated with an electromagnetic wave, from a surface. 7
CO4
K2

OR

- 18 Derive standard Transmission line equations. 7
a. CO4
K2
- b. Given two dielectric media, the first medium is free space and the second medium has $\epsilon_2 = 4\epsilon_0$ and $\mu = \mu_0$. Find the reflection coefficient for oblique incidence at $\theta_1 = 30^\circ$ for i) perpendicular polarisation and ii) parallel polarisation 7
CO4
K3

Module - V

- 19 A rectangular wave guide has a dimension of 3cm x 5cm , and is operating at a 7
a. frequency of 10 GHz . Calculate the cutoff wavelength, cutoff frequency , guide CO5
wavelength , phase velocity and group velocity . and the wave impedance for K3
TE10 mode.
- b. At a frequency of 80 MHz, a lossless transmission line has a characteristic 7
impedance of 300Ω and a wavelength of 2.5m. Find: CO5
i) L ii) C iii) If the line is terminated with a parallel combination of 200Ω and 5pF, determine the reflection co-efficient and the standing wave ratio. K3

OR

- 20 a A $50 + j200 \Omega$ load is connected to a 100Ω lossless transmission line . Using smith 7
chart , find

- | | | | |
|-----------------------------------|--|----------------------|-----|
| i. Reflection coefficient at load | ii. VSWR | iii. Load admittance | CO5 |
| | | | K3 |
| b | Derive the expression for Electric and magnetic field intensities for TM mode of propagation of rectangular waveguide. | | 7 |
| | | | CO5 |
| | | | K2 |

APJ ABDUL KALAM
TECHNOLOGICAL
UNIVERSITY

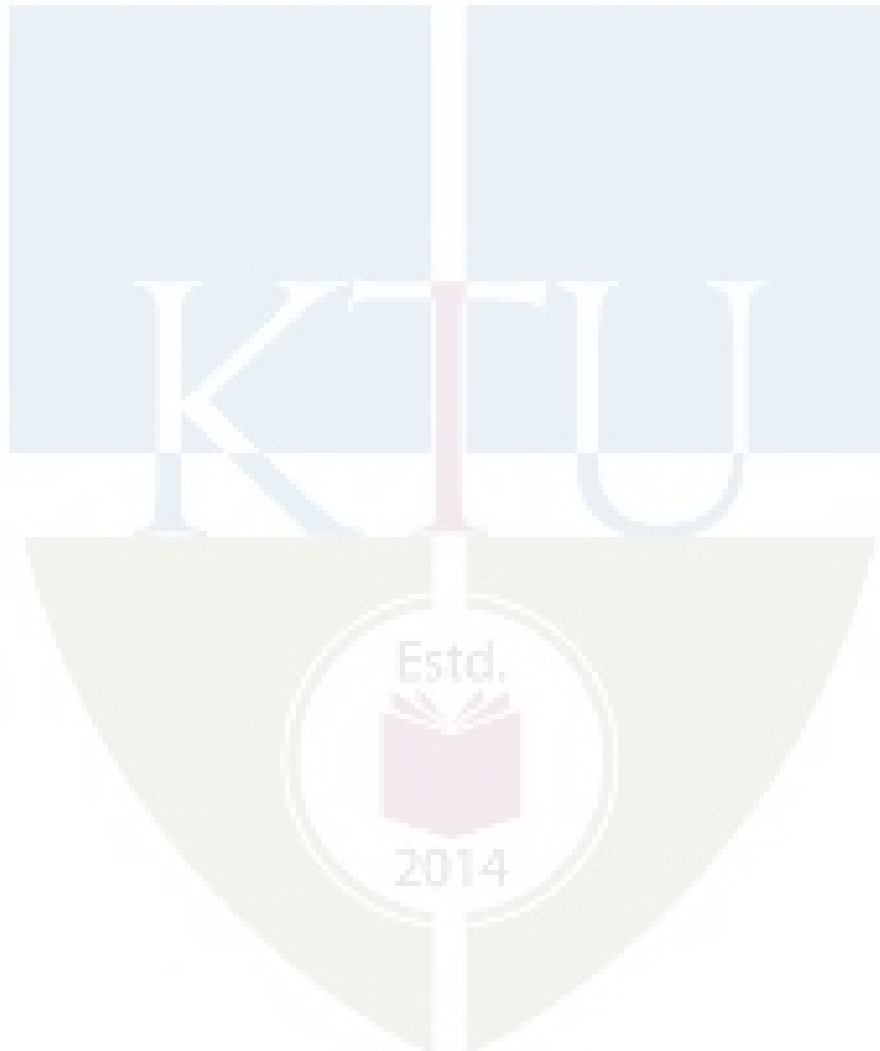

ECT304	VLSI CIRCUIT DESIGN	CATEGORY	L	T	P	CREDIT
		PCC	3	1	0	4

Preamble: This course aims to impart the knowledge of VLSI design methodologies and Digital VLSI circuit design.

Prerequisite:

1. ECT201 Solid State Devices
2. ECT202 Analog Circuits
3. ECT 203 Logic Circuit Design.

COURSE OUTCOMES.

After the completion of the course the student will be able to:

CO1	Explain the various methodologies in ASIC and FPGA design.
CO2	Design VLSI Logic circuits with various MOSFET logic families.
CO3	Compare different types of memory elements.
CO4	Design and analyse data path elements such as Adders and multipliers.
CO5	Explain MOSFET fabrication techniques and layout design rules.

Mapping of course outcomes with program outcomes:

	PO1	PO2	PO3	PO4	PO5	PO6	PO7	PO8	PO9	PO10	PO11	PO12
CO1	3		3									2
CO2	3	2	3									2
CO3	3	2	3									2
CO4	3	2	3									2
CO5	3		2									2

Assessment Pattern:

Bloom's Category	Continuous Assessment Tests		End Semester Examination
	1	2	
Remember	10	10	20
Understand	20	20	40
Apply	20	20	40
Analyze			
Evaluate			
Create			

Mark distribution:

Total Marks	CIE	ESE	Duration
150	50	100	3Hrs

Continuous Internal Evaluation Pattern:

Attendance : 10 marks
 Continuous Assessment Test (2 numbers) : 25 marks
 Assignments : 15 marks.

End Semester Examination Pattern**Maximum Marks : 100****Time : 3 hours**

End Semester Examination Pattern: There will be two parts; Part A and Part B. Part A contain 10 questions with 2 questions from each module, having 3 marks for each question. Students should answer all questions. Part B contains 2 questions from each module of which student should answer any one. Each question can have maximum 2 sub-divisions and carry 14 marks. Mark patterns are as per the syllabus with 75% for theory and 25% for logical/numerical problems.

Course Level Assessment Questions.**CO1:**

1. Differentiate between full custom and semi-custom ASIC.
2. With a neat flow chart, explain ASIC design flow.
3. Describe Gate array based ASIC with neat diagram.
4. What are the processes involved in Soc design.

CO2:

1. With a neat diagram explain static and transient analysis of CMOS inverter
2. Realize the given logic function using static CMOS logic and transmission gate logic.
3. Compare the advantages and disadvantages of static and dynamic circuits.

CO3:

1. Compare different ROM structures.
2. Compare static and dynamic RAM structures.
3. Compare the advantages of three transistor and one transistor DRAM cell.

CO4:

1. Design a full adder with static CMOS logic
2. Compare the delay of Carry-Bypass adder, Linear Carry- Select adder, Square- root carry-select adder.

CO5:

1. Explain how electronic grade silicon (EGS) is developed .
2. Explain the necessity of single crystalline silicon in VLSI fabrication and how single crystal silicon is made.
3. Explain diffusion and ion implantation techniques.
4. Explain the advantages of SiO₂ and the oxidation techniques.

Syllabus**Module 1: VLSI Design Methodologies.**

Introduction: Moore's law .ASIC design, Full custom ASICs, Standard cell based ASICs, Gate array based ASICs, SoCs, FPGA devices, ASIC and FPGA Design flows, Top-Down and Bottom-Up design methodologies. Logical and Physical design. Speed power and area considerations in VLSI design

Module 2: Static CMOS Logic Design

MOSFET Logic Design - NMOS Inverter (Static analysis only), basic logic gates, CMOS logic, Static and transient analysis of CMOS inverter, Switching power dissipation and delays. Realization of logic functions with static CMOS logic, Pass transistor logic, and transmission gate logic

Module 3: Dynamic logic Design and Storage Cells

Dynamic Logic Design-Pre charge- Evaluate logic, Domino Logic, NP domino logic.

Read Only Memory-4x4 MOS ROM Cell Arrays(OR,NOR,NAND)

Random Access Memory –SRAM-Six transistor CMOS SRAM cell, DRAM –Three transistor and One transistor Dynamic Memory Cell.

Module 4: Arithmetic circuits

Adders: Static adder, Carry-Bypass adder, Linear Carry- Select adder, Square- root carry- select adder. **Multipliers:** Array multiplier.

Module 5: Fabrication techniques and MOSFET physical Design**Material Preparation**

Purification and Crystal growth (CZ process), wafer preparation

Thermal Oxidation- Growth mechanisms, Dry and Wet oxidation.

Diffusion and ion implantation techniques.

Epitaxy : molecular beam epitaxy.

Lithography- Photo lithographic sequence, Electron Beam Lithography, Etching and metal deposition techniques.

MOSFET Fabrication techniques

Twin-Tub fabrication sequence, Fabrication process flow.

Layout Design and Design rules, Stick Diagram and Design rules-micron rules and Lambda rules. (definitions only).layout of CMOS Inverter, two input NAND and NOR gates.

Text Books:

1. Sung –Mo Kang & Yusuf Leblebici, CMOS Digital Integrated Circuits- Analysis & Design, McGraw-Hill, Third Ed., 2003
2. S.M. SZE, VLSI Technology, 2/e, Indian Edition, McGraw-Hill,2003
3. Wayne Wolf ,Modern VLSI design, Third Edition, Pearson Education,2002.

References:

1. Michael John Sebastian Smith, Application Specific Integrated Circuits, Pearson Education,2001.
2. Neil H.E. Weste, Kamran Eshraghian, Principles of CMOS VLSI Design- A Systems Perspective, Second Edition. Pearson Publication, 2005.
3. Jan M. Rabaey, Digital Integrated Circuits- A Design Perspective, Prentice Hall, Second Edition, 2005.
4. Razavi - Design of Analog CMOS Integrated Circuits,1e, McGraw Hill Education India Education, New Delhi, 2003.
- 5.

Course Contents and Lecture Schedule.

No	Topic	No. of Lectures
Module 1: VLSI Design Methodologies. (11 Hrs)		
1.1	Introduction: Moore slaw .ASIC design, Full custom ASICs, Standard cell based ASICs, Gate array based ASICs,	3
1.2	SoCs, FPGA devices	2
1.3	ASIC and FPGA Design flows Top-Down and Bottom-Up design methodologies.	3
1.4	Logical and Physical design. Speed power and area considerations in VLSI design	3
Module 2:Static CMOS Logic Design (9 Hrs)		
2.1	MOSFET Logic Design - NMOS logic (Static analysis of Basic gates only)	3
2.2	CMOS logic, Static and transient analysis of CMOS inverter Switching power dissipation and delays	3
2.3	Realization logic functions in static CMOS logic, Pass transistor logic, and transmission gate logic (Static analysis only)	3
Module 3: Dynamic logic Design and Storage Cells (8 Hrs)		
3.1	Dynamic Logic Design-Pre charge- Evaluate logic, Domino Logic, NP domino logic.	3

3.2	Read Only Memory -4x4 MOS ROM Cell Arrays(OR,NOR,NAND)	2
3.3	Random Access Memory –SRAM-Six transistor CMOS SRAM cell, DRAM –Three transistor and One transistor Dynamic Memory Cell.	3
Module 4: Arithmetic circuits (5 Hrs)		
4.1	Adders - Static adder, Carry-Bypass adder, Linear Carry- Select adder, Square- root carry- select adder.	3
4.2	Multipliers -Array multiplier.	2
Module 5: MOSFET physical Design and Fabrication techniques (13 Hrs)		
5.1	Material Preparation (qualitative analysis only) Purification and Crystal growth (CZ process), wafer preparation.	2
5.2	Thermal Oxidation - Growth mechanisms, Dry and Wet oxidation. Diffusion and ion implantation techniques.	3
5.3	Epitaxy : Molecular beam epitaxy. Lithography - Photo lithographic sequence, Electron Beam Lithography, Etching and metal deposition techniques	3
5.4	MOSFET Fabrication techniques (<i>qualitative analysis only</i>) Twin-Tub fabrication sequence, Fabrication process flow.	2
5.5	Layout Design and Design rules , Stick Diagram and Design rules- micron rules and Lambda rules. Layout of CMOS Inverter, two input NAND and NOR gates,	3

Model Question Paper**A P J Abdul Kalam Technological University**

Sixth Semester B Tech Degree Examination

Branch: Electronics and Communication Course:

ECT 304 VLSI CIRCUIT DESIGN

Time: 3 Hrs Max.

Marks: 100

PART A*(Answer All Questions)*

- 1 What is Moore's law in VLSI design? (3)
- 2 Differentiate between ASIC and FPGA. (3)
- 3 Switching threshold voltage equation of CMOS inverter and explain each parameter (3)
- 4 List the advantage of CMOS logic. (3)
- 5 List the advantages of dynamic logic over static logic circuits. (3)
- 6 Differentiate between volatile and non volatile memories. (3)
- 7 Explain propagate delay and generate signals. (3)
- 8 What are the different types of power dissipation in a CMOS inverter? (3)
- 9 List the advantages of SiO₂ (3)
- 10 Define lambda rules and micron rules. (3)

PART B*(Answer one question from each module. Each question carries 14 mark.)*

- 11(A) What is FPGA? What are its applications? With block diagram explain its internal architecture? (6)
 - 11(B) Explain ASIC design flow. (8)
- OR
- 12(A) Compare different ASIC design methodologies. (8)
 - 12(A) List the advantages of SOC (6)
- 13(A) Derive expression for the switching threshold of a CMOS inverter. (7)
 - 13(B) What is meant by pass transistor logic? What are the differences in transmission characteristics of N MOS and P MOS transistors? (7)
- OR
- 14(A) What are the different types of power dissipation in a CMOS inverter? Derive expression for the total power dissipation. (8)
 - 14(B) Why PMOS transistor can pass only strong ones and NMOS can pass strong zeros. (6)

- 15(A) Draw the circuit diagram and explain the principle of operation of a CMOS based static RAM cell. Explain the read and write operations. What are the constraints on the sizes of transistors? (7)
- 15(B) Draw the circuit diagram and explain the principle of operation of a one transistor dynamic RAM cell. Explain the read, write and refresh operations (7)
- OR
- 16(A) Explain the read and write operation of a three-transistor DRAM cell (7)
- 16(B) Explain the read and write operation of a six transistor CMOS SRAM cell. (7)
- OR
- 17(A) With diagram illustrate the principle of operation of an array multiplier. Show the critical path. Estimate the delay of the multiplier. (8)
- 17(B) With block diagram illustrate the principle of operation of a square root carry select adder. Estimate the delay of an n bit adder (6)
- OR
- 18(A) Draw circuit diagram of a full adder with not more than 28 transistors in standard CMOS logic (8)
- 18(B) Explain the working a 16-bit carry-by pass adder and write down the expression for worst-case delay. (6)
- 19(A) Illustrate with diagram the principle of crystal growth by Czochralzki method. (7)
- 19(B) What is photolithography? With diagram illustrate the steps involved in photolithography process. (7)
- OR
- 20(A) Explain the principle of molecular beam epitaxy, with schematic diagram of an MBE system. What are its advantages and disadvantages? (8)
- 20(B) With schematic diagram and chemical reactions involved, illustrate wet and dry oxidation processes (6)

MODEL ASSIGNMENT QUESTIONS**Module 1**

1. How to choose between FPGA and ASIC ?
2. Describe ASIC in terms of Size, power and performance, IP protection and competitive Edge
3. Compare Gate-array design and Full-custom design?
4. What are the differences between CPLDs and CLBs
5. List some of the commonly used FPGA development board ?
6. Discuss the architecture of any one of the leading FPGA in industry ?

Module 2

1. Power and interconnect delay analysis of CMOS inverter?
2. Implement XOR function using pass transistor logic?
3. Derive V_{IL} , V_{IH} , V_{OH} , and V_{OL} of depletion load inverter?
4. Design 8:1 MUX using transmission gate logic?
5. What are the advantages of NMOS over CMOS ?

Module 3

1. Explain the working of sense amplifiers in memory structures?
2. Design a voltage comparator in precharge-evaluate logic .
3. Discuss the cascading problem of P-E logic
4. Discuss the architecture of FLASH EPROM
5. Explain the working of FGMOS

Module 4

1. With diagram illustrate the principle of operation of an array multiplier. Show the critical path. Estimate the delay of the multiplier
2. Implement a 3x3 array multiplier?

Module 5

1. What is photolithography? With diagram illustrate the steps involved in photolithography process?
2. What is Deal Grove model of oxidation? What are linear and parabolic rate coefficients with reference to oxidation process?
3. Illustrate with diagram the principle of crystal growth by Czochralzki method
4. Explain DEAL-GROVE model of oxidation?
5. What are the requirements of a "clean-room" in VLSI fabrication

ECT306	INFORMATION THEORY AND CODING	CATEGORY	L	T	P	CREDIT
		PCC	3	1	0	4

Preamble: This course aims to lay down the foundation of information theory introducing both source coding and channel coding. It also aims to expose students to algebraic and probabilistic error-control codes that are used for reliable transmission.

Prerequisite: MAT 201 Linear Algebra and Calculus, MAT 204 Probability, Random Process and Numerical Methods, ECT 204 Signals and Systems.

Course Outcomes: After the completion of the course the student will be able to

CO 1	Explain measures of information – entropy, conditional entropy, mutual information
CO 2	Apply Shannon’s source coding theorem for data compression.
CO 3	Apply the concept of channel capacity for characterize limits of error-free transmission.
CO 4	Apply linear block codes for error detection and correction
CO 5	Apply algebraic codes with reduced structural complexity for error correction
CO 6	Understand encoding and decoding of convolutional and LDPC codes

Mapping of course outcomes with program outcomes

	PO 1	PO 2	PO 3	PO 4	PO 5	PO 6	PO 7	PO 8	PO 9	PO 10	PO 11	PO 12
CO 1	3	3										
CO 2	3	3	2	3	3							
CO 3	3	3	2	3	3	2						2
CO 4	3	3	2	3	3	2						2
CO 5	3	3	2	3	3	2						2
CO 6	3	3	2	3	3	2						2

Assessment Pattern

Bloom’s Category	Continuous Assessment Tests		End Semester Examination
	1	2	
Remember	10	10	20
Understand	30	30	60
Apply	10	10	20
Analyse			
Evaluate			
Create			

Mark distribution

Total Marks	CIE	ESE	ESE Duration
150	50	100	3 hours

Continuous Internal Evaluation Pattern:

Attendance	: 10 marks
Continuous Assessment Test (2 numbers)	: 25 marks
Assignment/Quiz/Course project	: 15 marks

End Semester Examination Pattern: There will be two parts; Part A and Part B. Part A contain 10 questions with 2 questions from each module, having 3 marks for each question. Students should answer all questions. Part B contains 2 questions from each module of which student should answer any one. Each question can have maximum 2 sub-divisions and carry 14 marks.

Course Level Assessment Questions**Course Outcome 1 (CO1): Entropy, Mutual Information**

1. Prove that entropy of a discrete random variable is upper bounded by logarithm of alphabet size.
2. Prove that $I(X:Y|Z)$ is always greater than or equal to 0.

Course Outcome 2 (CO2): Source Coding

1. State and prove Kraft's inequality for uniquely decodable codes.
2. Describe operational meaning of entropy in the light of Shannons's source coding theorem.

Course Outcome 3 (CO2): Channel Capacity

1. Derive the expression for capacity of binary symmetric channel.
2. Define differential entropy and derive its expression for a Gaussian distributed random variable with zero mean value and variance σ^2 .
3. Explain the inferences from Shannon Hartley theorem with the help of spectral efficiency versus SNR per bit graph.

Course Outcome 4 (CO4): Linear Block Codes

1. Construct a table for GF(23) based on the primitive polynomial, $p(x) = 1 + x + x^3$.
2. Find generator and parity check matrix in systematic format of the (6,3) linear block code for the given parity matrix.

$$P = \begin{bmatrix} 1 & 1 & 0 \\ 0 & 1 & 1 \\ 1 & 1 & 1 \\ 1 & 0 & 1 \end{bmatrix}$$

3. Explain standard array decoding of linear block codes.

Course Outcome 4 (CO4): Algebraic codes

1. Draw and explain the decoder circuit of (n, k) cyclic codes.
2. Give the properties of BCH codes.

Course Outcome 5 (CO5): Convolutional and LDPC Codes

1. Obtain the output codeword corresponding to the information sequence (1 1 0 1 1) for a convolutional encoder with rate $\frac{1}{2}$ and constraint length 4, for generator sequences, $g(1) = (1011)$ and $g(2) = (1111)$.
2. Explain the message-passing decoding algorithm for LDPC codes with respect to binary erasure channel.

SYLLABUS**Module 1 – Entropy, Sources and Source Coding**

Entropy, Properties of Entropy, Joint and Conditional Entropy, Mutual Information, Properties of Mutual Information.

Discrete memoryless sources, Source code, Average length of source code, Bounds on average length, Uniquely decodable and prefix-free source codes. Kraft Inequality (with proof), Huffman code. Shannon's source coding theorem (both achievability and converse) and operational meaning of entropy.

Module 2 – Channels and Channel Coding

Discrete memoryless channels. Capacity of discrete memoryless channels. Binary symmetric channels (BSC), Binary Erasure channels (BEC). Capacity of BSC and BEC. Channel code. Rate of channel code. Shannon's channel coding theorem (both achievability and converse without proof) and operational meaning of channel capacity.

Modeling of Additive White Gaussian channels. Continuous-input channels with average power constraint. Differential entropy. Differential Entropy of Gaussian random variable. Relation between differential entropy and entropy. Shannon-Hartley theorem (with proof – mathematical subtleties regarding power constraint may be overlooked).

Inferences from Shannon Hartley theorem – spectral efficiency versus SNR per bit, power-limited and bandwidth-limited regions, Shannon limit, Ultimate Shannon limit.

Module 3 – Introduction to Linear Block Codes

Overview of Groups, Rings, Finite Fields, Construction of Finite Fields from Polynomial rings, Vector spaces.

Block codes and parameters. Error detecting and correcting capability. Linear block codes. Two simple examples -- Repetition code and single parity-check code. Generator and parity-check matrix. Systematic form.

Maximum likelihood decoding of linear block codes. Bounded distance decoding. Syndrome. Standard array decoding.

Module 4 – A Few Important Classes of Algebraic codes

Cyclic codes. Polynomial and matrix description. Interrelation between polynomial and matrix view point. Systematic encoding. Decoding of cyclic codes.

(Only description, no decoding algorithms) Hamming Codes, BCH codes, Reed-Solomon Codes.

Module 5 – Convolutional and LDPC Codes

Convolutional Codes. State diagram. Trellis diagram. Maximum likelihood decoding. Viterbi algorithm.

Low-density parity check (LDPC) codes. Tanner graph representation. Message-passing decoding for transmission over binary erasure channel.

Text Books and References

1. “Elements of Information Theory”, Joy A Thomas, Thomas M Cover, Wiley-Interscience.
2. “Information Theory, Inference and Learning Algorithms”, David JC McKay, Cambridge University Press
3. “Principles of digital communication”, RG Gallager, Cambridge University Press
4. “Digital Communication Systems”, Simon Haykin, Wiley.
5. “Introduction to Coding Theory”, Ron M Roth, Cambridge University Press
6. Shu Lin & Daniel J. Costello, Jr., Error Control Coding : Fundamentals and Applications, 2nd Edition.
7. Modern Coding Theory, Rüdiger Urbanke and TJ Richardson, Cambridge University Press.

Course Contents and Lecture Schedule

No	Topic	No. of Lectures
1	Entropy, Sources and Source Coding	
1.1	Entropy, Properties of Entropy, Joint and Conditional Entropy	2
1.2	Mutual Information, Properties of Mutual Information	2
1.3	Discrete memoryless sources, Source code, Average length of source code, Bounds on average length	2
1.4	Uniquely decodable and prefix-free source codes. Kraft Inequality (with proof)	2
1.5	Huffman code. Shannon’s source coding theorem and operational meaning of entropy	2
2	Channels and Channel Coding	
2.1	Discrete memoryless channels. Capacity of discrete memoryless channels	1
2.2	Binary symmetric channels (BSC), Binary Erasure channels (BEC). Capacity of BSC and BEC.	2

2.3	Channel code. Rate of channel code. Shannon's channel coding theorem (without proof) and operational meaning of channel capacity.	2
2.4	Modeling of Additive White Gaussian channels. Continuous-input channels with average power constraint.	1
2.5	Differential entropy. Differential Entropy of Gaussian random variable. Relation between differential entropy and entropy	2
2.6	Shannon-Hartley theorem and its proof	1
2.7	Inferences from Shannon Hartley theorem – spectral efficiency versus SNR, power-limited and bandwidth-limited regions, Shannon limit, Ultimate Shannon limit.	2
3	Introduction to Linear Block Codes	
3.1	Overview of Groups, Rings, Finite Fields, Construction of Finite Fields from Polynomial rings, Vector spaces.	5
3.2	Block codes and parameters. Error detecting and correcting capability	1
3.3	Linear block codes. Generator and parity-check matrix. Systematic form. Two simple examples -- Repetition code and single parity-check code. General examples.	2
3.5	Maximum likelihood decoding of linear block codes. Bounded distance decoding. Syndrome. Standard array decoding.	3
4	A Few Important Classes of Algebraic codes	
4.1	Cyclic codes. Polynomial and matrix description. Interrelation between polynomial and matrix view point. Systematic encoding. Decoding of cyclic codes.	4
4.2	Hamming Codes,	1
4.3	BCH codes, Reed-Solomon Codes.	2
5	Convolutional and LDPC Codes	
5.1	Convolutional Codes.	1
5.2	State diagram. Trellis diagram.	2
5.3	Maximum likelihood decoding. Viterbi algorithm	
5.4	Low-density parity check (LDPC) codes. Tanner graph representation Message-passing decoding for transmission over binary erasure channel.	2

ECT 306 Information Theory and Coding

Simulation Assignments

The following simulation assignments can be done with Python/MATLAB/SCILAB/LabVIEW

1. **Source Coding - Huffman Code**
 1. Generate Huffman code for the source with symbol probabilities $\{1/2, 1/3, 1/6\}$.
 2. Find the entropy, average codeword length and efficiency of the code.
 3. Create the second order extended source by taking probabilities of 9 symbols in the extended source as the product of every possible combinations of two symbols from the original source.
 4. Generate Huffman code for the extended source symbols and find the entropy, average codeword length and efficiency of the code.
 5. Compare the two efficiencies and appreciate the Shannon's source coding theorem.

2. **Binary Symmetric Channel**
 1. Create a 2×2 matrix, $P(Y/X)$ for binary symmetric channel with channel transition probability, $p < 0.5$.
 2. Let the input symbol probabilities corresponding to symbol 0 and 1 be α and $(1 - \alpha)$ respectively. For different values of α ranging from 0 to 1, find the joint probability matrix, $P(X,Y)$ and output probability, $P(Y)$
 3. Find mutual information, $I(X; Y) = H(Y) - H(Y/X)$ for each value of α . Plot the $I(X; Y)$ versus α graph and observe the channel capacity.

3. **Linear Block Code (LBC)**
 1. Create the $k \times n$ generator matrix, G of (n, k) LBC.
 2. Generate all possible codewords by multiplying the message vector of length, k with G .
 3. Calculate the Hamming weight of all codewords and obtain the minimum distance, d_{min} of the code.
 4. Find its error correcting and detecting capability.

5. **Cyclic Code – Encoder & Decoder**
 1. Realize the encoder circuit for $(7, 4)$ cyclic code in Fig. 4.2 in page 96 in *Error Control Coding: Fundamentals and Applications* by Shu Lin & Daniel J. Costello. Jr.

2. Create a random binary vector of length 4 as input message vector and generate the codeword.
 3. Create binary vector of length 7 with Hamming weight 1 as error vector and add it to the encoder output to generate the receiver output.
 4. Realize the decoder circuit for (7, 4) cyclic code in Fig. 4.9 in page 107 in *Error Control Coding: Fundamentals and Applications* by Shu Lin & Daniel J. Costello. Jr.
 5. Observe the encoder and decoder outputs for different message vectors and error vectors and find the error correcting capability of the code.
6. **Convolutional Code**
1. Implement (2,1,3) convolutional encoder in Fig. 10.1 in page 288 in *Error Control Coding: Fundamentals and Applications* by Shu Lin & Daniel J. Costello. Jr.
 2. Give a message vector, u of arbitrary length as input to the encoder.
 3. Generate the output code sequence.

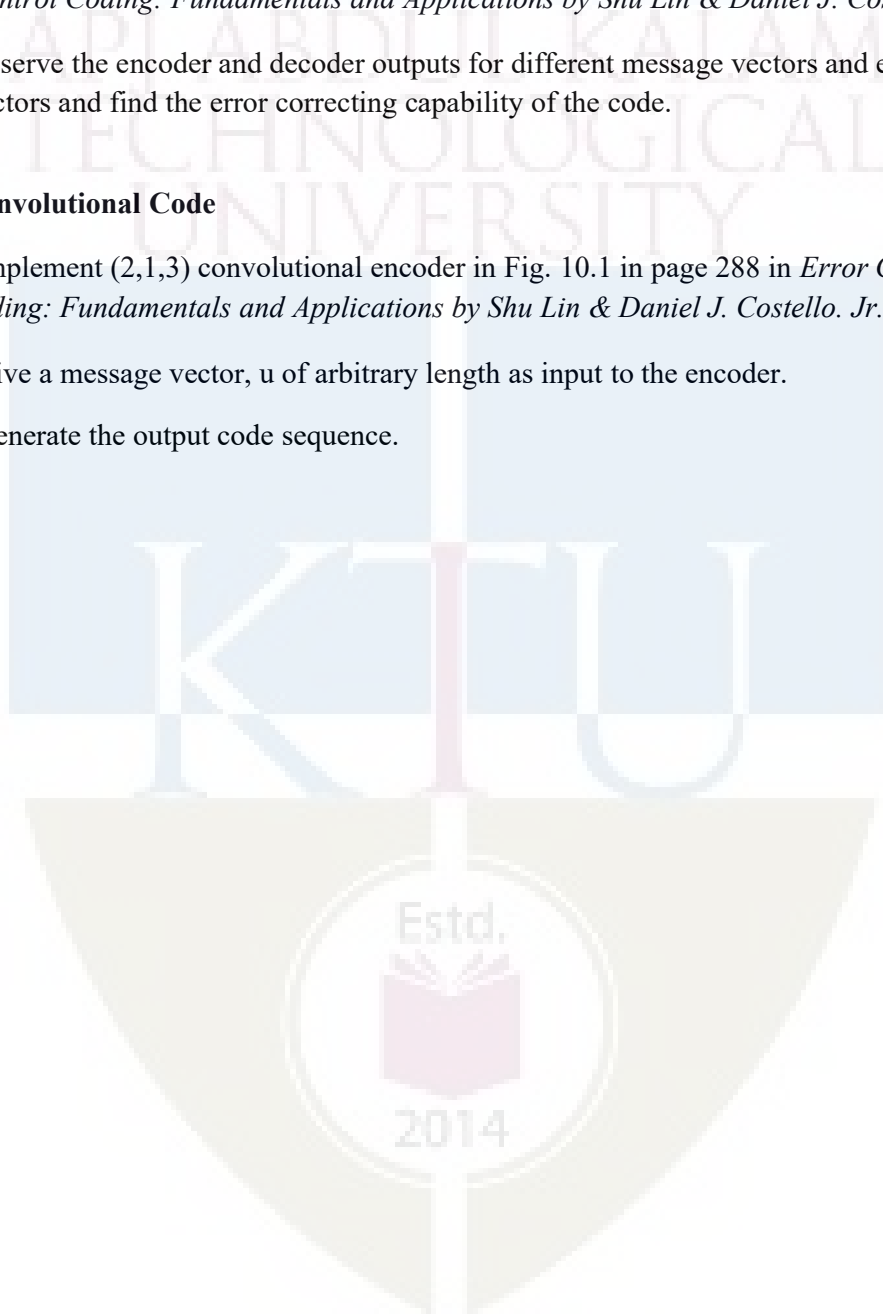

APJ ABDUL KALAM TECHNOLOGICAL UNIVERSITY
ECT 306 INFORMATION THEORY AND CODING

Time: 3 hours

Max. Marks:100

PART A

Answer **all** questions. Each question carries **3 marks**.

1. A source emits one of four symbols, s_0, s_1, s_2, s_3 with probabilities $1/3, 1/6, 1/4$ and $1/4$ respectively. The successive symbols emitted by the source are statistically independent. Calculate the entropy of the source.
2. Identify the instantaneous codes from the code sets listed below.

Symbol	Code I	Code II	Code III	Code IV
s_0	0	0	0	00
s_1	10	01	01	01
s_2	110	001	011	10
s_3	1110	0010	110	110
s_4	1111	0011	111	111

3. State Shannon's channel coding theorem. What is its significance in digital communication system?
4. An analog signal band limited to 'B' Hz is sampled at Nyquist rate. The samples are quantized into 4 levels. The quantization levels are assumed to be independent and occur with probabilities: $p_1 = p_4 = 1/8, p_2 = p_3 = 3/8$. Find the information rate of the source assuming $B = 100\text{Hz}$.
5. List the properties of group. Give an example.
6. Show that $C = \{0000, 1100, 0011, 1111\}$ is a linear code. What is its minimum distance?
7. Explain generation of systematic cyclic code using polynomial description.
8. List the features of Reed Solomon code.
9. Draw a (3,2,1) convolutional encoder with generator sequences, $g_1^{(1)} = (11), g_1^{(2)} = (01), g_1^{(3)} = (11)$ and $g_2^{(1)} = (01), g_2^{(2)} = (10), g_2^{(3)} = (10)$.
10. Draw the Tanner graph of rate $1/3$ LDPC code for the given parity check matrix.

$$H = \begin{bmatrix} 1 & 1 & 1 & 0 & 0 & 0 \\ 1 & 0 & 0 & 1 & 1 & 0 \\ 0 & 1 & 0 & 1 & 0 & 1 \\ 0 & 0 & 1 & 0 & 1 & 1 \end{bmatrix}$$

PART B

Answer **any one** question from each module. Each question carries 14 marks.

MODULE I

11 (a) The joint probability of a pair of random variables is given below. Determine $H(X, Y)$, $H(X/Y)$, $H(Y/X)$ and $I(X, Y)$. Verify the relationship between joint, conditional and marginal entropies.

$$P(X, Y) = \begin{bmatrix} 1/3 & 1/3 \\ 0 & 1/3 \end{bmatrix}$$

(10 marks)

11 (b) Explain uniquely decodable and prefix-free property of source code. (4 marks)

12 (a) Find the binary Huffman code for the source with probabilities $\{1/3, 1/5, 1/5, 2/15, 2/15\}$. Also find the efficiency of the code. (9 marks)

12 (b) Prove that $H(Y) \geq H(Y/X)$. (5 marks)

MODULE II

13 (a) A voice grade channel of the telephone network has a bandwidth of 3.4 KHz. Calculate channel capacity of the telephone channel for signal to noise ratio of 30 dB. Also determine the minimum SNR required to support information transmission through the telephone channel at the rate of 4800 bits/sec.

(7 marks)

13 (b) Derive the expression for channel capacity for binary erasure channel. (7 marks)

14 (a) A binary channel has the following noise characteristic.

$$P(Y/X) = \begin{bmatrix} 2/3 & 1/3 \\ 1/3 & 2/3 \end{bmatrix}$$

If the input symbols are transmitted with probabilities $3/4$ and $1/4$ respectively, find $I(X; Y)$. Also compute channel capacity and what are the input symbol probabilities that correspond to the channel capacity. (9 marks)

14 (b) State Shannon Hartley theorem and explain the significance of Shannon limit. (6 marks)

MODULE III

15 (a) The parity check matrix of (7,4) linear block code is given as

$$H = \begin{bmatrix} 1 & 00 & 1 & 01 & 1 \\ 0 & 10 & 1 & 11 & 0 \\ 0 & 01 & 0 & 11 & 1 \end{bmatrix}$$

Compute the minimum distance of the code and find its error detection and correcting capability. Suppose that the received codeword, $r = (1001111)$. Determine whether the received codeword is in error? If so, form the decoding table and obtain the correct codeword. (9 marks)

16 (b) List the properties of vector space. Define subspace. (5 marks)

17 (a) The parity bits of a (8, 4) linear systematic block code are generated by

$$c_5 = d_1 + d_2 + d_4$$

$$c_6 = d_1 + d_2 + d_3$$

$$c_7 = d_1 + d_3 + d_4$$

$$c_8 = d_2 + d_3 + d_4$$

(+ sign denotes modulo-2 addition)

where d_1, d_2, d_3 and d_4 are message bits and c_5, c_6, c_7 and c_8 are parity bits. Find generator matrix G and parity check matrix H for this code. Draw the encoder circuit (7 marks)

17 (b) Explain the construction of finite field from polynomial ring with the help of an ex-ample.

(7 marks)

MODULE IV

18 (a) Consider a (7, 4) cyclic code with generator polynomial, $g(x) = 1 + x + x^3$. Express the generator matrix and parity-check matrix in systematic and non-systematic form

(8 Marks)

18 (b) Find the generator polynomial for single, double and triple error correcting BCH code of block length, $n = 15$.

(6 marks)

19 (a) Draw syndrome circuit for a (7,4) cyclic code generated by $g(x)=1+x+x^3$. If the received vector r is [0010110] what is the syndrome of r ? Explain the circuit with a table showing the contents of the syndrome register.

(8 Marks)

19 (b) What are the features of Hamming code? Find the parity check matrix for (15, 11) Hamming code.

(6 marks)

MODULE V

20 (a) Draw the state diagram of a convolution encoder with rate $1/3$ and constraint length

3 for generator sequences $g^{(1)} = (1\ 0\ 0)$, $g^{(2)} = (1\ 0\ 1)$, $g^{(3)} = (1\ 1\ 1)$.

(7 marks)

20 (b) Explain message passing decoding algorithm for LDPC codes with the help of an example.

(7 marks)

21 For a (2,1,2) convolutional encoder with generator sequences $g^{(1)} = (1\ 1\ 1)$ and $g^{(2)} = (1\ 0\ 1)$. Draw Trellis and perform Viterbi decoding on this trellis for the received sequence {01, 10, 10, 11, 01, 01, 11} and obtain the estimate of the transmitted sequence.

(14 marks)

Assessment Pattern

Bloom's Category	End Semester Examination
Remember	10
Understand	20
Apply	20
Analyse	
Evaluate	
Create	

Mark distribution

Total Marks	CIE	ESE	ESE Duration
50	0	50	1 hour

End Semester Examination Pattern: Objective Questions with multiple choice (Four). Question paper include Fifty Questions of One mark each covering the five identified courses.

Syllabus
Full Syllabus of all five selected courses

Course Contents and Lecture Schedule

No	Topic	No. of Lectures
1	Analog Circuits	
1.1	Mock Test on Module 1 and Module 2	1
1.2	Mock Test on Module 3, Module 4 and Module 5	1
1.3	Feedback and Remedial	1
2	Logic Circuit design	
2.1	Mock Test on Module 1, Module 2 and Module 3	1
2.2	Mock Test on Module 4 and Module 5	1
2.3	Feedback and Remedial	1
3	Linear IC	
3.1	Mock Test on Module 1 and Module 2	1
3.2	Mock Test on Module 3, Module 4 and Module 5	1
3.3	Feedback and Remedial	1
4	Digital Signal Processing	
4.1	Mock Test on Module 1, Module 2 and Module 3	1
4.2	Mock Test on Module 4 and Module 5	1
4.3	Mock Test on Module 1, Module 2 and Module 3	1
5	Analog and Digital Communication	
5.1	Mock Test on Module 1, Module 2 and Module 3	1
5.2	Mock Test on Module 4 and Module 5	1
5.3	Feedback and Remedial	1

ECL332	COMMUNICATION LAB	CATEGORY	L	T	P	CREDIT
		PCC	0	0	3	2

Preamble:

- The experiments are categorized into three parts Part A, Part B and Part C.
- The experiments in Part A involves design and setting up of prototype circuits on breadboard or trainer kits.
- The experiments in Part B are software simulations and can be done using GNU Octave or Python. Other softwares such as MATLAB/ SCILAB/ LabVIEW can also be used.
- The experiments in Part C are emulations using SDR (software-designed-radio) dongle connected to laptops. A control software has to be installed on the laptops. A combination of open-source GNU Radio software, RTL-SDR (for reception) and HackRF / LimeSDR (for transmission) can be used to conduct these experiments. Other platforms such as LabView with NI-USRP or Simulink with RTL-SDR can also be used.

Prerequisites:

- ECT 305 Analog and Digital Communication
- ECT 303 Digital Signal Processing

Course Outcomes :The student will be able to

CO 1	Setup simple prototype circuits for waveform coding and digital modulation techniques working in a team.
CO 2	Simulate the error performance of a digital communication system using standard binary and M -ary modulation schemes.
CO 3	Develop hands-on skills to emulate a communication system with software-designed-radio working in a team.

Mapping of Course Outcomes with Program Outcomes

	PO1	PO2	PO3	PO4	PO5	PO6	PO7	PO8	PO9	PO10	PO11	PO12
CO1	3	3	3	2	3	0	0	0	3	2	0	1
CO2	3	3	3	2	3	0	0	0	0	0	0	1
CO3	3	3	3	3	3	0	0	0	3	2	0	3

Assessment Pattern Mark**Distribution;**

Total Mark	CIE	ESE
150	75	75

Continuous Internal Evaluation Pattern:

Attribute	Mark
Attendance	15
Continuous assessment	30
Internal Test (Immediately before the second series test)	30

End Semester Examination Pattern: The following guidelines should be followed regarding award of marks.

Attribute	Mark
Preliminary work	15
Implementing the work/Conducting the experiment	10
Performance, result and inference (usage of equipments and trouble shooting)	25
Viva voce	20
Record	5

General instructions: End-semester practical examination is to be conducted immediately after the second series test covering entire syllabus given below. Evaluation is to be conducted under the equal responsibility of both the internal and external examiners. The number of candidates evaluated per day should not exceed 20. Students shall be allowed for the examination only on submitting the duly certified record. The external examiner shall endorse the record.

Experiments**Part A**

Any two experiments are mandatory. The students shall design and setup simple prototype circuits with the help of available ICs. They can observe Waveforms produced by these circuits for standard ideal inputs.

1. FM generation and demodulation using PLL
2. Generation and Detection of PCM signals

3. Generation and Detection of Delta modulated signals
4. Generation and Detection of BPSK
5. Generation and Detection of 16-QPSK

Part B

All experiments are mandatory. The students shall write scripts to simulate components of communication systems. They shall plot various graphs that help to appreciate and compare performance.

1. Performance of Waveform Coding Using PCM

1. Generate a sinusoidal waveform with a DC offset so that it takes only positive amplitude value.
2. Sample and quantize the signal using an uniform quantizer with number of representation levels L . Vary L . Represent each value using decimal to binary encoder.
3. Compute the signal-to-noise ratio in dB.
4. Plot the SNR versus number of bits per symbol. Observe that the SNR increases linearly.

2. Pulse Shaping and Matched Filtering

1. Generate a string of message bits.
2. Use root raised cosine pulse $p(t)$ as the shaping pulse, and generate the corresponding baseband signal with a fixed bit duration T_b . You may use roll-off factor as $\alpha = 0.4$.
3. Simulate transmission of baseband signal via an AWGN channel
4. Apply matched filter with frequency response $P_r(f) = P^*(f)$ to the received signal.
5. Sample the signal at mT_b and compare it against the message sequence.

3. Eye Diagram

1. Generate a string of message bits.
2. Use raised cosine pulse $p(t)$ as the shaping pulse, and generate the corresponding baseband signal with a fixed bit duration T_b . You may use roll-off factor as $\alpha = 0.4$.
3. Use various roll off factors and plot the eye diagram in each case for the received signal. Make a comparison study among them.

4. Error Performance of BPSK

1. Generate a string of message bits.
2. Encode using BPSK with energy per bit E_b and represent it using points in a signal-space.
3. Simulate transmission of the BPSK modulated signal via an AWGN channel with variance $N_0/2$.
4. Detect using an ML decoder and plot the probability of error as a function of SNR per bit E_b/N_0 .

5. Error Performance of QPSK

1. Generate a string of message bits.
2. Encode using QPSK with energy per symbol E_s and represent it using points in a signal-space.
3. Simulate transmission of the QPSK modulated signal via an AWGN channel with variance $N_0/2$ in both I -channel and Q -channel.
4. Detect using an ML decoder and plot the probability of error as a function of SNR per bit E_b/N_0 where $E_s = 2E_b$.

Part C

Any two experiments are mandatory. The students shall emulate communication systems with the help of software-defined-radio hardware and necessary control software. Use available blocks in GNU Radio to implement all the signal processing. These experiments will help students to appreciate better how theoretical concepts are translated into practice.

1. Familiarization with Software Defined Radio (Hardware and Control Software)

1. Familiarize with an SDR hardware for reception and transmission of RF signal.
2. Familiarize how it can be interfaced with computer.
3. Familiarize with GNU Radio (or similar software's like Simulink/ Lab-View) that can be used to process the signals received through the SDR hardware.
4. Familiarize available blocks in GNU Radio. Study how signals can be generated and spectrum (or power spectral density) of signals can be analyzed. Study how filtering can be performed.

2. FM Reception

1. Receive digitized FM signal (for the clearest channel in the lab) using the SDR board.
2. Set up an LPF and FM receiver using GNU Radio.
3. Use appropriate sink in GNU Radio to display the spectrum of signal.
4. Resample the voice to make it suitable for playing on computer speaker.

3. FM Transmission

1. Use a wave file source.
2. Set up an FM transmitter using GNU Radio.
3. Resample the voice source and transmit using the SDR.

Schedule of Experiments Every experiment should be completed in three hours.

Text books and References

1. Carl Laufer, "The Hobbyist's Guide to the RTL-SDR: Really Cheap Software Defined Radio"
2. Neel Pandeya, "Implementation of a Simple FM Receiver in GNU Radio," <https://kb.ettus.com/>
3. WH Tranter, KS Shanmugan, TS Rappaport, KL Kosbar, "Principles of Communication Systems Simulation with Wireless Applications", Prentice Hall
4. Michael Ossmann, "Software Defined Radio with HackRF," YouTube Tutorial
5. Mathuranathan Viswanathan, "Digital Modulations using Python"

ECD334	MINIPROJECT	CATEGORY	L	T	P	CREDIT
		PWS	0	0	3	2

Preamble: The course aims

- To estimate the ability of the students in transforming the theoretical knowledge studied in to a working model of an electronic system
- For enabling the students to gain experience in organisation and implementation of small projects.
- Design and development of Small electronic project based on hardware or a combination of hardware and software for electronics systems.

Course Plan

In this course, each group consisting of three/four members is expected to design and develop a moderately complex electronic system with practical applications, this should be a working model. The basic concept of product design may be taken into consideration.

Students should identify a topic of interest in consultation with Faculty/Advisor. Review the literature and gather information pertaining to the chosen topic. State the objectives and develop a methodology to achieve the objectives. Carryout the design/fabrication or develop codes/programs to achieve the objectives. Demonstrate the novelty of the project through the results and outputs. The progress of the mini project is evaluated based on a minimum of two reviews.

The review committee may be constituted by the Head of the Department. A project report is required at the end of the semester. The product has to be demonstrated for its full design specifications. Innovative design concepts, reliability considerations, aesthetics/ergonomic aspects taken care of in the project shall be given due weight.

Course Outcomes

CO1	Be able to practice acquired knowledge within the selected area of technology for project development.
CO2	Identify, discuss and justify the technical aspects and design aspects of the project with a systematic approach.
CO3	Reproduce, improve and refine technical aspects for engineering projects.
CO4	Work as a team in development of technical projects.
CO5	Communicate and report effectively project related activities and findings.

Mapping of course outcomes with program outcomes

	PO 1	PO 2	PO 3	PO 4	PO 5	PO 6	PO 7	PO 8	PO 9	PO 10	PO 11	PO 12
CO 1	3	3	3	2		3						2
CO 2	3	3	3	2		3					3	2
CO 3	3	3	3	2		3					3	2
CO 4								3		3	3	2
CO 5								3	3	3		2

Evaluation

The internal evaluation will be made based on the product, the report and a viva- voce examination, conducted by a 3-member committee appointed by Head of the Department comprising HoD or a senior faculty member, Academic coordinator for that program, project guide/coordinator.

The Committee will be evaluating the level of completion and demonstration of functionality/specifications, presentation, oral examination, work knowledge and involvement.

Mark distribution

Total Marks	CIE	ESE	ESE Duration
150	75	75	1 hour

Split-up of CIE

Component	Marks
Attendance	10
Marks awarded based on guide's evaluation	15
Project Report	10
Evaluation by Committee	40

Split-up of ESE

Component	Marks
Level of completion	10
Demonstration of functionality	25
Project Report	10
Viva-voce	20
Presentation	10

APJ ABDUL KALAM
TECHNOLOGICAL
UNIVERSITY

SEMESTER VI

PROGRAM ELECTIVE I



ECT312	DIGITAL SYSTEM DESIGN	CATEGORY	L	T	P	CREDIT
		PEC	2	1	0	3

Preamble: This course aims to design hazard free synchronous and asynchronous sequential circuits and implement the same in the appropriate hardware device

Prerequisite: ECT203 Logic Circuit Design

Course Outcomes: After the completion of the course the student will be able to

CO 1 K4	Analyze clocked synchronous sequential circuits
CO 2 K4	Analyze asynchronous sequential circuits
CO 3 K3	Design hazard free circuits
CO 4 K3	Diagnose faults in digital circuits
CO 5 K2	Summarize the architecture of FPGA and CPLDs

Mapping of course outcomes with program outcomes

	PO 1	PO 2	PO 3	PO 4	PO 5	PO 6	PO 7	PO 8	PO 9	PO 10	PO 11	PO 12
CO1	3	3	3		2				2	2		3
CO2	3	3			2				2	2		3
CO3	3	3	3	3					2	2		3
CO4	3	2		1					2	2		3
CO5	2								2	2		3

Assessment Pattern

Bloom's Category		Continuous Tests	Assessment	End Semester Examination
		1	2	
Remember	K1	10	10	15
Understand	K2	10	20	30
Apply	K3	20	20	35
Analyse	K4	10		20
Evaluate				
Create				

Mark distribution

Total Marks	CIE	ESE	ESE Duration
150	50	100	3 hours

Continuous Internal Evaluation Pattern:

Attendance	: 10 marks
Continuous Assessment Test (2 numbers)	: 25 marks
Assignment/Quiz/Course project	: 15 marks

End Semester Examination Pattern: There will be two parts; Part A and Part B. Part A contain 10 questions with 2 questions from each module, having 3 marks for each question. Students should answer all questions. Part B contains 2 questions from each module of which student should answer any one. Each question can have maximum 2 sub-divisions and carry 14 marks.

Course Level Assessment Questions**Course Outcome 1 (CO1): Analyze clocked synchronous sequential circuits (K4)**

- Construct an ASM chart for a sequence recognizer to recognize the input sequence of pairs $x_1x_2 = 01, 01, 11, 00$. The output variable, 'z' is asserted when $x_1x_2 = 00$ if and only if the three preceding pairs of inputs are $x_1x_2 = 01, 01$ and 11 , in that order.
- Obtain a minimal state table for a clocked synchronous sequential network having a single input line 'x' in which the symbols 0 and 1 are applied and a single output line 'z'. An output of 1 is to be produced if and only if the 3 input symbols following two consecutive input 0's consist of at least one 1. An example of input/output sequences that satisfy the conditions of the network specifications is:

$x=0100010010010010000000011$
 $z=00000010000001000000000001$

- Analyse the following clocked synchronous sequential network. Derive the next state and output equations. Obtain the excitation table, transition table, state table and state diagram.

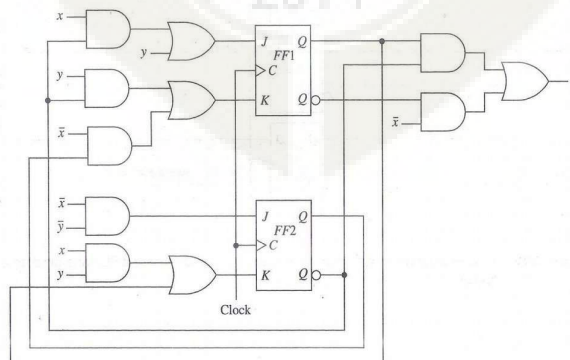

Course Outcome 2 (CO2): Analyze asynchronous sequential circuits (K4)

1. A reduced flow table for a fundamental-mode asynchronous sequential network is given below. Using the universal multiple-row state assignment, construct the corresponding expanded flow table and transition table. Assign outputs where necessary such that there is at most a single output change during the time the network is unstable. Assume that the inputs x_1 and x_2 never change simultaneously.

Present state	Next state				Output (z)			
	Input state (x_1x_2)				Input state (x_1x_2)			
	00	01	10	11	00	01	10	11
A	(A)	B	(A)	D	1	-	0	-
B	D	(B)	(B)	C	-	0	1	-
C	A	(C)	(C)	(C)	-	1	1	0
D	(D)	C	A	(D)	0	-	-	1

2. Analyze the asynchronous sequential network by forming the excitation/transition table, state table, flow table and flow diagram. The network operates in the fundamental mode with the restriction that only one input variable can change at a time.

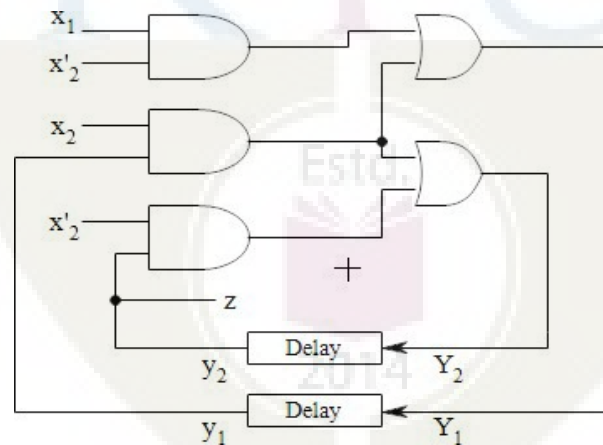

3. Describe races in ASN with example.

Course Outcome 3 (CO3): Design hazard free circuits (K3)

1. Differentiate between static and dynamic hazard.
2. Examine the possibility of hazards in the (i) OR-AND logic circuit whose Boolean function is given by $f = \sum(0,2,6,7)$ (ii) AND-OR logic circuit whose Boolean function is given by $f = \sum(3,4,5,7)$. Show how the hazard can be detected and eliminated in each circuit.

- Investigate the problem of clock skew in practical sequential circuits and suggest solutions with justification to minimize or eliminate it.

Course Outcome 4 (CO4): Diagnose faults in digital circuits (K3)

- Illustrate the fault table method used for effective test set generation for the circuit whose Boolean function is $z = \bar{x}_1x_2 + x_3$
- Find the test vectors of all SA0 and SA1 faults of the circuit whose Boolean function is $f = \bar{x}_1x_2 + x_1x_2x_3$ by the Kohavi algorithm.
- Write a note on BIST techniques.

Course Outcome 5 (CO5): Summarize the architecture of FPGA and CPLDs (K2)

- Draw and explain the architecture of Xilinx XC4000 configurable logic block.
- Draw and explain the architecture of Xilinx 9500 CPLD family.
- Explain the internal structure of XC4000 input/output block.

SYLLABUS

Module 1: Clocked Synchronous Networks

Analysis of clocked Synchronous Sequential Networks (CSSN), Modelling of CSSN – State assignment and reduction, Design of CSSN, ASM Chart and its realization

Module 2: Asynchronous Sequential Circuits

Analysis of Asynchronous Sequential Circuits (ASC), Flow table reduction- Races in ASC, State assignment problem and the transition table- Design of AS, Design of ALU

Module 3: Hazards

Hazards – static and dynamic hazards – essential, Design of Hazard free circuits – Data synchronizers, Mixed operating mode asynchronous circuits, Practical issues- clock skew and jitter, Synchronous and asynchronous inputs – switch bouncing

Module 4: Faults

Fault table method – path sensitization method – Boolean difference method, Kohavi algorithm, Automatic test pattern generation – Built in Self Test (BIST)

Module 5: CPLDs and FPGA

CPLDs and FPGAs - Xilinx XC 9500 CPLD family, functional block diagram– input output block architecture - switch matrix, FPGAs – Xilinx XC 4000 FPGA family – configurable logic block - input output block, Programmable interconnect

Text Books

1. Donald G Givone, Digital Principles & Design, Tata McGraw Hill, 2003
2. John F Wakerly, Digital Design, Pearson Education, Delhi 2002
3. John M Yarbrough, Digital Logic Applications and Design, Thomson Learning

Reference Books

1. Miron Abramovici, Melvin A. Breuer and Arthur D. Friedman, Digital Systems Testing and Testable Design, John Wiley & Sons Inc.
2. Morris Mano, M.D.Ciletti, Digital Design, 5th Edition, PHI.
3. N. N. Biswas, Logic Design Theory, PHI
4. Richard E. Haskell, Darrin M. Hanna , Introduction to Digital Design Using Digilent FPGA Boards, LBE Books- LLC
5. Samuel C. Lee, Digital Circuits and Logic Design, PHI
6. Z. Kohavi, Switching and Finite Automata Theory, 2nd ed., 2001, TMH

Course Contents and Lecture Schedule

No	Topic	No. of Lectures
1	Clocked Synchronous Networks	
1.1	Analysis of clocked Synchronous Sequential Networks(CSSN)	2
1.2	Modelling of CSSN – State assignment and reduction	2
1.3	Design of CSSN	2
1.4	ASM Chart and its realization	1
2	Asynchronous Sequential Circuits	
2.1	Analysis of Asynchronous Sequential Circuits (ASC)	2
2.2	Flow table reduction- Races in ASC	2
2.3	State assignment problem and the transition table- Design of AS	2
2.4	Design of ALU	2
3	Hazards	
3.1	Hazards – static and dynamic hazards – essential	1
3.2	Design of Hazard free circuits – Data synchronizers	1
3.3	Mixed operating mode asynchronous circuits	1
3.4	Practical issues- clock skew and jitter	1
3.5	Synchronous and asynchronous inputs – switch bouncing	2
4	Faults	
4.1	Fault table method – path sensitization method – Boolean difference method	2
4.2	Kohavi algorithm	2
4.3	Automatic test pattern generation – Built in Self Test(BIST)	3
5	CPLDs and FPGA	
5.1	CPLDs and FPGAs - Xilinx XC 9500 CPLD family, functional block diagram– input output block architecture - switch matrix	3
5.2	FPGAs – Xilinx XC 4000 FPGA family – configurable logic block - input output block, Programmable interconnect	3

Simulation Assignments:

At least one assignment should be design of digital circuits that can be used in day today life. This has to be done in a phased manner. The first phase involves the design in HDL (VHDL/ Verilog) and the second phase implementing the same in a hardware device. Some of the assignments are as listed below:

1. Design of vending machine
2. Design of ALU
3. Architecture of different FPGAs
4. Architecture of different CPLDs
5. Fault detection methods other than those mentioned in the syllabus
6. Metastability condition and methods to avoid it

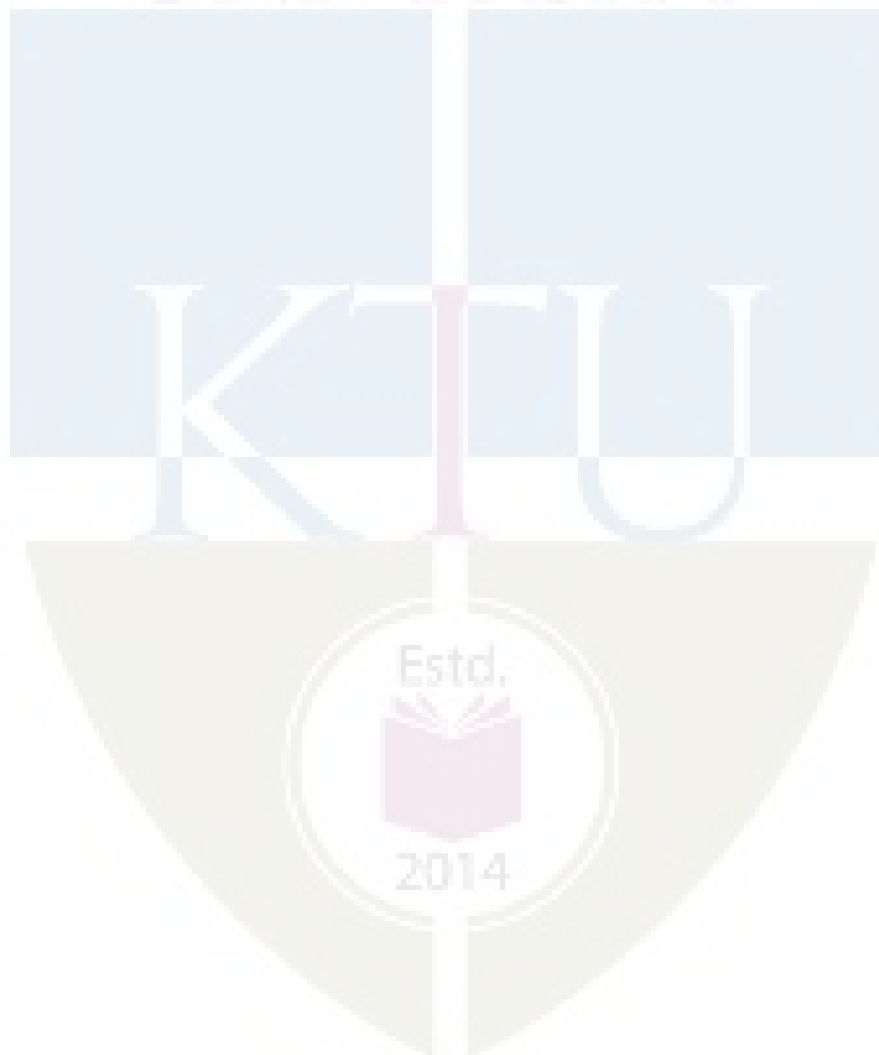

Model Question paper

APJ ABDUL KALAM TECHNOLOGICAL UNIVERSITY

SIXTH SEMESTER B.TECH DEGREE EXAMINATION, (Model Question Paper)

Course Code: ECT312

Course Name: DIGITAL SYSTEM DESIGN

Max. Marks: 100

Duration: 3 Hours

PART A

Answer ALL Questions. Each carries 3 marks.

- | | | |
|----|---|----|
| 1 | Differentiate Mealy and Moore models. | K1 |
| 2 | What are the elements in an ASM chart? | K1 |
| 3 | Describe one-hot assignment technique. | K2 |
| 4 | Define critical and non-critical races. | K1 |
| 5 | What is jitter? List the sources of clock jitter. | K2 |
| 6 | Differentiate positive skew and negative skew. | K2 |
| 7 | List the different types of faults in digital circuits. | K1 |
| 8 | Differentiate between fault and defect. | K2 |
| 9 | What are FPGA? What are the advantages ofFPGA? | K1 |
| 10 | Differentiate between FPGA and CPLD | K2 |

PART – B

Answer one question from each module; each question carries 14 marks.

Module - I

- 11 a Analyze the following sequential network. Derive the next state and output equations. Obtain its transition table and state table.

8

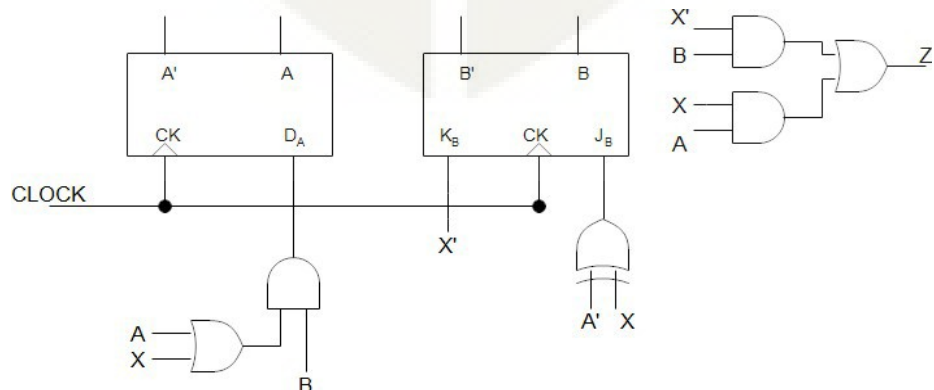

CO1
K4

- b. Construct an ASM chart for the following state diagram shown. Determine the model of CSSN that this system conforms to with proper justification.

6

CO1
K3

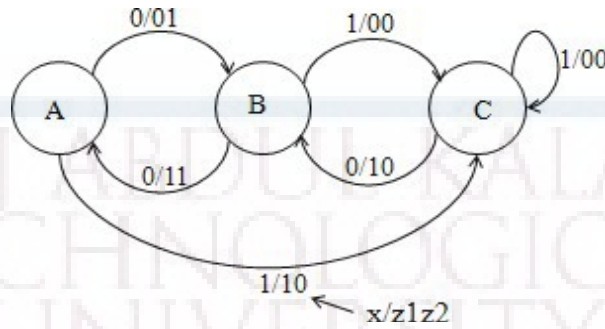

OR

- 12 For the clocked synchronous sequential network, construct the excitation table, transition table, state table and state diagram.

8

CO1
K4

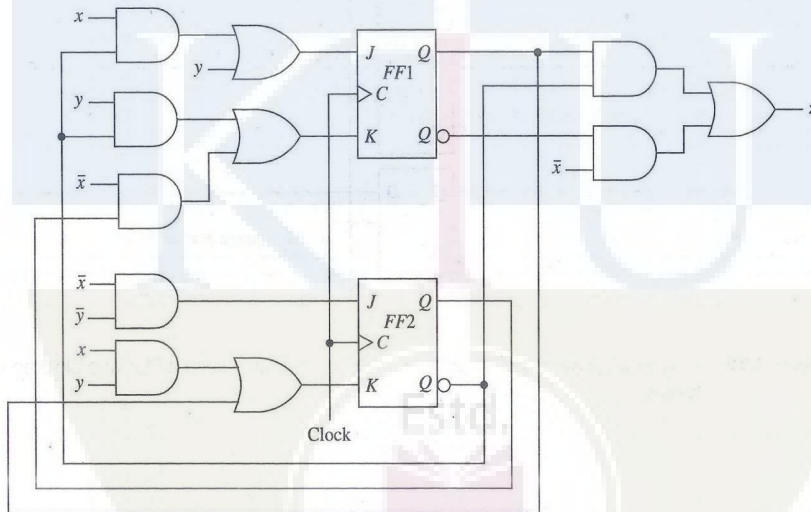

- b. Obtain a minimal state table for a clocked synchronous sequential network having a single input line 'x' in which the symbols 0 and 1 are applied and a single output line 'z'. An output of 1 is to be produced if and only if the 3 input symbols following two consecutive input 0's consist of at least one 1. An example of input/output sequences that satisfy the conditions of the network specifications is:

6

x= 0100010010010010000000011

z= 0000001000000100000000001

CO1
K3

Module - II

13a Analyze the asynchronous sequential network by forming the excitation/transition table, state table, flow table and flow diagram. The network operates in the fundamental mode with the restriction that only one input variable can change at a time.

14

CO2

K4

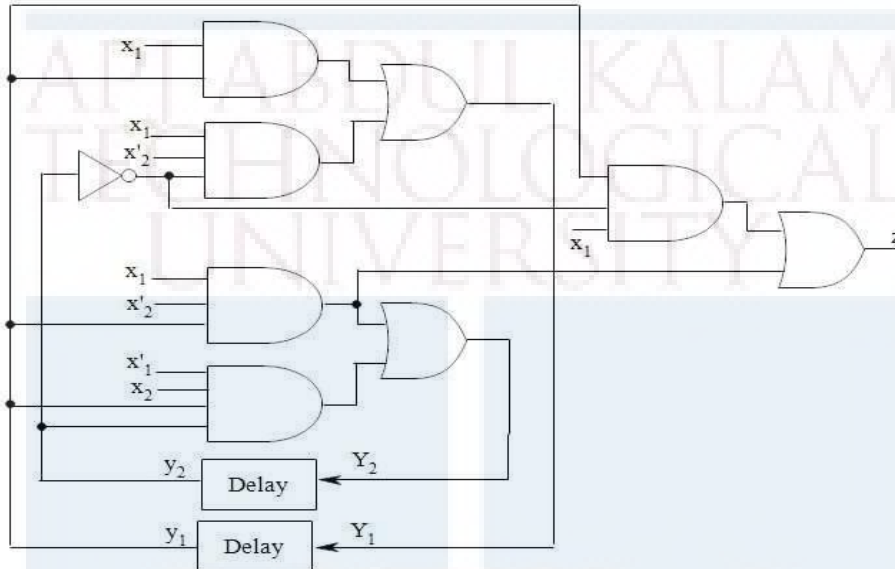

OR

14a A reduced flow table for a fundamental-mode asynchronous sequential network is given below. Using the universal multiple-row state assignment, construct the corresponding expanded flow table and transition table. Assign outputs where necessary such that there is at most a single output change during the time the network is unstable. Assume that the inputs never change simultaneously.

14

CO2

K4

Present state	Next state				Output (z)			
	Input state (x_1x_2)				Input state (x_1x_2)			
	00	01	10	11	00	01	10	11
A	(A)	B	(A)	D	1	-	0	-
B	D	(B)	(B)	C	-	0	1	-
C	A	(C)	(C)	(C)	-	1	1	0
D	(D)	C	A	(D)	0	-	-	1

Module - III

- 15a. Examine the possibility of hazard in the OR-AND logic circuit whose Boolean function is given by $f = \sum(0,2,6,7)$. Show how the hazard can be detected and eliminated. 8
CO3
- b. Explain essential hazards in asynchronous sequential networks. What are the constraints to be satisfied to avoid essential hazards? K3
6

OR

- 16a Draw the logic diagram of the POS expression $Y = (x_1 + x_2')(x_2 + x_3)$. Show that there is a static-0 hazard when x_1 and x_3 are equal to 0 and x_2 goes from 0 to 1. Find a way to remove the hazard by adding one or more gates. 9
CO3
K3

- b Discuss the concept of switch bouncing and suggest a suitable solution. 5
K3

Module - IV

- 17a Illustrate the fault table method used for effective test set generation for the circuit whose Boolean function is $z = \bar{x}_1x_2 + x_3$ 8
CO 4
K3
- b How can the timing problems in asynchronous sequential circuits be solved using mixed operating mode circuits? 6
K3

OR

- 18 Find the test vectors of all SA0 and SA1 faults of the circuit whose Boolean function is $f = \bar{x}_1x_2 + x_1x_2x_3$ by the Kohavi algorithm. 8
CO4
K3
- b. Identify different test pattern generation for BIST 6

2014

CO4
K3**Module - V**

- 19 Explain the architecture of XC 4000 FPGA family. 14
CO5
K2

OR

- 20 Draw and explain the architecture of Xilinx 9500 CPLD family. Also explain the function block architecture. 14
CO5
K2

ECT322	POWER ELECTRONICS	CATEGORY	L	T	P	CREDIT
		PEC	2	1	0	3

Preamble: This course aims to develop the skill of the design of various power electronic circuits.

Prerequisite: ECT201 Solid State Devices, ECT202 Analog Circuits

Course Outcomes: After the completion of the course the student will be able to

CO 1 K2	Understand the characteristics of important power semiconductor switches
CO 2 K3	Apply the principle of drive circuits and snubber circuits for power semiconductor switches
CO 3 K3	Build diode bridge rectifiers and Controlled rectifiers
CO 4 K3	Develop DC – DC Switch-Mode Converter
CO 5 K2	Illustrate the principle of DC – AC Switch-Mode Inverter
CO 6 K3	Apply the principle of power electronics for various applications

Mapping of course outcomes with program outcomes

	PO 1	PO 2	PO 3	PO 4	PO 5	PO 6	PO 7	PO 8	PO 9	PO 10	PO 11	PO 12
CO 1		2			2							
CO 2		3			2							
CO 3		3			2							
CO 4		3			2							
CO 5		2			2							
CO 6		3			2							

Assessment Pattern

Bloom's Category		Continuous Assessment Tests		End Semester Examination
		1	2	
Remember	K1	10	10	10
Understand	K2	30	30	60
Apply	K3	10	10	30
Analyse				
Evaluate				
Create				

Mark distribution

Total Marks	CIE	ESE	ESE Duration
150	50	100	3 hours

Continuous Internal Evaluation Pattern:

Attendance	: 10 marks
Continuous Assessment Test (2 numbers)	: 25 marks
Assignment/Quiz/Course project	: 15 marks

End Semester Examination Pattern: There will be two parts; Part A and Part B. Part A contain 10 questions with 2 questions from each module, having 3 marks for each question. Students should answer all questions. Part B contains 2 questions from each module of which student should answer any one. Each question can have maximum 2 sub-divisions and carry 14 marks.

Course Level Assessment Questions

Course Outcome 1 (CO1): Understand the characteristics of important power semiconductor switches.

1. Illustrate the static and dynamic characteristics, Power BJT, Power MOSFET and IGBT.
2. Illustrate the construction and characteristics of SCR and GTO
3. Model and simulate power semiconductor switches.

Course Outcome 2 (CO2): Apply the principle of drive circuits and snubber circuits for power semiconductor switches.

1. Design the base drive circuits for Power BJT.
2. Design the gate drive circuits for Power MOSFET.
3. Outline the principle of snubber circuits for power switches.
4. Model and simulate above circuits.

Course Outcome 3 (CO3): Build diode bridge rectifiers and Controlled Rectifiers.

1. Explain the operation of three phase diode rectifier and the effect of various loads on the rectifier function
2. Explain the operation of controlled rectifiers and the effect of various loads on the rectifier function
3. Model and simulate diode rectifiers and controlled rectifiers for various loads

Course Outcome 4 (CO4): Develop the principle of DC – DC Switch-Mode Converter

1. Illustrate the principle of DC-DC converters under steady state conditions.
2. Design non-isolated and isolated DC-DC converters for given specifications.
3. Model and simulate non-isolated and isolated DC-DC Switch-Mode converters

Course Outcome 5 (CO5): Illustrate the principle of DC – AC Switch-Mode Inverter.

1. Understand the different types of inverters
2. Construct Driven Inverters for given specifications.
3. Model and simulate Driven Inverters

Course Outcome 6 (CO6): Apply the principle of power electronics for various applications.

1. Illustrate the principle of Adjustable-speed DC drive.
2. Explain the principle of Variable frequency PWM-VSI Induction Motor drives
3. Give at least two applications of power electronic circuits for residential applications.
4. Explain at least two applications of power electronic circuits for industrial applications

SYLLABUS**Module 1 : Power Semiconductor Switches**

Power diodes, Power BJT, Power MOSFET and IGBT - static and dynamic characteristics, SCR and GTO

Module 2 : Protection circuits and Rectifiers

BJT and MOSFET drive circuits, Snubber circuits, Three phase diode bridge rectifiers, Single phase and three phase controlled rectifiers.

Module 3 : DC – DC Switch Mode Converters

Buck, Boost and Buck-boost DC-DC converters

Waveforms and expression of DC-DC converters for output voltage, voltage and current ripple under continuous conduction mode. (No derivation required)

Isolated converters: Flyback, Forward, Push Pull, Half bridge and Full bridge converters –

Waveforms and governing equations (No derivation required)

Module 4 : DC-AC Switch Mode Inverters

Inverter topologies, Driven Inverters : Push-Pull, Half bridge and Full bridge configurations,
Three phase inverter, Pulse width modulation

Module 5 : Applications

DC Motor Drives, Induction Motor Drives, Residential and Industrial applications.

Text Books

1. Umanand L, “Power Electronics: Essentials & Applications”, Wiley India, 2015
2. Ned Mohan, Tore M Undeland, William P Robbins., “Power Electronics: Converters, Applications, and Design”., Wiley India Pvt. Ltd, 3/e, 2015

Reference Books

1. Muhammad H. Rashid., “Power Electronics : Circuits, Devices, and Applications”, Pearson Education India, 4/e, 2014.
2. Daniel W. Hart, Power Electronics, McGraw Hill, 2011.

Course Contents and Lecture Schedule

No	Topic	No. of Lectures
1	Power Semiconductor Switches	
1.1	Power diodes and Bipolar power transistors – structure, static and dynamic characteristics	2
1.2	Power MOSFET and IGBT – structure, static and dynamic characteristics	3
1.3	SCR and GTO – construction and characteristics	2
2	Protection circuits and Rectifiers	
2.1	BJT and MOSFET driver circuits (at least two circuits each)	2
2.2	Snubber circuits – ON and OFF snubbers	1
2.3	Three phase diode bridge rectifiers – basic principles only	1
2.4	Single phase and three phase Controlled rectifiers (with R, RL & RLE loads) – basic principles only	3
3	DC – DC Switch Mode Converters	
3.1	Buck, Boost and Buck-Boost DC-DC converters	2
3.2	Waveforms and expression of DC-DC converters for output voltage, voltage and current ripple under continuous conduction mode (No derivation required)	3
3.3	Isolated converters: Flyback, Forward, Push Pull, Half bridge and Full bridge converters – Waveforms and governing equations (No derivation required)	3
4	DC-AC Switch Mode Inverters	
4.1	Inverter topologies	2
4.2	Driven Inverters: Push-Pull, Half bridge and Full bridge	2

	configurations	
4.3	Three phase inverter	1
4.4	Sinusoidal and Space vector modulation PWM in three phase inverters	2
5	Applications	
5.1	DC Motor Drives – Adjustable-speed DC drive	2
5.2	Induction Motor Drives – Variable frequency PWM-VSI drives	2
5.3	Residential and Industrial applications	2

Assignment:

At least one assignment should be simulation of power electronic circuits using any circuit simulation software.

Simulation Assignments (ECT 322)

The following simulations can be done in LTspice or any other circuit simulation software.

1. Model and simulate BJT test circuit Fig. 1.50 of Umanand L., Power Electronics Essentials and Applications, Wiley India, 2015, page no.48.
2. Model and simulate MOSFET test circuit Fig. 1.51 of Umanand L., Power Electronics Essentials and Applications, Wiley India, 2015, page no.49.
3. Model and simulate IGBT test circuit Fig. 1.52 of Umanand L., Power Electronics Essentials and Applications, Wiley India, 2015, page no.50.
4. Model and simulate BJT drive test circuit Fig. 2.33 of Umanand L., Power Electronics Essentials and Applications, Wiley India, 2015, page no.86.
5. Model and simulate MOSFET drive test circuit Fig. 2.36 of Umanand L., Power Electronics Essentials and Applications, Wiley India, 2015, page no.88.
6. Model and simulate MOSFET shunt snubber test circuit Fig. 2.37 of Umanand L., Power Electronics Essentials and Applications, Wiley India, 2015, page no.89.
7. Model and simulate MOSFET series snubber test circuit Fig. 2.39 of Umanand L., Power Electronics Essentials and Applications, Wiley India, 2015, page no.90.
8. Model and simulate diode rectifiers and controlled rectifiers for various loads.
9. Model and simulate Buck converter circuit Fig. 5.68 of Umanand L., Power Electronics Essentials and Applications, Wiley India, 2015, page no.277.
10. Model and simulate Boost converter circuit Fig. 5.70 of Umanand L., Power Electronics Essentials and Applications, Wiley India, 2015, page no.278.
11. Model and simulate Buck-boost converter circuit Fig. 5.71 of Umanand L., Power Electronics Essentials and Applications, Wiley India, 2015, page no.279.

12. Model and simulate Forward converter circuit Fig. 5.72 of Umanand L., Power Electronics Essentials and Applications, Wiley India, 2015, page no.280.
13. Model and simulate Flyback converter circuit Fig. 5.73 of Umanand L., Power Electronics Essentials and Applications, Wiley India, 2015, page no.281.
14. Model and simulate Driven Inverters
15. Model and simulate Pulse Width Modulator

Model Question paper

APJ ABDUL KALAM TECHNOLOGICAL UNIVERSITY

SIXTH SEMESTER B.TECH DEGREE EXAMINATION, (Model Question Paper)

Course Code: ECT 322

Program: Electronics and Communication Engineering

Course Name: Power Electronics

Max.Marks: 100

Duration: 3Hours

PART A

Answer ALL Questions. Each Carries 3 mark.

1	What is meant by reverse recovery time for a diode	K2	CO1
2	What is the tail current in IGBT ?	K2	CO1
3	What is the purpose of snubber circuits ?	K2	CO2
4	Obtain the expression for average load voltage in three phase full wave bridge rectifier	K3	CO3
5	What is volt-second balancing?	K2	CO4
6	What is the flux walking problem in push-pull converter ?	K2	CO4
7	What is the distinction between chopper, oscillators and inverters ?	K3	CO5
8	Distinguish between driven and self-driven inverters.	K2	CO5
9	How converters are used in induction heating ?	K2	CO6
10	What is regenerative braking in PWM-VSI drive?	K2	CO6

PART – B

Answer one question from each module; each question carries 14 marks.

Module – I				
11(a)	Compare and contrast power BJT, MOSFET and IGBT for switching applications	7	CO 1	K2
11(b)	A diode and a 10 Ω resistor are connected in series to a square wave voltage source of 50V peak. The reverse recovery time for the diode is 200nsec. Find the switching loss of the diode when the input frequency is 100 KHz.	7	CO 1	K3
OR				
12(a)	With the two-transistor model of SCR, explain the working principle of SCR	7	CO 1	K2
12(b)	Illustrate the dynamic characteristics of GTO	7	CO 1	K2
Module – II				
13(a)	Illustrate the base current requirement of power BJT	7	CO 2	K2
13(b)	Explain the operation of any one type of the power BJT base drive circuit	7	CO 2	K2
OR				
14(a)	Illustrate the principle of operation of a single-phase, 2 pulse, fully controlled rectifier for RL load with circuit diagram and waveforms.	10	CO 3	K2
14(b)	Deduce the expression for average load voltage in the circuit.	4	CO 3	K2
Module – III				
15(a)	Explain the operation of Buck-Boost converter and illustrate the operation with the inductor current and switching waveforms.	8	CO 4	K2
15(b)	A Buck-Boost converter that switching at 50 KHz is supplied with an input voltage that varies between 5V to 10V. The output is required to be regulated at 15V. A load resistor of 15 Ω is connected across the output. If the maximum allowable inductor current ripple is 10% of the average inductor current, estimate the value of the inductance to be used in the Buck-Boost converter.	6	CO 4	K3
OR				

16(a)	Describe the principle of operation of the full-bridge converter with circuit diagram and waveforms.	8	CO 4	K2
16(b)	How is the flux walking problem solved in full-bridge converter ?	6	CO 4	K2
Module – IV				
17(a)	Explain the operation of push-pull inverter	8	CO 5	K2
17(b)	Illustrate the PWM switching scheme for sine wave output of the inverter	6	CO 5	K2
OR				
18(a)	Enumerate the principle of operation of three phase inverters	8	CO 5	K2
18(b)	What is Space vector modulation in three phase inverters	6	CO 5	K2
Module – V				
19(a)	Explain the principle of adjustable speed DC drive using switched mode DC-DC converter.	8	CO 6	K2
19(b)	Compare adjustable speed DC drives using switched mode DC-DC converter and line frequency-controlled converter.	6	CO 6	K2
OR				
20 (a)	Illustrate the principle of operation of Variable frequency PWM-VSI Induction Motor drive.	9	CO 6	K2
20(b)	Explain dissipative braking scheme in Induction Motor drive.	5	CO 6	K2

ECT332	DATA ANALYSIS	CATEGORY	L	T	P	CREDIT
		PEC	2	1	0	3

Preamble: This course aims to set the foundation for students to develop new-age skills pertaining to analysis of large-scale data using modern tools.

Prerequisite: None

Course Outcomes: After the completion of the course the student will be able to

CO 1	Read and write data to and fro spreadsheets and databases
CO 2	Work with large data as pandas data frames
CO 3	Perform PCA and cluster analysis on data frames
CO 4	Perform Bayesian analysis on data frames.
CO 5	Apply machine learning in data analysis problems
CO 6	Apply methods in high performance computing for data analysis

Mapping of course outcomes with program outcomes

	PO 1	PO 2	PO 3	PO 4	PO 5	PO 6	PO 7	PO 8	PO 9	PO 10	PO 11	PO 12
CO 1	3	3			3							2
CO 2	3	3	2	3	3							
CO 3	3	3	2	3	3	2						2
CO 4	3	3	2	3	3	2						2
CO 5	3	3	2	3	3	2						2
CO 6	3	3	2	3	3	2						2

Assessment Pattern

Bloom's Category	Continuous Assessment Tests		End Semester Examination
	1	2	
Remember	10	10	20
Understand	30	30	60
Apply	10	10	20
Analyse			
Evaluate			
Create			

Mark distribution

Total Marks	CIE	ESE	ESE Duration
150	50	100	3 hours

Continuous Internal Evaluation Pattern:

Attendance	: 10 marks
Continuous Assessment Test (2 numbers)	: 25 marks
Assignment/Quiz/Course project	: 15 marks

End Semester Examination Pattern: There will be two parts; Part A and Part B. Part A contain 10 questions with 2 questions from each module, having 3 marks for each question. Students should answer all questions. Part B contains 2 questions from each module of which student should answer any one. Each question can have maximum 2 sub-divisions and carry 14 marks.

Course Level Assessment Questions**Course Outcome 1 (CO1): Read and write data to and fro spreadsheets and databases**

1. Write Python code to read an .xls file using xlrd module. Svc it as a different .xlsx file using openpyxl.
2. Write Python code to read mongodb data base.

Course Outcome 2 (CO2): Work with pandas dataframes

1. Write Python code read a table in a pdf file as a pandas dataframe.
2. Write Python code to create a pandas dataframe. Pickle this data and store it. Write another Python code to retrieve the data from the pickle.

Course Outcome 3 (CO3): PCA and Cluster Analysis

1. Write Python code to perform PCA on a pandas dataframe. Write code to create a scree plot.
2. Write Python code to do K-means clustering.

Course Outcome 4 (CO4): Bayesian Analysis on Dataframes

1. Write Python code to compute the posterior probability of a data set with Pymc3
2. Write a python code to evaluate the statistical correlation between variables in 5X5 random data set.

Course Outcome 5 (CO5): Machine learning in Data Analysis

1. Write python code to use Keras for training a CNN
2. Write Python code to read an RGB image and convert to gray scale and write the grayscale image in .jpg format.

Course Outcome 5 (CO6): High Performance Computing Methods in Data analysis

1. Write Python code to use numexpr for faster parallel computation
2. Write Python code with Ipython-parallel to perform parallel computing with 4 cores.

SYLLABUS**Module 1: Overview of Data Analysis and Python**

Numpy and Scipy Python modules for data analysis. Reading and processing spreadsheets and csv files with Python using xlrd, xlwt and openpyxl. Data visualization with Matplotlib. Two dimensional charts and plots. Scatter plots with matplotlib. Three dimensional visualization using Mayavi module. Reading data from sql and mongodb databases with Python.

Module 2: Big Data Arrays with Pandas

Familiarization of the python pandas. Reading and writing pandas dataframes. Reading rows and columns from pandas dataframe. Handling NaN values. Reading and writing .txt, .csv, .pdf, .html and json files with pandas. Merging, concatenating and grouping of data frames. Use of pivot tables. Pickling of data frames in Python.

Module 3: PCA and Cluster Analysis

Singular value decomposition of a matrix/array. Eigen values and eigen vectors. Principal component analysis of a data frame. Scree plot. Dimensionality reduction with PCA. Loadings for principal components. Case study with Python. Cluster analysis. Hierarchical and K-means clustering. Interpretation of dendrograms.

Module 4: Statistical Data Analysis

Hypothesis testing. Bayesian analysis. Meaning of prior, posterior and likelihood functions. Use of pymc3 module to compute the posterior probability. MAP Estimation. Credible interval, conjugate distributions. Contingency table and chi square test. Kernel density estimation.

Module 5: Machine Learning

Supervised and unsupervised learning. Use of scikit-learn. Regression using scikit-learn. Deep learning with convolutional neural networks. Structure of CNN. Use of Keras and Tensorflow. Machine learning with pytorch. Reading and writing images with openCV. Case study of character recognition with MNIST dataset. High performance computing for machine learning. Use of numba, jit and numexpr for faster Python code. Use of Ipython-parallel.

Text Books and References

1. "Python Data Analytics", Fabio Nelli, Apress.
2. "Data Analysis from Scratch with Python", Peters Morgan, AI Sciences.
3. "Python for Data Analysis", Wes McKinny, O'Reilly.
4. "Ipython Interactive Computing and Visualization Cookbook", Cyrille Rossant, PACKT Open Source Publishing
5. "Deep Learning with Python", Francois Chollet, Manning

Course Contents and Lecture Schedule

No	Topic	No. of Lectures
1	Overview of Data Analysis and Python	
1.1	Numpy and Scipy Python modules for data analysis.	2
1.2	Reading and processing spreadsheets and csv files with Python using xlrd, xlwt and openpyxl.	2
1.3	Data visualization with Matplotlib. Two dimensional charts and plots. Scatter plots with matplotlib. Three dimensional visualization using Mayavi module.	2
1.4	Reading data from sql and mongodb databases with Python	2
2	Big Data Arrays with Pandas	
2.1	Intro. To Python pandas	1
2.2	Reading and writing of data as pandas dataframes. Separating header, columns row etc and other manipulations	3
2.3	Reading data from different kind of files, Merging, concatenating and grouping of data frames. Use of pivot tables. Pickling	3
3	PCA and Cluster Analysis	
3.1	Singular value decomposition of a matrix/array. Eigen values and eigen vectors.	1
3.2	PCA, Scree plot. Dimensionality reduction with PCA. Loadings for principal components. Case study with Python. Cluster analysis.	3
3.3	Cluster analysis, dendrograms	2
4	Statistical Data Analysis	
4.1	Hypothesis testing. Bayesian analysis. Meaning of prior, posterior and likelihood functions. Use of pymc3 module to compute the posterior probability.	3
4.2	MAP Estimation. Credible interval, conjugate distributions. Contingency table and chi square test. Kernel density estimation.	3
4.3	Contingency table and chi square test. Kernel density estimation.	3
5	Machine Learning	
5.1	Supervised and unsupervised learning. Use of scikit-learn. Regression using scikit-learn.	2
5.2	Deep learning with convolutional neural networks. Structure of CNN.	2
5.3	Use of Keras and Tensorflow. Machine learning with pytorch. Case study of character recognition with MNIST dataset.	3
5.4	High performance computing for machine learning. Use of numba, jit and numexpr for faster Python code. Use of Ipython-parallel.	2

Simulation Assignments

1. Download the iris data set and read into a pandas data frame. Extract the header and replace with a new header. Extract columns and rows. Extract pivot tables. Filter the data based on the labels. Store a pivot table as a pickle and retrieve it.
2. For the same data set, perform principal component analysis. Observe the scree plot. Identify the principal components. Obtain a low dimensional data, with only the principal components and compute the mean square error between the original data and the approximated one. Compute the loadings for the principal components.
3. For the same data, perform hierarchical and K-means clustering with Python codes. Obtain dendrograms in each case and appreciate the clusters.
4. Download the MNIST letter data set. Construct a CNN network with appropriate layers using Keras and Tensorflow. Train the CNN with the MNIST data set. Appreciate the selection and use of training, test and cross-validation data sets. Save the model and weights and use the model to identify letter images. You may use openCV for reading images.
5. Write a Python script to generate alphanumeric images (26 upper case, 26 lowercase and 10 numbers each 12 point in size) of say 16X16 dimension out of windows .ttf files. Create 62 folders each containing a data set of every alphanumeric character. Create a new CNN with Keras and Tensorflow. Create a cross validation data set by taking 10 images out of every 62 folder. Use 80% of the total data for training and 20% for testing the CNN. Use an HPCC like system to train the model and save the model and weight. Test this model to recognize letter images. You may use openCV for reading images.
6. Repeat assignment 4 using pytorch instead of Keras
7. Repeat assignment 5 using pytorch instead of Keras



Model Question Paper

A P J Abdul Kalam Technological University

Sixth Semester B Tech Degree Examination

Course: ECT 332 Data Analysis

Time: 3 Hrs

Max. Marks: 100

PART A*Answer All Questions*

- 1 Create a two dimensional array of real numbers using numpy. (3) K_3
Write Python code to pickle this data.
- 2 Write Python code to import mayavi module and perform 3-D (3) K_3
visualization of $x^2 + y^2 + z^2 = 1$
- 3 Write Python code to generate a 5×5 pandas data frame of random (3) K_3
numbers. Add a header to this dataframe.
- 4 Write Python code to concatenate two dataframes of same num- (3) K_3
ber of columns.
- 5 Write the expression for the singular value decomposition of a (3) K_3
matrix A
- 6 Explain how principal components are isolated using scree plot. (3) K_1
- 7 State Bayes theorem and explain the significance of the terms prior, (3) K_1
likelyhood and posterior.
- 8 Write Python code with pymc3 to realize a Bernoulli trial with (3) K_3
 $p(head) = 0.2$
- 9 Give the structure a convolutional neural network (3) K_1
- 10 Compare supervised and unsupervised learning (3) K_1

PART B*Answer one question from each module. Each question carries 14 mark.***Module I**

- 11(A) Write Python code to read a spreadsheet in .xls format a text (8) K_3
file in .csv format and put these data into numpy arrays. in
both cases, plot the second column against the first column
using matplotlib
- 11(B) Write Python code to read tables from sql and mongodb (6) K_3
databases.

OR

- 12(A) Write Python code to create a normally distributed 5×5 (8) K_3
random array and convert it into a matrix. Write code to

compute its inverse and transpose.

12(B) Write code to read files in .xlsx format using openpyxl (6) K_3

Module II

13(A) Write Python code to import a table in .xls format into a data frame. Remove all NaN values. (6) K_3

13(B) Write Python code to generate 10 data frames of size 5×5 of random numbers and use a *for loop* to concatenate them. Pickle the concatenated dataframe and store it. Write another code to retrieve the dataframe from the pickle. (8) K_3

OR

14(A) Write Python code to read in a table from a pdf file into a pandas dataframe. Write code to remove the first two columns and write the rest of the dataframe as a json file. (8) K_3

14(B) Explain the term pivot table. Create a pivot table from the above dataframe (6) K_3

Module III

15 Write Python code to read in table in .xls format, perform PCA analysis on it and produce the scree plot and loadings for the principal components. (14) K_3

OR

16. Write Python code to perform hierarchial cluster analysis on a pandas dataframe. Explain how dendrograms can be used to classify data. (14) K_3

Module IV

17(A) Assume that you have a dataset with 57 data points of Gaussian distribution with a mean of 4 and standard deviation of 0.5. Using PyMC3, write Python code to compute: (8) K_3

- The posterior distribution
- The prior distribution
- The posterior predictive distribution

- 17(B) Write a python code to find the Bayesian credible interval in the above question. How is it different from confidence interval. (6) K_3

OR

- 18(A) Write a python code to evaluate the statistical correlation between variables in 10×10 random data set. (8) K_3
- 18(B) Compute the conjugate of the logarithmic function (6) K_3
- $$f(x) = \ln x, x > 0.$$

Module V

- 19(A) Explain the use of numba and numexpr in faster Python execution with examples (8) K_3
- 19(B) Explain the use of Keras as a frontend for Tensorflow with Python codes (6) K_3

OR

- 20(A) Explain the use of Ipython-parallel in parallel execution of Python code with examples. (8) K_3
- 20(B) Explain with Python codes how openCV is used to read and write images. (8) K_3

Estd.



2014

ECT342	EMBEDDED SYSTEMS	CATEGORY	L	T	P	CREDIT
		PEC	2	1	0	3

Preamble: This course aims to design an embedded electronic circuit and implement the same.

Prerequisite: ECT 203 Logic Circuit Design, ECT 202 Analog Circuits ,ECT 206 Computer Architecture and Microcontrollers

Course Outcomes: After the completion of the course the student will be able to

CO 1 K2	Understand and gain the basic idea about the embedded system.
CO 2 K3	Able to gain architectural level knowledge about the system and hence to program an embedded system.
CO 3 K3	Apply the knowledge for solving the real life problems with the help of an embedded system.

Mapping of course outcomes with program outcomes

	PO 1	PO 2	PO 3	PO 4	PO 5	PO 6	PO 7	PO 8	PO 9	PO 10	PO 11	PO 12
CO 1	3	3	2		1			2				2
CO 2	3	3	3		3			2				2
CO 3	3	3	3		3			2	3			2

Assessment Pattern

Bloom's Category		Continuous Assessment Tests		End Semester Examination
		1	2	
Remember	K1	10	10	10
Understand	K2	20	20	20
Apply	K3	20	20	70
Analyse				
Evaluate				
Create				

Mark distribution

Total Marks	CIE	ESE	ESE Duration
150	50	100	3 hours

Continuous Internal Evaluation Pattern:

Attendance	: 10 marks
Continuous Assessment Test (2 numbers)	: 25 marks
Assignment/Quiz/Course project	: 15 marks

End Semester Examination Pattern: There will be two parts; Part A and Part B. Part A contain 10 questions with 2 questions from each module, having 3 marks for each question. Students should answer all questions. Part B contains 2 questions from each module of which student should answer any one. Each question can have maximum 2 sub-divisions and carry 14 marks.

Course Level Assessment Questions

Course Outcome 1 (CO1) : Understand the embedded system fundamentals and system design (K1).

1. Give the challenges of embedded computing.
2. Give the structural description of embedded system.
3. What are the phases of EDLC ?.

Course Outcome 2 (CO2): Understand the peripheral devices and their interfacing with the processor. (K2)

1. Compare and contrast the PCI bus and PCI-X bus.
2. How the ROM memories are classified? Explain.
3. How the peripheral devices are connected with processors?

Course Outcome 3 (CO3): To understand the ARM processor architecture and pipeline processor organization. (K3)

1. Give the architecture of the ARM processor and explain the registers.
2. Explain the pipelined architecture of ARM processor.
3. Write an ARM assembly language program to print the sum of two numbers.

Course Outcome 4 (CO4): To write programs in assembly and high level languages for ARM processor. (K3)

1. Write a note on Thumb single register in ARM processor.
2. Briefly discuss about the Advanced Microcontroller Bus Architecture (AMBA).
3. What are the data types supported by ARM programming high level languages?

Course Outcome 5 (CO5): To understand the basics of real time operating systems and their use in embedded systems. (K2)

1. What are the functions of a Kernel?
2. Describe the process ,” Deadlock”
3. Give the features of a real time operating system.

SYLLABUS

Module 1 : Introduction to Embedded Systems(06 Hours)

1.1 Complex Systems and Microprocessors

Embedding Computers, Characteristics of Embedded Computing Applications, Application of Microprocessors, The Physics of Software, Challenges in Embedded Computing System, Characteristics and quality attributes of an embedded system, Performance in Embedded Computing

1.2 The Embedded System Design Process

Requirements, Specification , Architecture Design, Designing Hardware and Software Components ,System Integration.

1.3 Formalisms for System Design

Structural Description, Behavioral Description, An embedded system design example.

1.4 Embedded product development cycle (EDLC)

Different phases of EDLC, EDLC models

Module 2 : Embedded system interfacing and peripherals (06 Hours)

2.1 Communication devices

Serial Communication Standards and Devices - UART, HDLC and SPI. Serial Bus Protocols - I²C Bus, CAN Bus and USB Bus. Parallel communication standards ISA, PCI and PCI-X Bus.

2.2 Memory

Memory devices and systems – ROM-Flash, EEPROM, RAM-SRAM, DRAM, Cache memory, memory mapping and addresses, memory management unit– DMA .

2.3 I/O Device

Interrupts--Interrupt sources, recognizing an interrupt, ISR – Device drivers for handling ISR, Shared data problem, Interrupt latency.

Module 3 : ARM Processor fundamentals (07 Hours)**3.1 ARM Processor architecture**

The Acorn RISC Machine, Architectural inheritance, The ARM programmer's model, ARM development tools.

3.2 ARM Assembly Language Programming

Data processing instructions, Data transfer instructions, Control flow instructions, writing simple assembly language programs.

3.3 ARM Organization and Implementation

Three stage pipeline ARM organization, Five stage pipeline ARM organization, ARM instruction execution, ARM implementation, The ARM coprocessor interface.

Module 4: ARM Programming (10 Hours)**4.1 Architectural Support for High-Level Languages**

Abstraction in software design, Data types, Floating-point data types, The ARM floating-point architecture, Expressions, Conditional statements, Loops, Functions and procedures, Use of memory, Run-time environment.

4.2 The Thumb Instruction Set

The Thumb bit in the CPSR, The Thumb programmer's model, Thumb branch instructions, Thumb software interrupt instruction, Thumb data processing instructions, Thumb single register data transfer instructions, Thumb multiple register data transfer instructions, Thumb breakpoint instruction, Thumb implementation, Thumb applications.

4.3 Architectural Support for System Development

The ARM memory interface, The Advanced Microcontroller Bus Architecture (AMBA).

4.4 Programming

Assembly and C language programming applications of embedded systems.

Module 5: Real Time Operating Systems (07 Hours)**5.1 Operating system basics**

Kernel, types of operating systems.

5.2 Real time operating systems

Tasks, process, threads, multiprocessing and multi-tasking, task scheduling, types, threads and process scheduling, task communication, task synchronization, device drivers, choosing an RTOS.

Text Books

1. 1. Raj kamal, Embedded Systems Architecture, Programming and Design, TMH, 2003
2. K.V. Shibu, Introduction to Embedded Systems, 2e, McGraw Hill Education India, 2016.
3. Wayne Wolf, Computers as Components: Principles of Embedded Computing System Design, Morgan Kaufman Publishers - Elsevier 3ed, 2008
4. Steve Furber, ARM system-on-chip architecture, Addison Wesley, Second Edition, 2000

Reference Books

1. David E. Simon, An Embedded Software Primer, Pearson Education Asia, First Indian Reprint 2000.
2. Steve Heath, Embedded Systems Design, Newnes – Elsevier 2ed, 2002
3. Andrew N. Sloss, Dominic Symes, Chris Wright, ARM System Developer's Guide Designing and Optimizing System Software, Morgan Kaufmann Publishers 2004
4. Frank Vahid and Tony Givargis, Embedded Systems Design – A Unified Hardware / Software Introduction, John Wiley, 2002.
5. Tammy Noergaard, Embedded Systems Architecture, A Comprehensive Guide for Engineers and Programmers, Newnes – Elsevier 2ed, 2012
6. Iyer - Embedded Real time Systems, 1e, McGraw Hill Education New Delhi, 2003
7. Lyla B. Das, Embedded Systems: An Integrated Approach, 1/e , Lyla B. Das, Embedded Systems, 2012

Course Contents and Lecture Schedule

No	Topic	No. of Lectures
1	Introduction to Embedded Systems	
1.1	Complex Systems and Microprocessors	2
1.2	The Embedded System Design Process	1
1.3	Formalisms for System Design	2
1.4	Embedded product development cycle (EDLC)	1
2	Embedded system interfacing and peripherals	
2.1	Communication devices	3
2.2	Memory	2
2.3	I/O Device	2

3	ARM Processor fundamentals	
3.1	ARM Processor architecture	2
3.2	ARM Assembly Language Programming	3
3.3	ARM Organization and Implementation	2
4	ARM Programming	
4.1	Architectural Support for High-Level Languages	2
4.2	The Thumb Instruction Set	3
4.3	Architectural Support for System Development	2
4.4	Programming	3
5	Real Time Operating Systems	
5.1	Operating system basics	2
5.2	Real time operating systems	5

Simulation Assignments:

1. At least one assignment should be of programming (Both assembly and C languages) of embedded processor with simulation tools like Keil, Eclipse.
2. Another assignment should be an embedded system design mini project.

Programming assignments can be the following

- (a) Print "HELLO WORLD" or any text
- (b) Data transfer, copy operations
- (c) Arithmetic operations
- (d) Sorting operations
- (e) input/output control
- (f) programs using functions
- (g) Interrupts and ISR
- (h) controller design

Mini project can be done in the following areas.

- (a) Elevator controller design
- (b) Chocolate vending machine design
- (c) Industrial controller using sensors
- (d) IOT applications using sensors, communication devices and actuators

Model Question paper**APJ ABDUL KALAM TECHNOLOGICAL UNIVERSITY**SIXTH SEMESTER B.TECH DEGREE EXAMINATION, (**Model Question Paper**)**Course Code: ECT342****Course Name: EMBEDDED SYSTEM DESIGN**

Max. Marks: 100

Duration: 3 Hours

PART A

(Answer ALL Questions. Each Question Carries 3 Marks.)

1. Define an embedded system
2. Write any 3 challenges of embedded system design
3. Explain how an RS232 device is interfaced to a processor
4. What is interrupt latency?
5. Write the contents of CPSR register of ARM processor and their use.
6. Draw the five stage pipeline architecture of ARM processor
7. What is the use of thumb instruction set in ARM processor?
8. What a note on ARM memory interface
9. What is a real time operating system?
10. What are tasks, processes and threads? [10 X 3= 30]

PART – B

(Answer one question from each module; each question carries 14 marks)

Module – I

11. (a) What are the characteristics of an embedded system? Explain. [07 Marks]
- (b) Explain the different phases of EDLC. [07 Marks]

OR

12. (a) Write different steps involved in the embedded system design process. [07Marks]
- (b) Explain the structural description of embedded system design. [07 Marks]

Module – II

13. (a) What is serial and parallel port communication? Explain with the help of necessary diagrams. [07 Marks]

(b) What is interrupt? How interrupts are handled in a processor? Explain ISR.[07 Marks]

OR

14. (a) With the help of a diagram show how ROM and RAM are interfaced to a processor. Explain the read/write processes. [07 Marks]

(b) Explain how a memory management unit is used in a processor. What are its uses? What is DMA ? [07 Marks]

Module – III

15. (a) Write a note on ARM processor architecture and its registers. [07 Marks]

(b) Write a note on data processing and data transfer instructions with the help of examples [07 Marks]

OR

16. (a) What is pipeline architecture? Explain how an ARM instruction is executed in a 5 stage pipeline processor with the help of an example. [08 Marks]

(b) Write an ARM assembly language program to print text string “Hello World”. [06 Marks]

Module – IV

17. (a) Explain ARM floating point architecture and discuss how floating point numbers are handled [07 Marks]

(b) Write a note on Thumb single register and multiple register data transfer instructions with the help of examples. [07 Marks]

OR

18. (a) What is Thumb instruction set? Why it is used? Explain Thumb programmers model. [07 Marks]

(b) Draw the block diagram of AMBA architecture. What are the different types of buses used in the architecture? [07 Marks]

Module V

19. (a) What are the different services of Kernel? Explain different types of Kernels. [07Marks]

(b) Explain pre-emptive and non-pre-emptive scheduling algorithms with the help of an example. [07 Marks]

OR

20. (a) What are the basic functions of real time Kernel? Explain. [07 Marks]

(b) Write a note on the following (a) shared memory (b) message passing (c) deadlock [07 Marks]

APJ ABDUL KALAM
TECHNOLOGICAL
UNIVERSITY

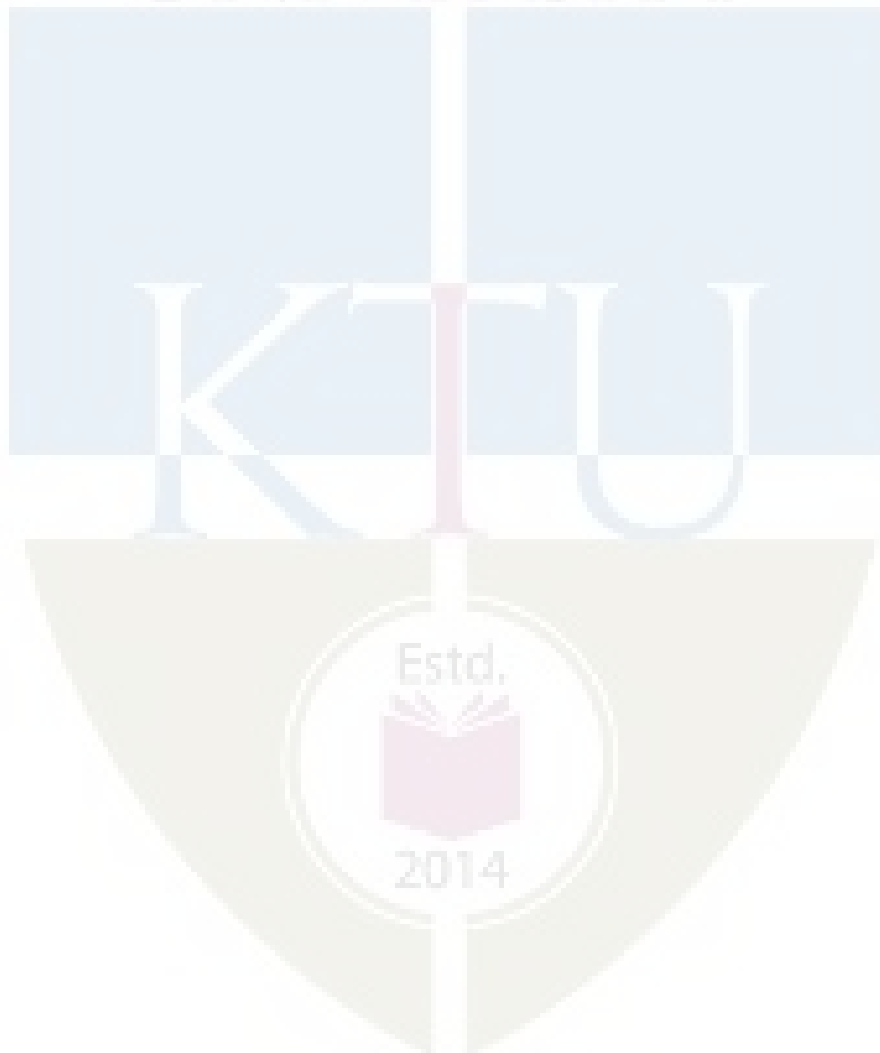

ECT352	DIGITAL IMAGE PROCESSING	CATEGORY	L	T	P	CREDIT
		PEC	2	1	0	3

Preamble: This course aims to develop the skills for methods of various transformation and analysis of image enhancement, image reconstruction, image compression, image segmentation and image representation.

Prerequisite: ECT 303 Digital Signal Processing

Course Outcomes: After the completion of the course the student will be able to

CO 1	Distinguish / Analyse the various concepts and mathematical transforms necessary for image processing
CO 2	Differentiate and interpret the various image enhancement techniques
CO 3	Illustrate image segmentation algorithm
CO 4	Understand the basic image compression techniques

Mapping of course outcomes with program outcomes

	PO 1	PO 2	PO 3	PO 4	PO 5	PO 6	PO 7	PO 8	PO 9	PO 10	PO 11	PO 12
CO 1	3	3	2		1							2
CO 2	3	3	2		1							2
CO 3	3	3	3		1							2
CO 4	3	3	3		1							2

Assessment Pattern

Bloom's Category		Continuous Assessment Tests		End Semester Examination
		1	2	
Remember	K1	10	10	10
Understand	K2	20	20	20
Apply	K3	20	20	70
Analyse	K4			
Evaluate				
Create				

Mark distribution

Total Marks	CIE	ESE	ESE Duration
150	50	100	3 hours

Continuous Internal Evaluation Pattern:

Attendance: 10 marks

Continuous Assessment Test (2 numbers) : 25 marks

Assignment/Quiz/Course project : 15 marks

End Semester Examination Pattern: There will be two parts; Part A and Part B. Part A contain 10 questions with 2 questions from each module, having 3 marks for each question. Students should answer all questions. Part B contains 2 questions from each module of which student should answer any one. Each question can have maximum 2 sub-divisions and carry 14 marks. The questions must have 50% representation from theory, and 50% representation from logical/numerical/derivation/proof.

Course Level Assessment Questions

Course Outcome 1 (CO1): Analyze the various concepts and restoration techniques for image processing

1. For the given image check whether pixel P and Q have 8 connectivity.
2. Find filtered image using median filter.
3. Explain Weiner filtering.

Course Outcome 2 (CO2): Differentiate and interpret the various image enhancement techniques

1. Classify different image enhancement process. Differentiate between spatial domain and frequency domain techniques of image enhancement.
2. What is histogram equalisation? Briefly discuss the underlying logic behind histogram equalisation.
3. Apply mean and median filters over a given image.

Course Outcome 3 (CO3): Illustrate image segmentation algorithm

1. Name two basic approaches of image segmentation and mention their differences.
2. How can you decide optimal thresholds when the image contains a background and several foreground objects? Write down a corresponding algorithm.
3. Write down the region growing algorithm. What are its advantages and disadvantages?

Course Outcome 4 (CO4): Analyze basic image compression techniques

1. What do you mean by compression ratio? Do you consider that lower compression ratio ensures better images upon reproduction?
2. How can achievable compression ratio to be determined from image histogram?
3. Mention the steps of lossy and lossless JPEG compression

SYLLABUS**Module 1**

Digital Image Fundamentals: Image representation, basic relationship between pixels, elements of DIP system, elements of visual perception-simple image formation model. Vidicon and Digital Camera working principles Brightness, contrast, hue, saturation, mach band effect

Colour image fundamentals-RGB, CMY, HIS models, 2D sampling, quantization.

Module 2

Review of matrix theory: row and column ordering- Toeplitz, Circulant and block matrix

2D Image transforms: DFT, its properties, Walsh transform, Hadamard transform, Haar transform, DCT, KL transform and Singular Value Decomposition.

Image Compression: Need for compression, Basics of lossless compression – bit plane coding, run length encoding and predictive coding, Basics of lossy compression – uniform and non-uniform quantization techniques used in image compression, Concept of transform coding, JPEG Image compression standard.

Module 3

Image Enhancement: Spatial domain methods: point processing- intensity transformations, histogram processing, image subtraction, image averaging. Spatial filtering- smoothing filters, sharpening filters.

Frequency domain methods: low pass filtering, high pass filtering, homomorphic filter

Module 4

Image Restoration: Degradation model, Unconstraint restoration- Lagrange multiplier and constraint restoration

Inverse filtering- removal of blur caused by uniform linear motion, Weiner filtering,

Geometric transformations-spatial transformations

Module 5

Image segmentation: Classification of Image segmentation techniques, region approach, clustering techniques. Segmentation based on thresholding, edge based segmentation. Classification of edges, edge detection, Hough transform, active contour.

Text Books

1. Gonzalez Rafael C, Digital Image Processing, Pearson Education, 2009
2. S Jayaraman, S Esakkirajan, T Veerakumar, Digital image processing, Tata Mc Graw Hill, 2015

Reference Books

1. Jain Anil K , Fundamentals of digital image processing: , PHI,1988
2. Kenneth R Castleman , Digital image processing:, Pearson Education,2/e,2003
3. Pratt William K , Digital Image Processing: , John Wiley,4/e,2007

Course Contents and Lecture Schedule

No.	Topic	No. of Lectures
1	Digital Image Fundamentals	
1.1	Image representation, basic relationship between pixels, elements of DIP system, elements of visual perception-simple image formation model	3
1.2	Vidicon and Digital Camera working principles	1
1.3	Brightness, contrast, hue, saturation, mach band effect	1
1.4	Colour image fundamentals -RGB, CMY, HIS models	1
1.5	2D sampling, quantization.	1
2	Review of matrix theory	
2.1	Row and column ordering- Toeplitz, Circulant and block matrix	2
2.2	2D Image transforms : DFT, its properties, Walsh transform, Hadamard transform, Haar transform	3
2.3	DCT, KL transform and Singular Value Decomposition.	3
2.4	Image Compression: Need for compression, Basics of lossless compression – bit plane coding, run length encoding and predictive coding, Basics of lossy compression – uniform and non-uniform quantization techniques used in image compression, Concept of transform coding, JPEG Image compression standard..	2
3	Image Enhancement	
3.1	Spatial domain methods: point processing- intensity transformations, histogram processing, image subtraction, image averaging	2
3.2	Spatial filtering- smoothing filters, sharpening filters	1
3.3	Frequency domain methods: low pass filtering, high pass filtering, homomorphic filter.	2
4	Image Restoration	
4.1	Degradation model, Unconstraint restoration- Lagrange multiplier and constraint restoration	2
4.2	Inverse filtering- removal of blur caused by uniform linear motion, Weiner filtering	2
4.3	Geometric transformations-spatial transformations	2
5	Image segmentation	
5.1	Classification of Image segmentation techniques, region approach, clustering techniques	2
5.2	Segmentation based on Thresholding, edge based segmentation	2
5.3	Classification of edges, edge detection, Hough transform, active contour	3

Simulation Assignments

The following simulations be done in Scilab/ Matlab/ LabView:

1. Read Image data into the workspace.
2. Determine various transforms using matlab functions.
3. Detect and measure circular objects in an image.
4. Adjust the contrast of the given image.
5. Filter images using predefined filter.
6. Create degraded images affected by motion blur and noise by simulating the models for both. Apply inverse filtering and Weiner filtering methods to the simulated images and compare their performance.
7. Detect an object against the background using various edge detection algorithms and compare their performance.
8. Create a histogram for a gray scale image.
9. Create image at various compression level.
10. Use texture segmentation to identify region based on their texture.

Model Question paper**APJ ABDUL KALAM TECHNOLOGICAL UNIVERSITY**SIXTH SEMESTER B.TECH DEGREE EXAMINATION, (**Model Question Paper**)**Course Code: ECT352****Course Name: DIGITAL IMAGE PROCESSING**

Max. Marks: 100

Duration: 3 Hours

PART A

Answer all questions, each carries 3 marks.

1. Give mathematical representation of digital images? Write down the names of different formats used. K2
2. Explain mach band effect. K2
3. What is SVD? Explain its applications in digital image processing. K3
4. Write the similarity and difference between Hadamard and Walsh transforms K3
5. What are the advantages and disadvantages of block processing K2
6. Name the role of point operators in image enhancement K2
7. What is median filter? Explain the operation in 2D noise image with salt and pepper noise K3
8. Distinguish between linear and nonlinear image restoration. K3
9. Mention the use of derivative operation in edge detection. K4
10. The Pewitt edge operator is much better than Robert operator. Why? Give the matrix. K3

PART B**Answer any one full questions, from each module carries 14 marks.**

Module 1

1. a) State and explain the 2D sampling theorem. Explain how aliasing errors can be eliminated? (7 marks)
- b) Define the terms brightness, contrast, hue and saturation with respect to a digital image. Explain the terms False contouring and Machband effect. (K1 – CO1) (7 marks)

OR

2. a) Explain elements of visual perception simple image formation model in detail (K1 – CO1) (8 marks)
- b) Explain various color image models and its transformations (K1 - CO1) (6 marks)

Module 2

3. a) Explain the difference between DST and DCT. (K2 - CO1) (4 marks)
- b) Compute the 2D DFT of the 4x4 gray scale image given below. (K3-CO1) (10 marks)

$$f(x, y) = \begin{bmatrix} 1 & 1 & 1 & 1 \\ 1 & 1 & 1 & 1 \\ 1 & 1 & 1 & 1 \\ 1 & 1 & 1 & 1 \end{bmatrix}$$

OR

4. a) Construct a Harr transform matrix for N=4. (4 marks) (K3-CO1)
 b) Compute the 8-point DCT for following data $X=\{2,4,6,8,10,6,4,2\}$. (10 marks)

Module 3

5. a) List histogram image enhancement techniques? Explain each one in detail. (10 marks)
 K2-CO2
 b) Write a note on color image enhancement. (K2-CO2) (4 marks)

OR

6. a) Describe the following in detail (i) Histogram equalization (ii) LPF and HPF in image enhancement (iii) high boost filters (10 marks)

Module 4

7. a) Assume 4x4 image and filter the image using median filter of 3x3 neighbourhood. Use replicate padding. (K3—CO1) (8 marks)
 b) Explain the digital image restoration. (K1—CO1) (6 marks)

OR

8. a) Explain inverse filtering with necessary equations. (K1-CO1) (6 marks)
 b) Differentiate various noise models. (K2-CO1) (8 marks)

Module 5

9. a) Explain the active contour algorithm for image segmentation any four geometric transformations on an image. (K2-CO3) (7 marks)
 c) Assume 4x4 image and filter the image using median filter of 3x3 neighbourhoods. Use replicate padding (K3—CO1) (7 marks)

OR

10. a) Explain global, adaptive and histogram based thresholding in detail. (7 marks)
 c) Explain Hough transform in detail (7 marks)

ECT362	INTRODUCTION TO MEMS	CATEGORY	L	T	P	CREDIT
		PEC	2	1	0	3

Preamble: This course introduces students to the rapidly emerging, multi-disciplinary, and exciting field of Micro Electro Mechanical Systems.

Prerequisite: EST130-Basics of Electrical and Electronics Engineering, EST 100-Engineering Mechanics

Course Outcomes

CO1	Describe the working principles of micro sensors and actuators
CO2	Identify commonly used mechanical structures in MEMS
CO3	Explain the application of scaling laws in the design of micro systems
CO4	Identify the typical materials used for fabrication of micro systems
CO5	Explain the principles of standard micro fabrication techniques
CO6	Describe the challenges in the design and fabrication of Micro systems

Mapping of course outcomes with program outcomes

	PO1	PO2	PO3	PO4	PO5	PO6	PO7	PO8	PO9	PO10	PO11	PO12
CO1	3	3										
CO2	3	3										
CO3	3	3										
CO4	3	3	2									
CO5	3	3										
CO6	3	3										

Assessment Pattern

Bloom's Category	Continuous Assessment Tests		End Semester Examination
	1	2	
Remember	10	10	20
Understand	30	30	60
Apply	10	10	20
Analyse			
Evaluate			
Create			

Mark distribution

Total Marks	CIE	ESE	ESE Duration
150	50	100	3 hours

Continuous Internal Evaluation Pattern:

Attendance	: 10 marks
Continuous Assessment Test (2 numbers)	: 25 marks
Assignment/Quiz/Course project	: 15 marks

End Semester Examination Pattern: There will be two parts; Part A and Part B. Part A contain 10 questions with 2 questions from each module, having 3 marks for each question. Students should answer all questions. Part B contains 2 questions from each module of which student should answer any one. Each question can have maximum 2 sub-divisions and carry 14 marks.

Course Level Assessment Questions

Course Outcome 1 (CO1): Describe the working principles of micro sensors and actuators

1. Explain the principle of operation of two types of micro-accelerometers
2. Explain with relevant examples how the principle of electrostatics may be used for the design of MEMS based sensors and actuators.
3. Explain how smart materials can be used for the design of MEMS based sensors and actuators.

Course Outcome 2 (CO2): Identify commonly used mechanical structures in MEMS

1. Explain the purpose of micro cantilevers in MEMS systems. What is the relevance of spring constant (k) of a mechanical structure in micro system design?
2. Derive the expression for the magnitude of applied bending moment with reference to pure bending of longitudinal beams.
3. Explain how plates and diaphragms can be used for the design

Course Outcome 3(CO3): Explain the application of scaling laws in the design of micro systems

1. Explain force scaling vector, what information does it provide to a MEMS designer?
2. Derive equations for acceleration a , time t and power density P/V based on the Trimmer Force Scaling Vector?
3. Explain why electrostatic actuation is preferred over electromagnetic actuation at the micro-scale.

Course Outcome 4 (CO4): Identify the typical materials used for fabrication of micro systems

1. State the relevant properties of Silicon Carbide and Silicon Nitride for use in Microsystems.
2. Explain why Silicon evolved as the ideal substrate material for MEMS fabrication.
3. Explain with examples the advantages of use of polymers in micro systems fabrication?

Course Outcome 5 (CO5): Explain the principles of standard micro fabrication techniques

1. Explain the steps involved in photolithography. State the chemicals used in each of the stages along with the operating conditions.
2. Explain the criteria for choice of surface or bulk micromachining techniques in the design of micro systems.
3. Explain with block diagram the steps in LIGA process. State two advantages of LIGA process over other micro machining techniques.

Course Outcome 6 (CO6): Describe the challenges in the design, fabrication and packaging of Micro systems

1. Explain the challenges involved in the packaging of Microsystems as compared to microelectronic devices
2. Discuss the various fabrication challenges associated with surface micromachining.

SYLLABUS**MODULE I**

MEMS and Microsystems: Applications – multidisciplinary nature of MEMS – principles and examples of Micro sensors and micro actuators – micro accelerometer –comb drives - Micro grippers – micro motors, micro valves, micro pumps, Shape Memory Alloys.

Actuation and Sensing techniques: Thermal sensors and actuators, Electrostatic sensors and actuators, Piezoelectric sensors and actuators, magnetic actuators

MODULE II

Review of Mechanical concepts: Stress, Strain, Modulus of Elasticity, yield strength, ultimate strength – General stress strain relations – compliance matrix. Overview of commonly used mechanical structures in MEMS - Beams, Cantilevers, Plates, Diaphragms – Typical applications

Flexural beams: Types of Beams, longitudinal strain under pure bending – Deflection of beams – Spring constant of cantilever – Intrinsic stresses

MODULE III

Scaling laws in miniaturization - scaling in geometry, scaling in rigid body dynamics, Trimmer force scaling vector, scaling in electrostatic and electromagnetic forces, scaling in electricity and fluidic dynamics, scaling in heat conducting and heat convection.

Materials for MEMS – Silicon – Silicon compounds – Silicon Nitride, Silicon Dioxide, Silicon carbide, Poly Silicon, GaAs , Silicon Piezo resistors. Polymers in MEMS – SU-8, PMMA, PDMS, Langmuir – Blodgett Films.

MODULE IV

Micro System fabrication – Photolithography – Ion implantation- Diffusion – Oxidation – Chemical vapour deposition – Etching

Overview of Micro manufacturing – Bulk micro manufacturing, Surface micro machining , LIGA process –Microstereo lithography

MODULE V

Micro system Packaging: general considerations in packaging design – Levels of Micro system packaging. Bonding techniques for MEMS: Surface bonding, Anodic bonding, Silicon - on - Insulator, wire bonding, Sealing – Assembly of micro systems.

Overview of MEMS areas : RF MEMS, BioMEMS, MOEMS, NEMS

Text Books:

1. Chang Liu, Foundations of MEMS, Pearson 2012
2. Tai-Ran Hsu, MEMS and Microsystems Design and Manufacture, TMH, 2002

Reference Books:

1. Chang C Y and Sze S. M., VLSI Technology, McGraw-Hill, New York, 2000
2. Julian W Gardner, Microsensors: Principles and Applications, John Wiley & Sons, 1994
3. Mark Madou, Fundamentals of Micro fabrication, CRC Press, New York, 1997
4. Stephen D. Senturia, Microsystem design, Springer (India), 2006.
5. Thomas B. Jones, Electromechanics and MEMS, Cambridge University Press, 2001
6. Gregory T.A. Kovacs, Micromachined Transducers Sourcebook, McGraw Hill, 1998

Course Contents and Lecture Schedule

No	Topic	No. of Lectures
1.1	Introduction to MEMS and Microsystems	1
1.2	Applications – multidisciplinary nature of MEMS – principles and examples of Micro sensors and micro actuators – micro accelerometer, comb drives -	1
1.3	Micro grippers – micro motors,	1
1.4	micro valves, micro pumps, Shape Memory Alloys.	1
1.5	Actuation and Sensing techniques : Thermal sensors and actuators,	1
1.6	Electrostatic sensors and actuators	1
1.7	Piezoelectric sensors and actuators,	1
1.8	magnetic actuators	1

2.1	Review of Mechanical concepts: Stress, Strain, Modulus of Elasticity, yield strength, ultimate strength	1
2.2	General stress strain relations – compliance matrix.	1
2.3	Overview of commonly used mechanical structures in MEMS - Beams, Cantilevers, Plates, Diaphragms – Typical applications	1
2.4	Flexural beams: Types of Beams, longitudinal strain under pure bending	2
2.5	Deflection of beams – Spring constant of cantilever, Intrinsic stresses	1
3.1	Scaling laws in miniaturization - scaling in geometry, scaling in rigid body dynamics, Trimmer force scaling vector,	2
3.2	scaling in electrostatic and electromagnetic forces	1
3.3	scaling in electricity and fluidic dynamics,	1
3.4	scaling in heat conducting and heat convection	1
3.5	Materials for MEMS – Silicon – Silicon compounds- Silicon Nitride	1
3.6	Silicon Dioxide, Silicon carbide	1
3.7	Poly Silicon, GaAs , Silicon Piezo resistors	1
3.8	Polymers in MEMS – SU-8, PMMA,	1
3.9	PDMS, Langmuir – Blodgett Film	1
4.1	Micro System fabrication,Photolithography– Ion implantation	2
4.2	Diffusion, Oxidation	1
4.3	Chemical vapour deposition, Etching	1
4.4	Overview of Micro manufacturing – Bulk micro manufacturing,	1
4.5	Surface micro machining	1
4.6	LIGA process	1
4.7	Microstereo lithography	1
5.1	Micro system Packaging: general considerations in packaging design	1
5.2	Levels of Micro system packaging	1
5.3	Bonding techniques for MEMS : Surface bonding , Anodic bonding	1
5.4	Silicon - on - Insulator , wire bonding	1
5.5	Sealing – Assembly of micro systems	1
5.6	Overview of MEMS areas : RF MEMS, BioMEMS, MOEMS, NEMS	1

A P J Abdul Kalam Technological University
 Sixth Semester B Tech Degree Examination
Course: ECT 362 Introduction to MEMS
Time: 3 Hrs Max. Marks: 100

PART A

Answer All Questions

- | | | |
|----|--|---|
| 1 | State an example to justify the multidisciplinary nature of MEMS | 3 |
| 2 | State three applications of MEMS devices in the automotive industry | 3 |
| 3 | Define normal stress and strain, how it is different from shear stress and strain | 3 |
| 4 | Determine the stress in the longitudinal direction of a Silicon rod with rectangular cross section is pulled on both ends with a force of 10mN. The dimensions of the rod being 1 mm X 100 μ m X 50 μ m. | 3 |
| 5 | Define the Trimmer force scaling vector | 3 |
| 6 | State one application each of PDMS and PMMA in MEMS fabrication | 3 |
| 7 | Discuss the criteria for selecting materials for the masks used in etching | 3 |
| 8 | Define etch stop? State the different methods used to stop etching | 3 |
| 9 | State the various levels of micro system packaging | 3 |
| 10 | State two applications of NEMS | 3 |

PART B

Answer one question from each module. Each question carries 14 marks.

Module I

- | | | |
|-------|--|---|
| 11(A) | Sketch and explain the working of a silicon capacitive accelerometer attached to a comb drive | 6 |
| 11(B) | Explain the operating principle of piezoelectric sensors and actuators with relevant sketches. | 8 |

OR

- | | | |
|-------|--|---|
| 12(A) | Explain the operating principle of thermal bimorphs with neat sketches. State any two applications of thermal sensors. | 8 |
| 12(B) | Explain the principle of operation of the following micro sensors (i) Comb drives (ii) Shape Memory Alloys | 6 |

Module II

- | | | |
|-------|---|---|
| 13(A) | Determine the force constant associated with the two beams (a) and (b) shown in figure below. Which is stiffer, justify with arguments. | 8 |
|-------|---|---|

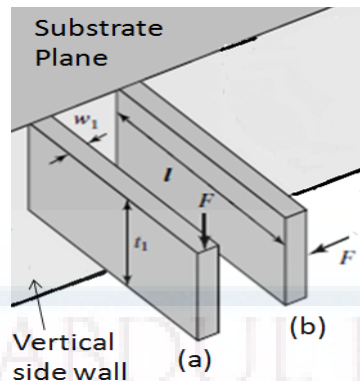

- 13(B) Explain with neat sketches the longitudinal strain experienced by segment of beam (with rectangular cross-section) under pure bending. 6

OR

- 14(A) Explain the general stress strain relationship and arrive at the compliance matrix 8
- 14(B) Explain with neat sketches the type of mechanical beams and boundary conditions associated with supports 6

Module III

- 15(A) Explain in the light of scaling, assuming a 10 times reduction of size of the actuator. Which of the electrostatic and electromagnetic forces are best suited for micro device actuation. 8
- 15(B) State three relevant properties of Silicon Carbide and Silicon Nitride for use in Microsystems 6

OR

- 16(A) Explain various scaling laws in miniaturization 6
- 16(B) State the constraints in pumping fluids in micro channels. What pumping scheme is usually used in micro fluidics, state one example? 8

Module IV

- 17(A) Explain the steps involved in photolithography. State the chemicals used in each of the stages along with the operating conditions 6
- 17(B) Compare and contrast various micro manufacturing techniques 8

OR

- 18(A) Describe the various mechanical problems associated with surface micromachining 6
- 18(B) Explain the LIGA process associated with MEMS fabrication 8

Module V

- 19(A) Explain the following bonding techniques with figures a) Silicon-on-Insulator b) Wire bonding 8
- 19(B) Explain the challenges involved in BioMEMS. List three applications of BioMEMS. 8

OR

- 20(A) Explain with diagrams any two applications of RFMEMS 8
- 20(B) Explain the challenges involved in designing packages for micro systems 6

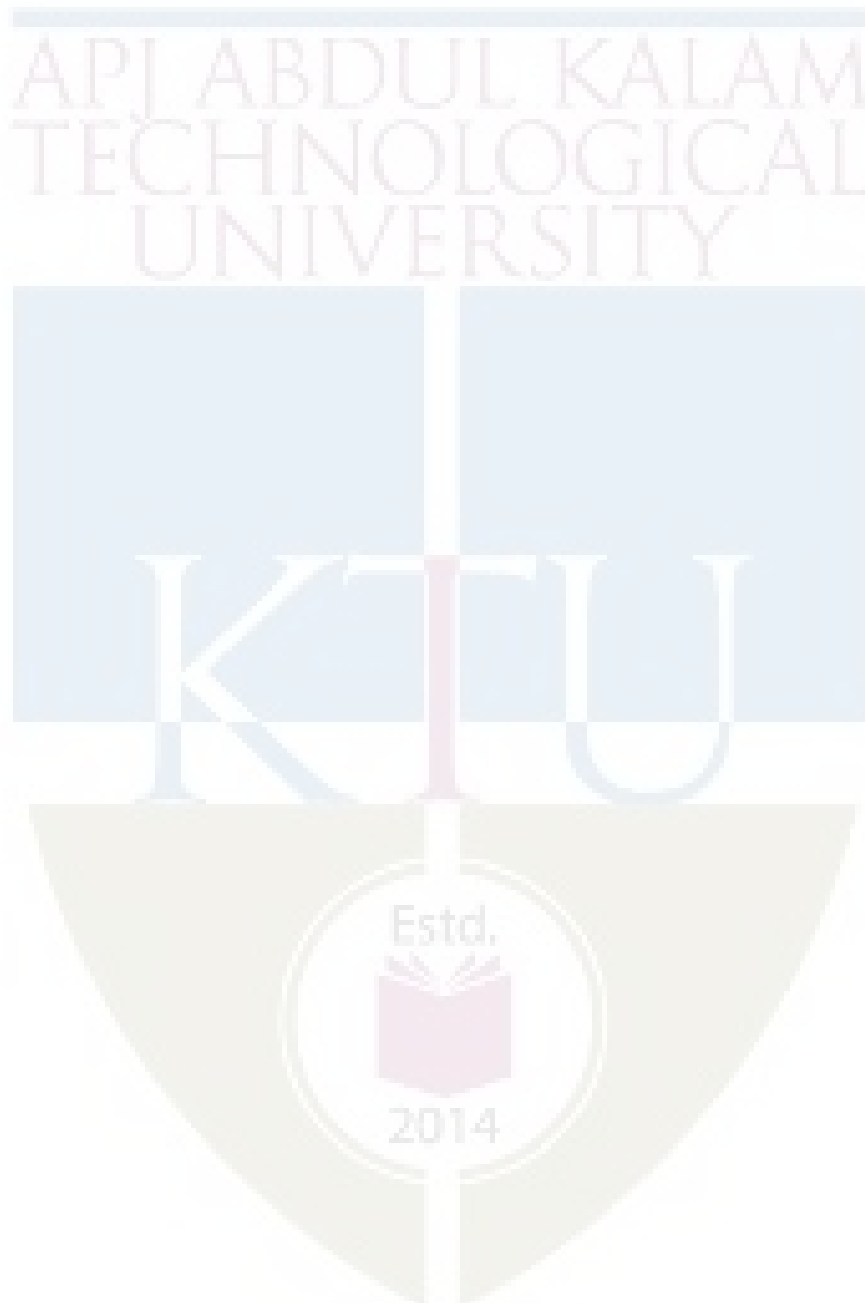

ECT372	QUANTUM COMPUTING	CATEGORY	L	T	P	CREDIT
		PEC	2	1	0	3

Preamble: Quantum computers are not yet built. If such machines become a reality, they will fundamentally change how we perform calculations, and the implications on many applications (including communications and computer security) will be tremendous. This course aims to provide a first introduction to quantum computing with a general understanding of how quantum mechanics can be applied to computational problems. It highlights the paradigm change between conventional computing and quantum computing, and introduce several basic quantum algorithms.

Prerequisite: MAT101 Linear Algebra and Calculus

Course Outcomes: After the completion of the course the student will be able to

CO 1 K2	Explain the basic constructs in linear algebra needed to build the concepts of quantum computing
CO 2 K2	Relate the postulates of quantum mechanics for computation and illustrate/ demonstrate quantum measurement
CO 3 K3	Identify quantum gates and build quantum circuit model in which most of the quantum algorithms are designed.
CO 4 K4	Analyse and design quantum algorithms and grasp the advantage they offer over classical counterparts.

Mapping of course outcomes with program outcomes

	PO 1	PO 2	PO 3	PO 4	PO 5	PO 6	PO 7	PO 8	PO 9	PO 10	PO 11	PO 12
CO1	3	3										2
CO2	3	3										2
CO3	3	3	3									2
CO4	3	3	3	2								2

Assessment Pattern

Bloom's Category		Continuous Assessment Tests		End Semester Examination
		1	2	
Remember	K1	10	10	10
Understand	K2	20	20	20
Apply	K3	20	10	50
Analyse	K4		10	20
Evaluate				
Create				

Mark distribution

Total Marks	CIE	ESE	ESE Duration
150	50	100	3 hours

Continuous Internal Evaluation Pattern:

Attendance	: 10 marks
Continuous Assessment Test (2 numbers)	: 25 marks
Assignment/Quiz/Course project	: 15 marks

End Semester Examination Pattern: There will be two parts; Part A and Part B. Part A contain 10 questions with 2 questions from each module, having 3 marks for each question. Students should answer all questions. Part B contains 2 questions from each module of which student should answer any one. Each question can have maximum 2 sub-divisions and carry 14 marks.

Course Level Assessment Questions**Course Outcome 1 (CO1): Explain the basic constructs in linear algebra needed to build the concepts of quantum computing (K2)**

1. Summarise the basic operators and matrices required for understanding the quantum computing concepts.
2. Find the Eigen values and Eigen vectors of Pauli matrices.
3. Explain spectral decomposition and Spectral theorem. State the spectral theorem for Hermitian operator.
4. Show the matrix representation of the tensor products of the Pauli operators

Course Outcome 2 (CO2): Relate the postulates of quantum mechanics for computation and illustrate/ demonstrate quantum measurement (K2)

1. State and explain the postulates of Quantum Mechanics applied to computing.
2. Show the Bloch sphere representation of quantum bits.
3. Find the various states of a given system using state space analysis.
4. Demonstrate the state space representation of composite systems using tensor product.

Course Outcome 3 (CO3): Identify quantum gates and build quantum circuit model in which most of the quantum algorithms are designed (K3)

1. Model universal gates using standard quantum gates.
2. Illustrate the implementation of quantum operation using quantum gates.
3. Construct and prove circuit identities.
4. Construct a circuit for implementing controlled U operations
5. Design quantum circuits that implements projective measurement in the computational basis.

Course Outcome 4 (CO4): Analyse and design quantum algorithms and grasp the advantage they offer over classical counterparts (K4)

1. Design a circuit that implements Quantum Fourier Transform(QFT) for an n-bit input.
2. Construct the phase estimation algorithm from basic principles and design the circuit for phase estimation using QFT.
3. Interpret phase estimation algorithm for the implementation of order finding and factorisation algorithms.

SYLLABUS

Module 1: Basics of Linear Algebra

History and Overview of Quantum Computation and Quantum Information, Linear Algebra Basics, Linear Operators and matrices, The Pauli matrices, Inner Products, Eigen values and Eigen vectors, Hermitian operators and Adjoints, Spectral theorem, Tensor Products.

Module 2: Basics of Quantum Mechanics

State Space Representation - Bloch Sphere, State Evolution – Unitary transformation, Quantum measurement – Projective measurements, Composite systems - Superposition.

Module 3: Quantum Gates and Circuits

Quantum gates – Hadamard gate, NOT gate, controlled-NOT gate, Toffoli gate, Realisation of classical gates with quantum gates – Z Gate, Fredkein Gate, Pauli Matrices – Controlled Swap and Controlled U-operations, Circuit Identities

Module 4: Quantum Measurement

Basic principle of quantum measurement - Principle of deferred measurement, Principle of implicit measurement, Gates with projective measurements, Universal quantum gates, Universality of two level unitary gates.

Module 5: Algorithms

Quantum Fourier Transform (QFT) – Quantum circuit for QFT, Quantum phase estimation, Modular exponentiation, Order finding and factorisation – Deutsch’s algorithm.

Text Books

1. M. A. Nielsen and I. L. Chuang, Quantum Computation and Quantum Information, Cambridge, UK, Cambridge University Press, 2010.
2. J. Gruska, Quantum Computing, McGraw Hill, 1999.
3. G. Strang, Linear algebra and its applications (4th Edition), Thomson, 2006.

Reference Books

1. P. Kaye, R. Laflamme, and M. Mosca. An Introduction to Quantum Computing. Oxford, 2007.
2. Eleanor G. Rieffel, Wolfgang H. Polak, “Quantum Computing: A Gentle Introduction,” MIT Press, 2011.
3. Noson Yanofsky and Mirco Mannucci, “Quantum Computing for Computer Scientists”, Cambridge University Press, 2008.
4. Abhijith, J., Adedoyin, Adetokunbo, Ambrosiano, John (and 30 others), “Quantum Algorithm Implementations for Beginners”, [arXiv:1804.03719](https://arxiv.org/abs/1804.03719), 2020.

Course Contents and Lecture Schedule

No	Topic	No. of Lectures
1	Basics of Linear Algebra	
1.1	History and Overview of Quantum Computation and Quantum Information	1
1.2	Linear Algebra Basics	1
1.3	Linear Operators and matrices	1
1.4	Pauli matrices	1
1.5	Inner Products, Eigen values and Eigen vectors	1
1.6	Hermitian operators and Adjoints, Spectral theorem	2
1.7	Tensor Products	2
2	Basics of Quantum Mechanics	
2.1	State Space Representation - Bloch Sphere	1
2.2	State Evolution – Unitary transformation	2
2.3	Quantum measurement – Projective measurements	2
2.4	Composite systems - Superposition	2
3	Quantum Gates and Circuits	
3.1	Quantum gates – Hadamard gate, NOT gate, controlled-NOT gate, Toffoli gate	2
3.2	Realisation of classical gates with quantum gates – Z Gate, Fredkin Gate	2
3.3	Pauli Matrices – Controlled Swap and Controlled U-operations	2
3.4	Circuit Identities	1
4	Quantum Measurement	
4.1	Basic principle of quantum measurement - Principle of deferred measurement, Principle of implicit measurement	1
4.2	Gates with projective measurements	2
4.3	Universal quantum gates	1

4.4	Universality of two level unitary gates	2
5	Algorithms	
5.1	Quantum Fourier Transform (QFT)	1
5.2	Quantum circuit for QFT Quantum phase estimation	2
5.3	Modular exponentiation	1
5.4	Order finding and factorisation – Deutsch's algorithm	2

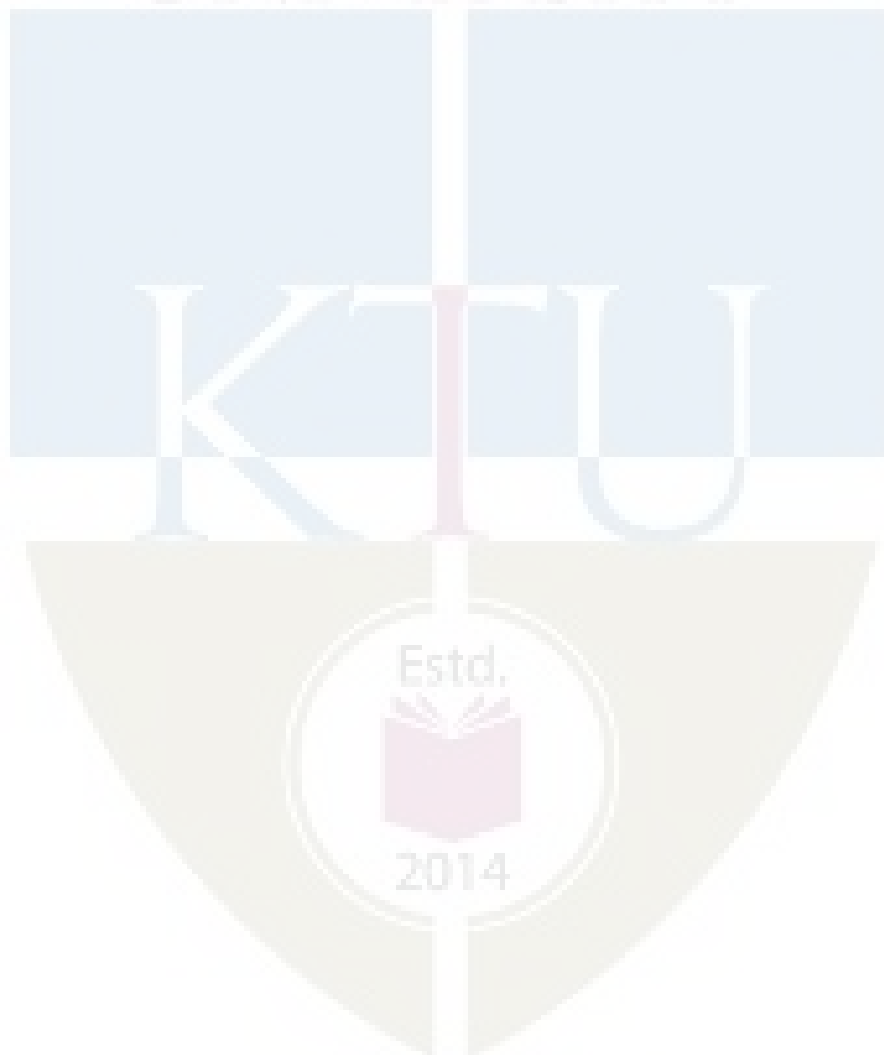

APJ ABDUL KALAM TECHNOLOGICAL UNIVERSITY

SIXTH SEMESTER B.TECH DEGREE EXAMINATION, (Model Question Paper)

Course Code: ECT372

Course Name: QUANTUM COMPUTING

Max. Marks: 100

Duration: 3 Hours

PART A

Answer ALL Questions. Each Carries 3 mark.

- 1 Consider the operator from $\mathbb{C}^2 \rightarrow \mathbb{C}^2$ given by $T(x,y) = (ix, iy)$, where $Z^2 = -1$. Find the matrix representation of the Transformation. K2
- 2 Write the Eigen values and Eigen vectors of the matrix $\begin{bmatrix} 2 & 1 \\ 1 & 2 \end{bmatrix}$. Is this operator Hermitian? K1
- 3 Write down the Bloch sphere representation of the Quantum bit $\frac{1}{2}|0\rangle + \frac{j}{\sqrt{2}}|1\rangle$. K1
- 4 Suppose the first bit of a two bit Quantum System whose state given by $\alpha|00\rangle + \beta|01\rangle + \chi|10\rangle + \delta|11\rangle$ is measured
 - a. What is the probability that the first bit is observed to be 0?
 - b. Suppose that the first bit is observed to be 0, then what is the resultant state of the system?K3
5. Compute the resultant state of the given circuit for input state $|00\rangle$. K3

6 What is the 4×4 unitary matrix U for the circuit given below K2

- 7 State the two basic principles of quantum measurement and explain it's uses. K1
- 8 For the given circuit, 0 was observed by measuring the second bit. What is the resultant Quantum State of the first bit? K3

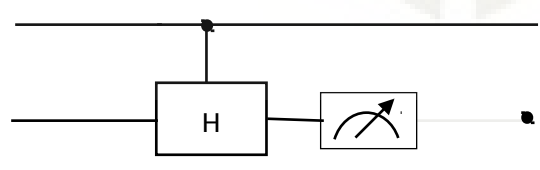

- 9 Give a decomposition of the controlled-Rk gate into single qubit and C_{NOT} gates. K2
- 10 Draw the 3 input Quantum Fourier Transform (QFT) circuit. K2

Answer one question from each module; each question carries 14 marks.

Module - I

- 11 a. Find the eigenvectors and eigenvalues of the following four matrices: 7

$$\sigma_0 = \begin{bmatrix} 1 & 0 \\ 0 & 1 \end{bmatrix} \quad \sigma_1 = \begin{bmatrix} 0 & 1 \\ 1 & 0 \end{bmatrix} \quad \sigma_2 = \begin{bmatrix} 0 & -i \\ i & 0 \end{bmatrix} \quad \sigma_3 = \begin{bmatrix} 1 & 0 \\ 0 & -1 \end{bmatrix}$$

CO1

K2

- b. Give the eigenvalues and eigenvectors of this matrix 7

$$\begin{bmatrix} 1 & 0 & 0 & 0 \\ 0 & 0 & 1 & 0 \\ 0 & 1 & 0 & 0 \\ 0 & 0 & 0 & 1 \end{bmatrix}$$

CO1

K3

OR

- 12 a. A matrix M is Hermitian if $M^\dagger = M$. Let M be Hermitian. 7

i. Prove that all of its eigenvalues are real. CO1

ii. Prove that $v^\dagger M v$ is real, for all vectors v. When $v^\dagger M v > 0$, we say that $M > 0$. K3

- b. Let M be Hermitian, and define 7

$$U = e^{iM} = \sum_k \frac{(iM)^k}{k!}$$

CO1

Prove that $U^\dagger U = I$, where I is the identity matrix. For matrix M, let $M^\dagger = (M^T)^*$, where M^T is the transpose of M, and * denotes the complex conjugate of M. K3

Module - II

- 13 a. What is a Quantum State. Explain with examples 2

CO2

K2

- b. Consider the following two-qubit quantum state, $|\varphi\rangle$. 12

$$\frac{\sqrt{2}}{3\sqrt{3}}|00\rangle - \frac{1}{\sqrt{6}}|01\rangle + \frac{2i\sqrt{2}}{3\sqrt{3}}|10\rangle + \frac{5i}{3\sqrt{6}}|11\rangle$$

i. What are the probabilities of outcomes 0 and 1 if the first qubit of $|\varphi\rangle$ is measured? CO2

ii. What are the probabilities of outcomes 0 and 1 if the second qubit of $|\varphi\rangle$ is measured? K3

iii. What is the state of the system after the first qubit of $|\varphi\rangle$ is measured to be a 0?

iv. What is the state of the system if the second qubit of $|\varphi\rangle$ is measured to be a 1?

v. What are the probabilities of outcomes 0 and 1 if the second qubit of the system is measured, after the first qubit of $|\varphi\rangle$ has been measured to be 0?

vi. What are the probabilities of outcomes 0 and 1 if the first qubit of the system is measured, after the second qubit of $|\varphi\rangle$ has been measured to be 1?

- 14 a. State and explain the four postulates of Quantum Mechanics applied to computing. 8
CO2
K2
- b. Which quantum state do we get if we apply $(H \otimes I)$ CNOT to

$$\frac{1}{\sqrt{3}}|00\rangle + \frac{2}{\sqrt{3}}|11\rangle$$
 6
CO2

Here I is the 1-qubit identity operation, H is the 1-qubit Hadamard, and CNOT is the 2-qubit controlled-not operation with the first (=leftmost) qubit being the control. K3

What is the probability of seeing $|11\rangle$ if we measure the resulting state in the computational basis?

Module - III

- 15 a. Show that $XYX = -Y$ and use this to prove that $X R_y(\theta) X = R_y(-\theta)$. 7
CO3
K3
- b. An arbitrary single qubit unitary operator can be written in the form 7
 $U = \exp(i\alpha) R_{\hat{n}}(\theta)$. for some real numbers α and θ , and a real three-dimensional unit vector \hat{n} . CO3
K3
- i. Prove this fact.
 - ii. Find values for α , θ , and \hat{n} giving the Hadamard gate H.
 - iii. Find values for α , θ , and \hat{n} giving the phase gate.

OR

- 16 a. It is useful to be able to simplify circuits by inspection, using well-known identities. 7
Prove the following three identities:
- i. $HXH = Z$ CO3
 - ii. $HYH = -Y$ K3
 - iii. $HZH = X$
- b. Show that 7
CO3
K3

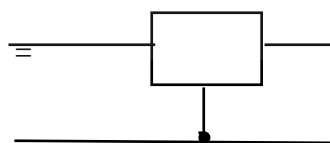
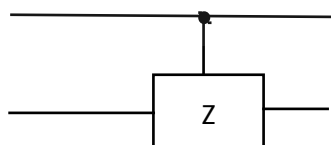

Module - IV

- 17 Suppose we have a single qubit operator U with eigenvalues ± 1 , so that U is both Hermitian and unitary. Suppose we wish to measure the observable U . How can this be implemented by a quantum circuit? Show that the following circuit implements a measurement of U . 14
CO3
K3

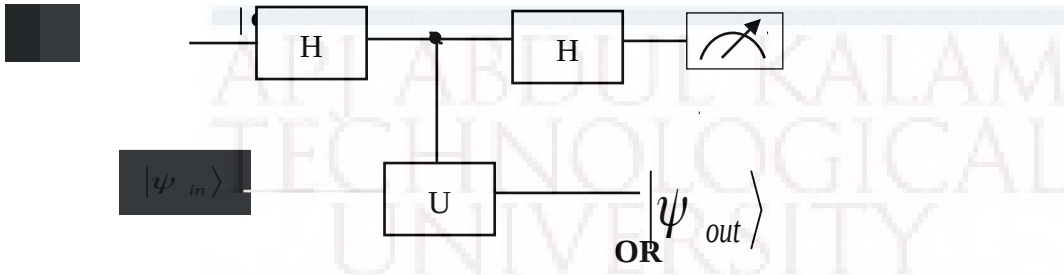

- 18 a. Derive the circuit implementing the controlled-U operation for an arbitrary single qubit U , using only single qubit operations and the CNOT gate. 7
CO3
K4
- b. Using just CNOTs and Toffoli gates, construct a quantum circuit to perform the transformation given below. 7
CO3

$$\begin{bmatrix} 1 & 0 & 0 & 0 & 0 & 0 & 0 & 0 \\ 0 & 0 & 0 & 0 & 0 & 0 & 0 & 1 \\ 0 & 1 & 0 & 0 & 0 & 0 & 0 & 0 \\ 0 & 0 & 1 & 0 & 0 & 0 & 0 & 0 \\ 0 & 0 & 0 & 1 & 0 & 0 & 0 & 0 \\ 0 & 0 & 0 & 0 & 1 & 0 & 0 & 0 \\ 0 & 0 & 0 & 0 & 0 & 1 & 0 & 0 \\ 0 & 0 & 0 & 0 & 0 & 0 & 1 & 0 \end{bmatrix}$$

K4

Module - V

- 19 a. Derive the circuitry for computing a 4-input Quantum Fourier Transform (QFT). 7
CO4
K3
- b. The two qubit Quantum Fourier Transform is given by the following matrix. 7

$$F_2 = \frac{1}{2} \begin{bmatrix} 1 & 1 & 1 & 1 \\ 1 & i & -1 & -i \\ 1 & -1 & 1 & -1 \\ 1 & -i & -1 & i \end{bmatrix}$$

CO4

K3

Sketch a circuit for implementing the operator F_2 using any combination of 1-qubit Hadamard gates; 1-qubit Pauli gates; 2-qubit CNOT gates and controlled phase shifts. Briefly explain your circuit.

OR

- 20 a. Explain the phase estimation algorithm using Quantum Fourier Transform (QFT). 8
Derive the circuitry for the Quantum Phase estimation. CO4
K3
- b. Apply Quantum phase estimation to estimate the phase of a T-Gate. 6
CO4
K4

APJ ABDUL KALAM
TECHNOLOGICAL
UNIVERSITY

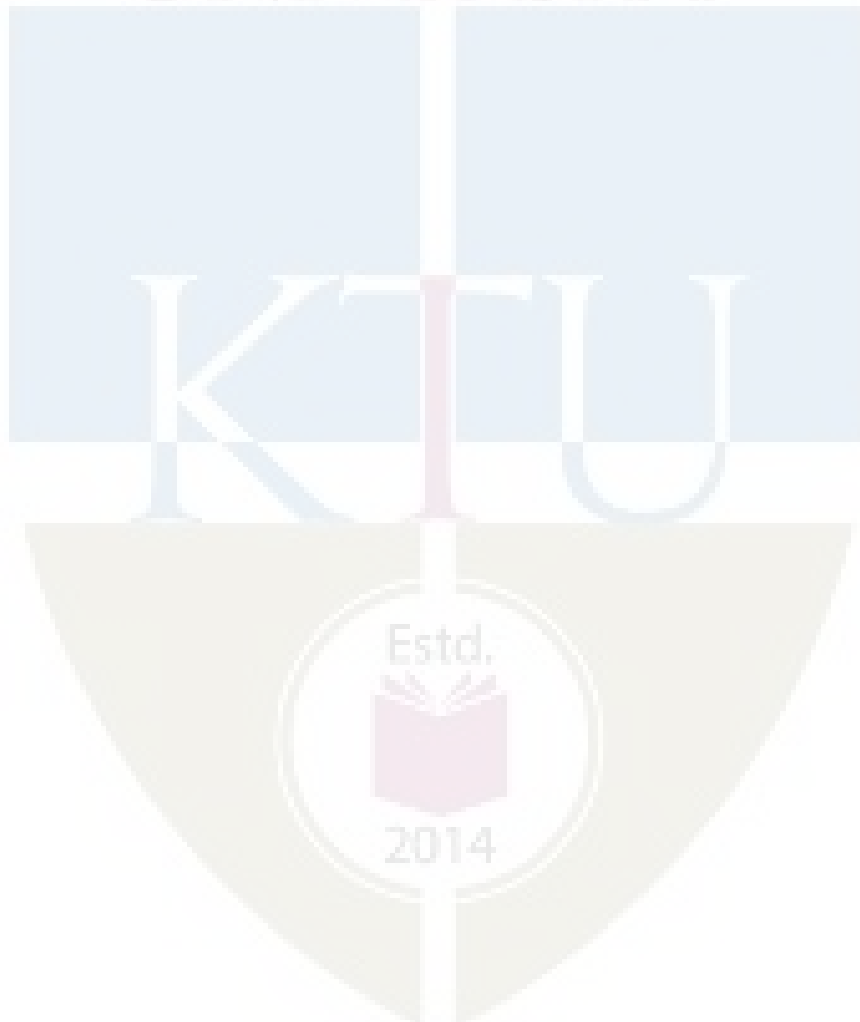

APJ ABDUL KALAM
TECHNOLOGICAL
UNIVERSITY

SEMESTER VI

MINOR



ECT382	VLSI CIRCUITS	CATEGORY	L	T	P	CREDIT
		VAC	3	1	0	4

Preamble: This course aims to impart the knowledge about the fundamentals of Digital Systems, MOSFETs, basic VLSI circuits and Application Specific Integrated Circuits.

Prerequisite: ECT281 Electronic Circuits

Course Outcomes: After the completion of the course the student will be able to:

CO1	Explain the working of various functional building blocks used in digital system design
CO2	Explain Structure and working of MOSFETS and basic VLSI circuits using MOSFET
CO3	Explain the circuit technique used to implement dynamic logic and storage cells
CO4	Explain the application specific integrated circuit design flow and design approached
CO5	Explain the programmable logic cells, programming technologies, different type of i/o cells and different timing constraints in ASIC design

Mapping of course outcomes with program outcomes:

	PO1	PO2	PO3	PO4	PO5	PO6	PO7	PO8	PO9	PO10	PO11	PO12
CO1	3	2	3								2	3
CO2	3	2	2		1							3
CO3	3	2	2		1							3
CO4	3	3	3		3						3	3
CO5	3	3	3		3						3	3

Assessment Pattern:

Bloom's Category		Continuous Assessment Tests		End Semester Examination
		1	2	
Remember	K1	15	15	30
Understand	K2	25	25	50
Apply	K3	10	10	20
Analyse				
Evaluate				
Create				

Mark distribution:

Total Marks	CIE	ESE	ESE Duration
150	50	100	3Hrs

Continuous Internal Evaluation Pattern:

Attendance	: 10 marks
Continuous Assessment Test (2 numbers)	: 25 marks
Assignment/Quiz/Course project	: 15 marks

End Semester Examination Pattern**Maximum Marks: 100****Time: 3 hours**

End Semester Examination Pattern: There will be two parts; Part A and Part B. Part A contain 10 questions with 2 questions from each module, having 3 marks for each question. Students should answer all questions. Part B contains 2 questions from each module of which student should answer any one. Each question can have maximum 2 sub-divisions and carry 14 marks. Mark patterns are as per the syllabus with 75% for theory and 25% for logical/numerical problems.

Course Level Assessment Questions.**Course Outcome 1 (CO1):**

1. With circuit and truth table, explain the working of a full adder.
2. Explain the use of 2m:1 multiplexer for realizing a logic function of m variables.
3. With circuit and truth table, explain the working of a 4 bit ripple counter

Course Outcome 2 (CO2):

1. Draw the structure of a n-channel MOSFET and describe its working
2. Explain the static characteristics of NMOS inverter and derive its pull up to pull down impedance ratio
3. Draw the circuit diagram of two input NAND gate in CMOS logic and represent it using its stick diagram

Course Outcome 3 (CO3):

1. Describe the basic principle of dynamic logic with necessary diagrams
2. Explain the working of np domino logic. What is its merits and demerits over domino logic?
3. Explain the working of one transistor Dynamic Memory Cell.

Course Outcome 4 (CO4):

1. Explain and compare the full custom and semicustom IC design methods
2. Describe the Top-Down and Bottom-Up design methodologies using in ASIC design
3. Discuss the Speed power and area considerations in VLSI design

Course Outcome 5 (CO5):

1. Explain a multiplexer based programmable logic cells
2. Describe the programmable array based logic implementation in Altera MAX
3. Define setup time, hold time, propagation delay, clock to output delay

Syllabus**Module 1: Basic Building Blocks in Digital Systems (12 Hrs)**

Basic logic gates, binary adder, subtractor, magnitude comparator, decoders, encoders, multiplexers, simple examples for combinational circuits (discuss with respective truth tables) Sequential circuits, Latched and flip-flops, clocked sequential circuits, registers, shift registers, counters (analysis not required)

Module 2: MOSFET Fundamentals and basic VLSI circuits (9 Hrs)

Structure and working principle of MOSFETS, VI characteristics, current equations (derivations not required), NMOS and CMOS inverter circuits, static characteristics and comparison, implementation of CMOS logic gates, stick diagram representation, Layout Design and Design rules- Lambda rules and micron rules (Definitions only).

Module 3: Dynamic logic Design and Storage Cells (8 Hrs)

Dynamic Logic Design-Pre charge- Evaluate logic, Domino Logic, NP domino logic. Read Only Memory-4x4 MOS ROM Cell Arrays (NOR) Random Access Memory –SRAM-Six transistor CMOS SRAM cell, DRAM –Three transistor and One transistor Dynamic Memory Cell.

Module 4: VLSI Design Methodologies (7 Hrs)

Introduction: Moore slow .ASIC design, Full custom ASICs, Standard cell based ASICs, Gate array based ASICs, SoCs, FPGA devices, ASIC and FPGA Design flows Top-Down and Bottom-Up design methodologies. Logical and Physical design. Speed power and area considerations in VLSI design

Module 5: FPGA Architecture(8 Hrs)

Programmable logic cells: multiplexer based logic cells(ACT1), lookup table based logic implementation(XC3000 CLB), programmable array based logic implementation (Altera MAX).
ASIC programming technologies: antifuse, SRAM, EPROM, EEPROM
Different types of I/O cells used in programmable ASICs

Timing constraints in ASIC design: setup time, hold time, propagation delay, clock to output delay, critical path (concept only)

Text Books:

1. M. Morris Mano, Digital Design 3/e, Prentice Hall of India, 2002.
2. M. J. S. Smith, Application Specific Integrated Circuits, Pearson Education,2007
3. Sung –Mo Kang & Yusuf Leblebici, CMOS Digital Integrated Circuits- Analysis & Design, McGraw-Hill, Third Ed., 2003

References:

1. Thomas Floyds, Digital Fundamentals, 11th edition, Pearson Publication, 2015
2. Neil H.E. Weste, Kamran Eshraghian, Principles of CMOS VLSI Design- A Systems Perspective, Second Edition. Pearson Publication, 2005.
3. Jan M. Rabaey, Digital Integrated Circuits- A Design Perspective, Prentice Hall, Second Edition, 2005.

Course Contents and Lecture Schedule

No	Topic	No. of Lectures
Module 1: Basic Building Blocks in Digital Systems (12 hours)		
1.1	Basic logic gates,	1
1.2	binary adder, subtractor	2
1.3	magnitude comparator, decoders, encoders	1

1.4	multiplexers, simple examples for combinational circuits	2
1.5	Sequential circuits, Latches and flip-flops	2
1.6	clocked sequential circuits, registers, shift registers, counters	4
Module 2: MOSFET Fundamentals and basic VLSI circuits (9 hours)		
2.1	Structure and working principle of MOSFETS	1
2.2	VI characteristics, current equations	1
2.3	NMOS and CMOS inverter circuits, static characteristics and comparison	3
2.4	Implementation of CMOS logic gates	2
2.5	Stick diagram representation, Layout Design and Design rules- Lambda rules and micron rules (Definitions only)	2
Module 3: Dynamic logic Design and Storage Cells (7 hours)		
3.1	Dynamic Logic Design-Pre charge- Evaluate logic	1
3.2	Domino Logic, NP domino logic	2
3.3	ROM, Ram and DRAM	4
Module 4: VLSI Design Methodologies. (8 hours)		
4.1	Introduction: Moore slaw .ASIC design,	1
4.2	Full custom ASICs, Standard cell based ASICs, Gate array based ASICs, SoCs, FPGA devices	3
4.3	ASIC and FPGA Design flows Top-Down and Bottom-Up design methodologies.	2
4.4	Logical and Physical design. Speed power and area considerations in VLSI design	2
Module 5: FPGA Architecture (9 hours)		
5.1	Programmable logic cells: multiplexer based logic cells(ACT1), lookup table based logic implementation(XC3000 CLB), programmable array based logic implementation (Altera MAX).	3
5.2	ASIC programming technologies: antifuse, SRAM, EPROM, EEPROM	2
5.3	Different types of I/O cells used in programmable ASICs	2
5.4	Timing constraints in ASIC design: setup time, hold time, propagation delay, clock to output delay, critical path	2

Model Question Paper**A P J Abdul Kalam Technological University**

Sixth Semester B Tech Degree Examination

Course: **ECT 382 VLSI CIRCUITS**

Time: 3 Hrs Max.

Marks: 100

PART A*(Answer All Questions)*

- 1 Which are the universal gates and why are they called as universal gates? (3)
- 2 Draw the circuit diagram to realize a modulo 15 down counter (3)
- 3 Draw VI characteristics of n- channel MOSFET and clearly mark different regions (3)
- 4 Define lambda rules and micron rules. (3)
- 5 List out the merits and drawbacks of np domino over domino logic (3)
- 6 Explain the working of one transistor Dynamic Memory Cell. (3)
- 7 Explain Moore slow in VLSI design (3)
- 8 Differentiate between full custom and semicustom design methods in ASIC design. (3)
- 9 List different types of I/O cells used in programmable ASICs. (3)
- 10 What is mean by critical path in an ASIC? (3)

PART B*(Answer one question from each module. Each question carries 14 mark.)*

- 11 (a) With circuit and truth table, explain the working of a full adder. Also draw the schematic of 4 bit binary adder using full adder blocks (8)
 - (b) Construct a circuit to convert four bit serial data to parallel data and explain its working. (6)
- OR**
- 12 (a) Realize a 16:1 multiplexer using four bit multiplexers and basic gates. Also explain it using its switching expression (8)
 - (b) Explain the working of JK flip flop with its circuit and truth table (6)
- 13 (a) Draw VI characteristics of n-channel MOSFET and explain it with the current equation (8)

- (b) Draw the circuit diagram of a two input CMOS NAND gate (6)

OR

- 14 (a) Draw the stick diagram and Layout of a CMOS inverter (8)
- (b) Explain any 5 Lambda based design rules (6)
- 15 (a) Explain the Pre charge- Evaluate phase in the dynamic logic. (6)
- (b) Draw a 4x4 MOS ROM Cell Array and explain its working (8)

OR

- 16 (a) With neat schematic diagram, explain the working of NP domino logic. What is its advantage over domino logic? (8)
- (b) Explain the working of a three transistor DRAM cell (6)
- 17 (a) What is FPGA? What are its applications? With block diagram explain its internal architecture? (7)
- (b) Explain ASIC design flow. (7)

OR

- 18 (a) Explain the Top-Down and Bottom-Up design approaches in FPGA based system designs (8)
- (b) List the advantages of SOC (6)
- 19 (a) Explain the gate array based ASICs with neat diagram (7)
- (b) With necessary diagram illustrate antifuse technique used in programmable ASICs (7)

OR

- 20 (a) Discuss the different types of I/O cells that are used in programmable ASICs and their functions (6)
- (b) Define setup time, hold time, propagation delay and clock to output delay (8)

ECT384	DATA NETWORKS	CATEGORY	L	T	P	CREDIT
		VAC	3	1	0	4

Preamble: This course aims to provide an insight into the concepts of data communication and networking.

Prerequisite: Nil

Course Outcomes: After the completion of the course the student will be able to

CO1 K2	Explain the concepts of data communication, structure of networks and compare OSI and TCP/IP networking models
CO2 K2	Explain the responsibilities of the data link layer including framing, addressing, flow control, error control and media access control
CO3 K2	Illustrate the functions and protocols of network layer, transport layer and application layer in inter-networking
CO4 K2	Discuss congestion control techniques and Quality of Service requirements for a network

Mapping of course outcomes with program outcomes

	PO 1	PO 2	PO 3	PO 4	PO 5	PO 6	PO 7	PO 8	PO 9	PO 10	PO 11	PO 12
CO 1	3	3										2
CO 2	3	3	2									2
CO 3	3	3	2									2
CO 4	3	3										2
CO 5	3	3										2

Assessment Pattern

Bloom's Category		Continuous Assessment Tests		End Semester Examination
		1	2	
Remember	K1	20	15	20
Understand	K2	30	35	80
Apply				
Analyse				
Evaluate				
Create				

Mark distribution

Total Marks	CIE	ESE	ESE Duration
150	50	100	3 hours

Continuous Internal Evaluation Pattern:

Attendance	: 10 marks
Continuous Assessment Test (2 numbers)	: 25 marks
Assignment/Quiz/Course project	: 15 marks

End Semester Examination Pattern: There will be two parts; Part A and Part B. Part A contain 10 questions with 2 questions from each module, having 3 marks for each question. Students should answer all questions. Part B contains 2 questions from each module of which student should answer any one. Each question can have maximum 2 sub-divisions and carry 14 marks.

Course Level Assessment Questions**Course Outcome 1 (CO1): Explain the concepts of data communication, structure of networks and networking models (K2)**

1. Describe the various methods of data representation
2. Describe the different topologies of networks
3. Illustrate the functions of each layer in the OSI model

Course Outcome 2 (CO2): Explain the responsibilities of the data link layer including framing, addressing, flow control, error control and media access control (K2)

1. Describe the data link control
2. Explain the controlled access methods
3. Discuss the Pure ALOHA and Slotted ALOHA multiple access methods

Course Outcome 3 (CO3): Illustrate the functions and protocols of network layer, transport layer and application layer in inter-networking (K2)

1. Describe how logical addresses are mapped to physical address using RARP
2. Explain the application layer protocols
3. Explain the distance vector routing protocol

Course Outcome 4 (CO4): Discuss congestion control techniques and Quality of Service requirements for a network(K2)

1. Explain FIFO queuing and Priority queuing
2. Describe the characteristics attributed to a flow
3. Describe the operation of UDP

SYLLABUS

Module 1: An Overview of Data Communications and Networking

Data Communications- Components, Data representation, Data flow- Simplex, Half Duplex, Full Duplex Modes, Networks- Network criteria, Physical Structures- Point to Point Connection, Multipoint Connection, Physical Topology, Switching- Circuit Switched Networks and Datagram Networks, Categories of Networks, Interconnection of Networks, Protocols, Network models – OSI Model, Layers in the OSI Model, TCP/IP Protocol Suite

Module 2: Physical Layer and Data Link Layer

Guided Media and Unguided Transmission Media, Data Link Layer – Framing, Flow and Error Control - Stop and Wait Protocol, Sliding Window Protocol, Error Correction and Detection - Types of Errors, Redundancy, Detection vs Correction, Forward Error Correction vs Retransmission, Check Sum, Networking Devices- Hubs, Bridges, Switches

Module 3: Multiple Access, Ethernet, Wireless LANs

Multiple Access Protocols – Random Access, ALOHA, CSMA, CSMA/CD, CSMA/CA, Controlled Access, Channelization -FDMA, TDMA, CDMA, Ethernet -IEEE standards, Wireless LANs- IEEE 802.11, Bluetooth.

Module 4: Network Layer

Internetworking- Need for Network Layer, Internet as a Datagram Network, Internet as a Connectionless Network, Network Layer Logical Addressing – IPv4 and IPv6 Addressing only, Address Mapping -ARP, RARP, BOOTP, DHCP. Delivery, Forwarding, Routing Protocols - Distance Vector routing.

Module 5: Transport Layer, Congestion Control and Quality of Service

Transport layer – UDP, TCP, Congestion, Congestion Control, Quality of Service, Techniques to Improve QoS. Application Layer- FTP, Telnet, DNS, Electronic Mail

Text Book

Behrouz A Forouzan, Data Communication and Networking, 4/e, Tata McGraw Hill

Reference Books

1. Andrew S. Tanenbaum, Computer Networks, 4/e, PHI (Prentice Hall India).
2. William Stallings, Computer Networking with Internet Protocols, Prentice-Hall, 2004
3. Fred Halsall, Computer Networking and the Internet, 5/e, Pearson Education
4. Larry L Peterson and Bruce S Dave, Computer Networks – A Systems Approach, 5/e, Morgan Kaufmann

5. James F. Kurose, Keith W. Ross, Computer Networking: A Top-Down Approach, 6/e,
Pearson Education

Course Contents and Lecture Schedule

No	Topic	No. of Lectures
1	An Overview of Data Communications and Networking (9 hours)	
1.1	Components, Data representation, Data flow -Simplex, Half Duplex, Full Duplex modes	1
1.2	Networks- Network criteria, Physical Structures- Point to Point Connection, Multipoint Connection	1
1.3	Switching- Circuit Switched Networks and Datagram Networks,	2
1.4	Categories of networks, Interconnection of networks, Protocols,	1
1.5	Network models – OSI Model, Layers in the OSI model,	3
1.6	TCP/IP Protocol Suite	1
2	Physical Layer and Data Link Layer(9 hours)	
2.1	Guided Media and Unguided Transmission Media	1
2.2	Data Link Control- Framing, Flow and Error Control- Stop and Wait Protocol, Sliding Window Protocol	2
2.3	Error Detection and Correction – Types of Errors, Redundancy, Detection vs Correction, Forward Error Correction vs Retransmission	2
2.4	Check Sum	2
2.5	Networking devices -Hubs, Bridges, Switches	2
3	Multiple Access, Ethernet, Wireless LANs (8 hours)	
3.1	Random Access, ALOHA, CSMA, CSMA/CD, CSMA/CA	2
3.2	Controlled Access	1
3.3	Channelization -FDMA, TDMA, CDMA	2
3.4	Ethernet -IEEE standards, Wireless LANs- IEEE 802.11, Bluetooth	3
4	Network Layer (9 hours)	
4.1	Internetworking- Need for Network Layer, Internet as a Datagram Network, Internet as a Connectionless Network,	1
4.2	Network Layer Logical Addressing -IPv4 and IPv6 Addressing only	2
4.3	Address Mapping -ARP, RARP, BOOTP, DHCP	2
4.4	Delivery, Forwarding	2
4.5	Routing - Distance Vector routing.	2
5	Transport Layer, Congestion Control and Quality of Service (10 hours)	
5.1	UDP, TCP	3
5.2	Congestion, Congestion Control	3
5.3	Quality of Service, Techniques to Improve QoS	2
5.4	Application Layer -FTP, Telnet, DNS, Electronic Mail	2

Model Question paper**APJ ABDUL KALAM TECHNOLOGICAL UNIVERSITY**

SIXTH SEMESTER B.TECH DEGREE EXAMINATION, (Model Question Paper)

Course Code: ECT384**Course Name: DATA NETWORKS**

Max. Marks: 100

Duration: 3 Hours

PART A

Answer ALL Questions. Each Carries 3 mark.

- | | | |
|----|--|---------|
| 1 | Explain the flow of data between 2 devices | CO1,K2 |
| 2 | Illustrate the factors that determine whether a system is a LAN or a WAN | CO1, K2 |
| 3 | Explain character-oriented protocols | CO2, K2 |
| 4 | Explain how guided media differs from unguided media | CO2, K2 |
| 5 | Compare random access protocol and controlled access protocol | CO2, K2 |
| 6 | Differentiate between BSS and ESS | CO2, K2 |
| 7 | Describe the steps in ARP process | CO2, K2 |
| 8 | Differentiate between a static and dynamic routing table | CO3, K2 |
| 9 | Describe the characteristics attributed to a flow | CO4, K2 |
| 10 | Describe how congestion control is achieved using choke packet | CO4, K2 |

PART – B

Answer one question from each module; each question carries 14 marks.

Module - I

- | | | |
|----|--|---------|
| 11 | Explain the responsibilities of the layers of OSI model. | CO1, K2 |
|----|--|---------|

OR

- | | | |
|----|---|---------|
| 12 | (a) Illustrate the functioning of circuit switched networks and datagram networks | CO2, K2 |
|----|---|---------|

Module - II

- | | | |
|-----|--|---------|
| 13. | Explain how bandwidth spreading is achieved using FSSS and DSSS. | CO2, K2 |
|-----|--|---------|

OR

- | | | |
|----|--|---------|
| 14 | Illustrate the Stop and Wait Protocol. | CO3, K2 |
|----|--|---------|

Module - III

- 15 Explain the channelization protocols. CO2, K2

OR

- 16 (a) Describe the Bluetooth layers (7 marks) CO2, K2
(b) Discuss the Hidden station problem and the exposed station problem in IEEE802.11 (7 marks) CO2, K2

Module - IV

- 17 Describe mapping of logical addresses to physical addresses using ARP Protocol CO3, K2

OR

- 18 Describe the routing of packets using the distance vector routing protocol (10 marks) CO3, K2
(b) Illustrate the functionality of the network layer at the source (4 marks) CO3, K2

Module - V

- 19 Describe the ports, user datagram, checksum and operation of UDP protocol CO4, K2

OR

- 20 (a) Explain the different techniques to improve the Quality of Service (10 marks) CO4, K2
(b) Describe the services of user agent in electronic mail systems (4 marks) CO3, K2

Estd.



2014

ECT386	TOPICS IN COMPUTER VISION	CATEGORY	L	T	P	CREDIT
		VAC	3	1	0	4

Preamble: This course aims to develop the knowledge of various methods, algorithms and applications of computer vision

Prerequisite: Nil

Course Outcomes: After the completion of the course the student will be able to

CO1	Apply basic point operators and 2D transforms for digital filtering operations
CO 2	Apply various algorithms for morphological operations and binary shape analysis.
CO3	Understand the theoretical aspects of image formation and 3D camera models and vision system.
CO 4	Apply edge, corner detection methods and optical flow algorithms to locate objects in an image/video.
CO5	Analyse 3D images and motion of objects in a given scene using appropriate algorithms computer vision algorithms for real time practical applications.

Mapping of course outcomes with program outcomes

	PO 1	PO 2	PO 3	PO 4	PO 5	PO 6	PO 7	PO 8	PO 9	PO 10	PO 11	PO 12
CO 1	3	3	2		2					2	2	3
CO 2	3	3	2		2					2	2	3
CO 3	3	3	3		2					2	2	3
CO 4	3	3	3		2					2	2	3
CO 5	3	3	3		2					2	2	3

Assessment Pattern

Bloom's Category		Continuous Assessment Tests		End Semester Examination
		1	2	
Remember	K1	10	10	10
Understand	K2	10	10	20
Apply	K3	20	20	70
Analyse	K4	10	10	
Evaluate				
Create				

Mark distribution

Total Marks	CIE	ESE	ESE Duration
150	50	100	3 hours

Continuous Internal Evaluation Pattern:

Attendance	: 10 marks
Continuous Assessment Test (2 numbers)	: 25 marks
Assignment/Quiz/Course project	: 15 marks

End Semester Examination Pattern: There will be two parts; Part A and Part B. Part A contain 10 questions with 2 questions from each module, having 3 marks for each question. Students should answer all questions. Part B contains 2 questions from each module of which student should answer any one. Each question can have maximum 2 sub-divisions and carry 14 marks.

Course Level Assessment Questions

Course Outcome 1 (CO1): Apply basic point operators and 2D transforms for digital filtering operations

1. Why histogram transformations are applied in a grey scale image and what output is observed in that case.
2. Find filtered image using LP/HP/Smoothing/Median filter.
3. Describe the working principle of Homomorphic filter.

Course Outcome 2 (CO2): Apply various algorithms for morphological operations and binary shape analysis

1. List different morphological operators and describe about each one in detail.
2. To describe connected component labelling and to apply it in a given image pixel set.
3. Find 8-point connectivity and Chain code of a given image pixel diagram.

Course Outcome 3 (CO3): Understand the theoretical aspects of image formation and 3D camera models and vision system.

1. Differentiate between Monocular and binocular imaging system.
2. Compare and Contrast Orthographic and Perspective Projection methods.
3. Describe image formation and geometric transformations in 3D Camera Models.
4. Write short notes on 3D-Imaging system.
5. Briefly describe a stereo vision system.

Course Outcome 4 (CO4): Apply edge, corner detection methods and optical flow algorithms to locate objects in an image/video.

1. What is the role of edge detection and corner detection in Computer Vision applications?
2. Describe Canny's edge detection algorithm.
3. Mention the steps in Harris corner detection algorithm and explain how it is employed to detect corners in an image.
4. State with necessary mathematical steps, how Hough transform is employed for detecting lines and curves in detecting an image.

Course Outcome 5 (CO5): Analyse 3D images and motion of objects in a given scene using appropriate computer vision algorithms for real time practical applications.

1. Find Eigen values and Eigen Vectors of the following matrix

$$A = \begin{bmatrix} 8 & -8 & -2 \\ 4 & -3 & -2 \\ 3 & -4 & 1 \end{bmatrix}$$

2. Analyse a given video to track a moving object in it.
3. To detect a particular object from the background.
4. To detect signboards/ pedestrian crossings/pedestrians from a moving vehicle.
5. To classify/segment a particular set of image using CV algorithms.
6. Analyse a given image/video using Machine learning/Deep learning algorithms.
7. Use trained networks to analyse a video using ML algorithms.
8. To use Deep neural networks/CNN/YOLOvx, to analyse images/videos

SYLLABUS

Module 1

Review of image processing techniques: Filtering, Point operators-Histogram Based operators, neighbourhood operators, Thresholding - linear filtering – development of filtering masks - 2D Fourier transforms – filtering in frequency domain, Homomorphic filtering

Module 2

Mathematical Operators: Binary shape analysis: Basics of Morphological operations, structuring element, Erosion, Dilation, Opening and Closing, Hit-or-Miss Transform, Connectedness, object labelling and counting , Boundary descriptors – Chain codes.

Module 3

Camera models: Monocular and binocular imaging system, Orthographic and Perspective Projection, Image formation, geometric transformations, Camera Models (Basic idea only), 3D-Imaging system-Stereo Vision.

Module 4

Feature Detection: Edge detection – edges, lines, active contours, Split and merge, Mean shift and mode finding, Normalized cuts, Graph cuts, energy-based and Canny's methods. Corner detection, Harris corner detection algorithm, Line and curve detection, Hough transform
SIFT operators, Shape from X, Shape Matching, Structure from motion.

Module 5

Motion Analysis- Regularization theory, Optical Flow: brightness constancy equation, aperture problem, Horn-Shunck method, Lucas-Kanade method. (Analysis not required)
Object Detection and Object classification: SVM, Linear discriminant analysis, Bayes rule,

ML.

Face detection, Face Recognition, Eigen faces, 3D face models

Applications of Computer Vision: Context and scene understanding, Real Time applications:

Locating road way and road marking, locating road signs and pedestrians.

Text Books

1. E. R. Davies, Computer and Machine Vision -Theory Algorithm and Practicalities, Academic Press, 2012
2. Richard Szeliski, Computer Vision: Algorithms and Applications, ISBN 978-1-84882-935-0, Springer 2011.
3. David Forsyth and Jean Ponce, Computer Vision: A Modern Approach, Pearson India, 2002.

Reference Books

1. Goodfellow, Bengio, and Courville, Deep Learning, MIT Press, 2006.
2. Daniel Lelis Baggio, Khvedchenia Ievgen, Shervin Emam, David Millan Escriva, Naureen Mahmoo, Jason Saragi, Roy Shilkrot, Mastering Open CV with Practical Computer Vision Projects, Packt Publishing Limited, 2012
3. Simon J D Prince, Computer Vision: Models, Learning, and Inference, Cambridge University Press, 2012.
4. R. J. Schalkoff, Digital Image Processing and Computer Vision, John Wiley, 2004.

Course Contents and Lecture Schedule

No.	Topic	No. of Lectures
1	Introduction	
1.1	Review of image processing techniques: filtering.	2
1.2	Point operators- Histogram, neighbourhood operators, thresholding– development of filtering masks	3
1.3	2D Fourier transforms – filtering in frequency domain, homomorphic filtering	3
2	Mathematical Operators:	
2.1	Basics of Morphological operations , structuring element	2
2.2	Binary shape analysis : Erosion, Dilation, Opening and Closing, Hit-or-Miss Transform	2
2.3	Connectedness, object labelling and counting	2
2.4	Boundary descriptors –Chain Codes.	2
3	Camera models	
3.1	Monocular and binocular imaging system	2
3.2	Orthographic & Perspective Projection	2
3.3	Image formation, geometric transformations, camera Models(Basic idea only)	3
3.4	3D-Imaging system-Stereo Vision	2
4	Feature Detection:	
4.1	Edge detection – edges, lines, active contours, Split and merge, Mean shift and mode finding, Normalized cuts, Graph cuts, energy-based	4

	and Canny's methods.	
4.2	Corner detection, Harris corner detection algorithm, Line and curve detection, Hough transform	3
4.3	SIFT operators, Shape from X, Shape Matching	3
5	Motion Analysis	
5.1	Motion Analysis- Regularization theory, Optical Flow: brightness constancy equation, aperture problem, Horn-Shunck method, Lucas-Kanade method (Analysis not required)	3
5.2	Object Detection and Object classification: SVM, Linear discriminant analysis, Bayes rule, maximum likelihood, Face detection, Face Recognition, Eigen faces, 3D face models	4
5.3	Applications of Computer Vision: Context and scene understanding, Real Time applications: Locating road way and road marking, locating road signs and pedestrians	3

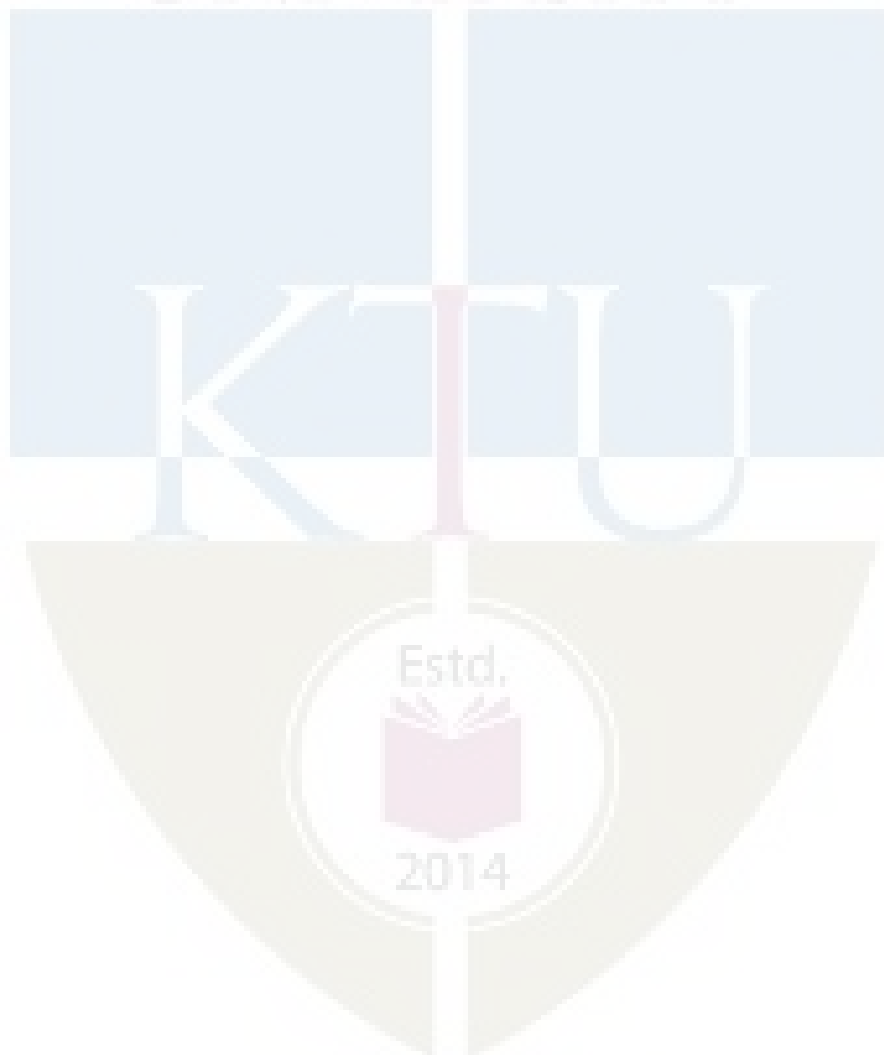

Simulation Assignments

ELECTRONICS & COMMUNICATION ENGINEERING

The following simulations can be done in OpenCV/SciLab/ MatLab

1. Design and implementation of basic digital filters.
2. Apply thresholding operations in a digital image.
3. Apply point operators in an image – averaging/smoothing, 2D - masks(3 types),
4. Apply morphological operations in a selected image like fingerprint/ archaeological scripts.
5. Implement filters in 2D-frequency domain using Gaussian/Homomorphic filters in a particular satellite image or forensic image.
6. Write algorithms for connected component labelling in a given image pixel set.
7. Detect a coin/ball against the background using background subtraction and with appropriate edge detection algorithms.
8. Locate corners of a particular image like boxes/ building/TV screen etc
9. Write a program to implement brightness constancy equation.
10. Analyse the optical flow of a given video using Horn-Schunk method or/and Lucas-Kannade method/s.
11. Use PCA for dimensionality reduction in detecting faces using Eigen values.
12. Implement SVM/LDA for a practical application.
13. Create an attendance system by implementing face recognition method, among a set of students.
14. With OpenCV library, implement real time scene analysis for traffic regulation. (cases such as detecting road signs/ pedestrians/track a particular vehicle/ detect traffic lights/detect number plate of a vehicle/ detect accidents/ accident scene analysis etc., etc.).
15. Use ML/DL algorithms to implement object detection/identification/classification, with trained neural networks for applications in medical/agricultural/sports fields.

2014

Model Question paper

ELECTRONICS & COMMUNICATION ENGINEERING

APJ ABDUL KALAM TECHNOLOGICAL UNIVERSITY

SIXTH SEMESTER B.TECH DEGREE EXAMINATION, (Model Question Paper)

Course Code: EC386

Course Name: TOPICS IN COMPUTER VISION

(Minor)

Max. Marks: 100

Duration: 3 Hours

PART A

Answer ALL Questions. Each carries 3 marks.

1	Compare and Contrast DoG and LoG.	K1									
2	An image is convolved with the matrix given below. Express analytically the relation between original and modified image. <div style="text-align: center;"><table border="1"><tbody><tr><td>•0</td><td>•0</td><td>•0</td></tr><tr><td>•0</td><td>•0</td><td>•1</td></tr><tr><td>•0</td><td>•0</td><td>•0</td></tr></tbody></table></div>	•0	•0	•0	•0	•0	•1	•0	•0	•0	K2
•0	•0	•0									
•0	•0	•1									
•0	•0	•0									
3	List any three computer vision applications of object labeling and counting.	K2									
4	Describe steps in identifying connected components in 4-connectivity and 8-connectivity cases.	K2									
5	Describe the working principle of pin- hole camera	K2									
6	Compare and contrast perspective and orthographic projection.	K2									
7	Mention the concept of identifying structure from motion.	K2									
8	Illustrate how graph cut method is employed for edge detection	K2									
9	Define eigen values and eigen vectors.	K2									
10	Differentiate between SVM and LDA.	K2									
	PART – B Answer one question from each module; each question carries 14 marks.										
	Module - I										
11 a	What is thresholding? Briefly describe different methods of thresholding.	(6) CO1 K1									

11 b.	Apply 2D-DFT on the given image pixel values $\begin{bmatrix} 1 & 2 & 2 & 0 \\ 0 & 1 & 3 & 1 \\ 0 & 1 & 2 & 1 \\ 1 & 2 & 2 & -1 \end{bmatrix}$	(8) CO1 K3
OR		
12 a	Describe how histogram transformations are applied on a grey scale image and explain what output is observed in each case.	(8) CO1 K3
12 b.	Describe the working principle of Homomorphic filter, with different mathematical steps involved.	(6) CO1 K2
Module - II		
13a	An image A, and a structuring element B are given. Apply B on A, to find resultant images after the dilation and erosion process. Origin is given as 'O'; and note that it is not part of the structuring element. $A = \begin{bmatrix} & & & & & & \\ & 1 & 1 & 1 & & & \\ & 1 & & 1 & & & \\ & 1 & & 1 & 1 & & \\ & & & & 1 & 1 & \\ O & & & & & & \end{bmatrix}$ $B = \begin{bmatrix} 1 & O & 1 \end{bmatrix}$	(8) CO2 K3
13 b.	Using Hoshen–Kopelman algorithm, assign connected component labelling for the given image in the diagram below. 	(6) CO2 K3

OR

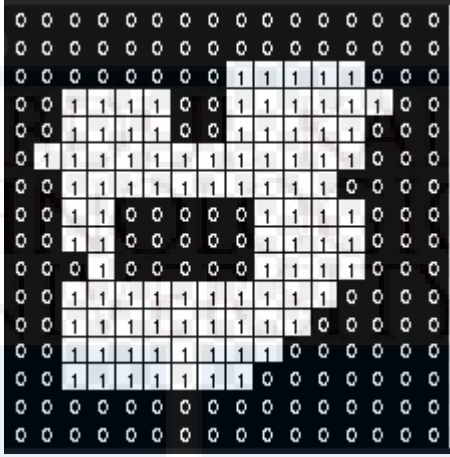
14a	<p>Apply Hit-or-Miss transform on the given binary image to detect right angle convex corners from left-top to right-bottom.</p> 	(8) CO2 K3																																																								
14b.	<table border="1" data-bbox="604 887 1083 1402"> <tr><td></td><td></td><td></td><td></td><td></td><td></td><td></td></tr> <tr><td></td><td></td><td>x</td><td>x</td><td>x</td><td></td><td></td></tr> <tr><td></td><td>x</td><td></td><td></td><td></td><td>x</td><td></td></tr> <tr><td></td><td></td><td>x</td><td></td><td>x</td><td></td><td></td></tr> <tr><td></td><td></td><td>x</td><td></td><td></td><td>x</td><td></td></tr> <tr><td></td><td></td><td></td><td>x</td><td>x</td><td></td><td></td></tr> <tr><td></td><td></td><td></td><td></td><td></td><td></td><td></td></tr> <tr><td></td><td></td><td></td><td></td><td></td><td></td><td></td></tr> </table> <p>For the given image grid, find out the 8-chain Freeman Code. Also write down the chain number of the code.</p>										x	x	x				x				x				x		x					x			x					x	x																	(6) CO2 K3
		x	x	x																																																						
	x				x																																																					
		x		x																																																						
		x			x																																																					
			x	x																																																						
15	Describe image formation and geometric transformations in 3D Camera Models.	(14) CO3 K2																																																								
OR																																																										
16a	Briefly describe a stereo vision system.	(7) CO3 K2																																																								
16 b	Elucidate on 3D-Imaging Camera system.	(7) CO3 K2																																																								

Module - IV
ELECTRONICS & COMMUNICATION ENGINEERING

17a	With the help of a general algorithm, narrate how Hough Transform can be employed for interest point detection.	(6) CO4 K3
17 b	Unveil different steps involved in Harris corner detection algorithm and explain how it is employed to detect corners in an image	(8) CO4 K3
OR		
18 a.	Apply Sobel and Prewitt masks on the given image grids and compute Gx and Gy gradients of the images.	(6) CO4 K3
18 b.	Referring to Canny's algorithm, describe how it is employed to detect edges of an image.	(8) CO4 K3
Module - V		
19 a	Derive brightness constancy equation.	(6) CO5 K3
19 b	Describe with algorithmic steps, the Horn-Shunk method used for the estimation of optical flow.	(8) CO5 K3
20 a	Illustrate the concept of dimensionality reduction using Principal Component Analysis (PCA) with all mathematical steps involved.	(7) CO5 K3
20b.	With the help of a flow chart, illustrate an in-vehicle vision system, for locating roadways and pedestrians, as a practical application of computer vision.	(7) CO5 K3

APJ ABDUL KALAM
TECHNOLOGICAL
UNIVERSITY

SEMESTER VI

HONOURS



ECT394	ELECTRONIC DESIGN AUTOMATION	CATEGORY	L	T	P	CREDIT
		VAC	3	1	0	4

Preamble: The course aims to introduce principles behind advanced methods in automation of electronic design.

Prerequisites: Nil

Course Outcomes: After the completion of the course the student will be able to

CO 1	Apply Search Algorithms and Shortest Path Algorithms to find various graph solutions.
CO 2	Outline VLSI Design Flow and Design Styles and apply partitioning algorithms on graphs representing netlist.
CO 3	Illustrate Design Layout Rules and apply different algorithms for layout compaction.
CO 4	Make use of various algorithms to solve placement and floorplan problems.
CO 5	Utilise different algorithms to solve routing problems.

Mapping of course outcomes with program outcomes

	PO1	PO2	PO3	PO4	PO5	PO6	PO7	PO8	PO9	PO 10	PO 11	PO 12
CO 1	3	2										3
CO 2	3	2										3
CO 3	3	2										3
CO 4	3	2										3
CO 5	3	2										3

Assessment Pattern

Bloom's Category	Continuous Assessment Tests		End Semester Examination
	1	2	
Remember			
Understand	K2	30	30
Apply	K3	20	20
Analyse			
Evaluate			
Create			

Mark distribution

Total Marks	CIE	ESE	ESE Duration
150	50	100	3 hours

Continuous Internal Evaluation Pattern:

Attendance	: 10 marks
Continuous Assessment Test (2 numbers)	: 25 marks
Assignment/Quiz/Course project	: 15 marks

End Semester Examination Pattern: There will be two parts; Part A and Part B. Part A contain 10 questions with 2 questions from each module, having 3 marks for each question. Students should answer all questions. Part B contains 2 questions from each module of which student should answer any one. Each question can have maximum 2 sub-divisions and carry 14marks.

CO Assessment Questions**CO1: Apply Search Algorithms and Shortest Path Algorithms to find various graph solutions**

1. Represent the following graph by Adjacency Matrix.
2. List a DFS ordering of vertices for the graph shown in question 1 with starting node as H.
3. Perform topological sort on the graph in question 1 and order the vertices with Starting node is H.

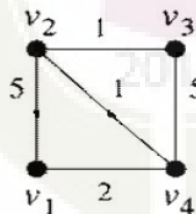
CO2: Outline VLSI Design Flow and Design Styles and apply partitioning algorithms on graphs representing netlist.

1. Perform KL partitioning on the above graph. You may assume any initial partition of your choice.
2. Draw the flowchart of VLSI Design Flow and explain the different stages

CO3: Illustrate Design Layout Rules and apply different algorithms for layout compaction.

1. For the following graph, find the longest path to all other vertices from vertex v_0 , using Bellman-Ford Algorithm.

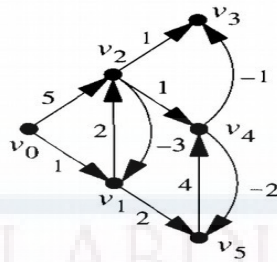

2. Use the Longest Path Algorithm to find the longest path from vertex A, in the following graph

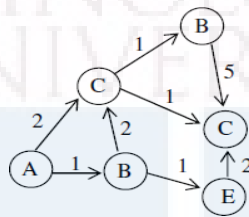

CO4: Make use of various algorithms to solve placement and floorplan problems.

1. Consider the following floorplan.

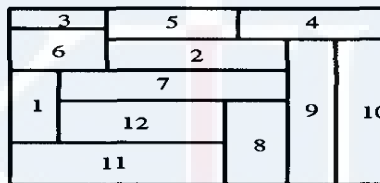

Draw the floorplan slicing tree and the polar graphs of the above floorplan.

CO5: Utilise different algorithms to solve routing problems.

1. Perform LEE's Algorithm to find shortest path from S to T. Cells marked O indicate obstructions.

	T				
O			O	O	O
		O			
			O	S	

2. Draw Horizontal and Vertical Constraint Graph for the following Channel Routing

3.

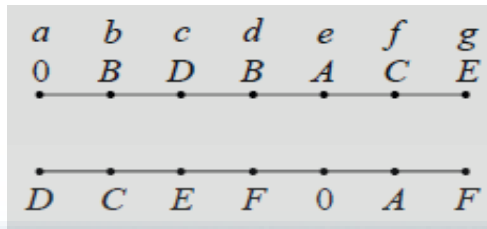

Model Question Paper

**APJ Abdul Kalam Technological University
Sixth Semester B Tech Degree Examination**

Branch: Electronics and Communication

Course: ECT394 Electronic Design Automation

Time: 3 Hrs

Max. Marks: 100

PART A

Answer All Questions

1. Define the following giving an example each (3) (K2)
(a) Degree of a vertex (b) Subgraph (c) Directed Acyclic Graph (DAG)
2. Represent the following graph by Adjacency Matrix. (3) (K2)

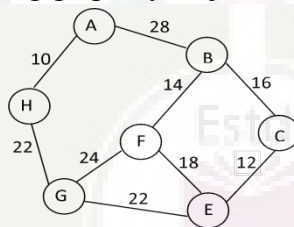

3. Write short note on (a) Full Custom Design (b) Standard Cell Design (3) (K1)
4. Explain any three parameters based on which Partitioning is performed. (3) (K1)
5. What are the minimum distance rules in Design Rules for layout? (3) (K1)
6. Write inequality expressions for minimum distance and maximum distance constraints between two rectangular edges. (3) (K1)
7. For the following placement, calculate the wirelength by (a) Half Perimeter Method (b) Maximum Rectilinear Tree Method (3) (K3)

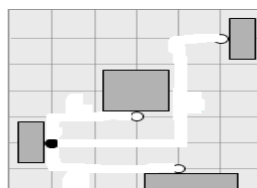

8. Represent the following floor plan using the Pair approach. (3) (K3)



9. How is Global Routing different from Detailed Routing? (3) (K1)
 10. Define the following terms (a) Reserved Layer Model (b) Channel (c) Dogleg (3)(K1)

PART B

Answer one question from each module. Each question carries 14 marks.

11. (A) List a DFS ordering of vertices for the graph shown in question 2. (7) (K3)
 Starting node is H.
 (B) Perform topological sort on the graph and order the vertices. (7) (K3)
 Starting node is H.

OR

12. (A) List a BFS ordering of vertices for the graph shown in question 2. (10)(K3)
 Starting node is H.
 (B) Give an application related to VLSI of BFS. (4) (K2)

13. Draw the flowchart of VLSI Design Flow and explain the different stages. (14) (K1)

OR

14. Perform KL partitioning on the following graph. You may assume any initial partition of your choice. (14)(K3)

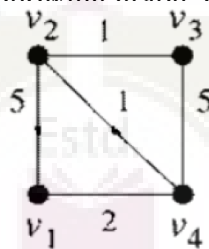

15. (A) For the following graph, find the longest path to all other vertices from vertex v_0 , using Bellman-Ford Algorithm. (10) (K3)

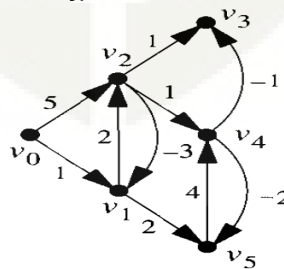

- (B) What is the time complexity of Liao-Wong and Bellman-Ford Algorithms? (4) (K2)

OR

16. (A) Use the Longest Path Algorithm to find the longest path from vertex A, (8) (K3) in the following graph.

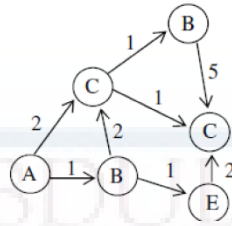

(B) What is the limitation of Longest Path Algorithm? (2) (K1)

(C) List two methods to find shortest path using Longest Path Algorithm (4) (K2)

17. Consider the following floorplan.

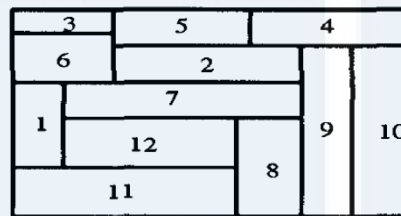

(A) Draw the floorplan slicing tree of the above floorplan. (6) (K3)

(B) Draw the polar graphs of above floorplan. (8) (K3)

OR

18. Given: Placement P with two fixed points $p_1 (100,175)$ and $p_2 (200,225)$, (14) (K3) three free blocks $a-c$ and four nets N_1-N_4 . $N_1 (P_1,a)$ $N_2 (a,b)$ $N_3 (b,c)$ $N_4 (c,P_2)$. Find the coordinates of blocks (x_a, y_a) , (x_b, y_b) and (x_c, y_c) .

19. Perform LEE's Algorithm to find shortest path from S to T. Cells marked O indicate obstructions. (14) (K3)

	T					
O			O	O	O	
		O				
			O	S		

OR

20. Draw Horizontal and Vertical Constraint Graph for the following Channel (14) (K3) Routing.

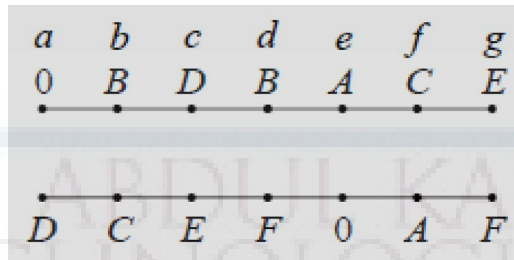

Simulation Assignments

1. Develop C code for all algorithms in Module 1, 2 and 3.
2. A digital circuit can be taken through all steps of VLSI Design Flow (ie. From HDL to Layout) using any standard tool set from Cadence, Synopsis or Mentor Graphics or similar tools

Syllabus

Module 1: Graph Terminology, Search Algorithms and Shortest Path Algorithms:

Graph Terminology: Basic graph theory terminology, Data structures for representation of

Graphs Search Algorithms: Breadth First Search, Depth First Search, Topological Sort

Shortest Path Algorithms: Dijkstra's Shortest-Path Algorithm for single pair shortest path, Floyd Warshall Algorithm for all pair shortest path

Module 2: Design Automation and Partitioning Algorithms:

Design Automation: VLSI Design Flow, VLSI Design Styles

Partitioning: Levels of Partitioning, Parameters for Partitioning, Classification of Partitioning Algorithms, Kernighan-Lin Algorithm, Fiduccia-Mattheyses Algorithm, Simulated Annealing

Module 3: Layout Compaction:

Layout: Layout Layers and Design Rules, Physical Design Optimizations

Compaction: Applications of Compaction, Informal Problem Formulation, Graph Theoretical Formulation, Maximum Distance Constraints, Longest Path algorithm for DAG, Longest path in graph with cycles, Liao-Wong Algorithm, Bellman-Ford Algorithm.

Module 4: Placement and Floorplanning:

Placement: Optimization Objectives, Wirelength Estimation, Weighted Wirelength, Maximum Cut Size, Wire Density

Placement Algorithms: Quadratic Placement

Floorplanning: Optimization Objectives, Slicing Floorplan, Non-Slicing Floorplan

Floorplan Representations: Constraint Graph, Sequence Pair

Floorplan Algorithms: Minimum Area Algorithm

Module 5: Global Routing and Detailed Routing:

Global Routing: Terminology and Definitions, Optimization Goals, Representation of Routing Regions

Maze Routing Algorithms: Lee's Algorithm, Hadlock Algorithm

Detailed Routing: Horizontal and Vertical Constraint Graph

Channel Routing Algorithms: Left-Edge algorithm

Text Books

1. Jin Hu, Jens Lienig, Igor L. Markov, Andrew B. Kahng, VLSI Physical Design: From Graph Partitioning to Timing Closure, Springer, 2011th edition.
2. Gerez, Sabih H., "Algorithms for VLSI Design Automation", John Wiley & Sons, 2006.
3. Sherwani, Naveed A., "Algorithms for VLSI Physical Design Automation", Kluwer Academic Publishers, 1999.

Reference Books

1. Sadiq M. Sait and H. Youssef, "VLSI Physical Design Automation: Theory and Practice", World Scientific, 1999.
2. Cormen, Thomas H., Charles E. Leiserson, and Ronald L. Rivest. "Introduction to Algorithms." The MIT Press, 3rd edition, 2009.

Course Contents and Lecture Schedule

No.	Topic	Number of Lectures
1	Graph Terminology, Search Algorithms and Shortest Path Algorithms:	
1.1	Graph Terminology: Basic graph theory terminology, Data structures for representation of Graphs	2
1.2	Search Algorithms: Breadth First Search, Depth First Search, Topological Sort	2
1.3	Shortest Path Algorithms: Dijkstra's Shortest-Path Algorithm for single pair shortest path, Floyd Warshall Algorithm for all pair shortest path	4
2	Design Automation and Partitioning Algorithms:	
2.1	Design Automation: VLSI Design Flow, VLSI Design Styles	3
2.2	Partitioning: Levels of Partitioning, Parameters for Partitioning, Classification of Partitioning Algorithms	1
2.3	Kernighan-Lin Algorithm, Fiduccia-Mattheyses Algorithm, Simulated Annealing	5
3	Layout Compaction:	

3.1	Layout: Layout Layers and Design Rules, Physical Design Optimizations	1
3.2	Compaction: Applications of Compaction, Informal Problem Formulation, Graph Theoretical Formulation, Maximum Distance Constraints	1
3.3	Longest Path algorithm for DAG, Longest path in graph with cycles, Liao-Wong Algorithm, Bellman-Ford Algorithm.	7
4	Placement and Floorplanning:	
4.1	Placement: Optimization Objectives, Wirelength Estimation, Weighted Wirelength, Maximum Cut Size, Wire Density	3
4.2	Placement Algorithms: Quadratic Placement	2
4.3	Floorplanning: Optimization Objectives, Slicing Floorplan, Non-Slicing Floorplan Floorplan Representations: Constraint Graph, Sequence Pair	3
4.4	Floorplan Algorithms: Minimum Area Algorithm	3
5	Global Routing and Detailed Routing:	
5.1	Global Routing: Terminology and Definitions, Optimization Goals, Representation of Routing Regions	1
5.2	Maze Routing Algorithms: Lee's Algorithm, Hadlock Algorithm	2
5.3	Detailed Routing: Horizontal and Vertical Constraint Graph	3
5.4	Channel Routing Algorithms: Left-Edge algorithm	2



ECT396	MIMO AND MULTIUSER COMMUNICATION SYSTEMS	CATEGORY	L	T	P	CREDIT
		VAC	3	1	0	4

Preamble: MIMO systems are rising attention of the academic community and industry because of their potential to increase to capacity and diversity gain proportionally with the number of antennas. OFDM is a promising solution to mitigate the effect of inter symbol interference (ISI) and multipath fading. MIMO OFDM is an attractive air interface solution for multiuser communication and effectively deployed in wireless local area networks, fifth Generation (5G) wireless cellular standards.

Prerequisite: MAT 204 Probability and Random Process, ECT 305 Analog and Digital Communication.

Course Outcomes: At the end of the course, the students will be able to

CO 1	Describe digital communication over multipath channels
CO 2	Analyse the performance of multiuser communication techniques over generalized fading channel.
CO 3	Describe the concept of MIMO systems and determine the capacity of MIMO channel
CO 4	Introduce OFDM and associated timing and frequency synchronization in MIMO receiver
CO 5	To explain the theory of MIMO multiuser communication systems.

Mapping of course outcomes with program outcomes

	PO 1	PO 2	PO 3	PO 4	PO 5	PO 6	PO 7	PO 8	PO 9	PO 10	PO 11	PO 12
CO 1	3		2									
CO 2	3	3	2									
CO 3	3											
CO 4	3		2									
CO 5	3											

Assessment Pattern

Bloom's Category	Continuous Assessment Tests		End Semester Examination
	1	2	
Remember			
Understand	K2	30	30
Apply	K3	20	20
Analyse			
Evaluate			
Create			

Mark distribution

Total Marks	CIE	ESE	ESE Duration
150	50	100	3 hours

Continuous Internal Evaluation Pattern:

Attendance : 10 marks

Continuous Assessment Test (2 numbers) : 25 marks

Assignment/Quiz/Course project : 15 marks

End Semester Examination Pattern: There will be two parts; Part A and Part B. Part A contain 10 questions with 2 questions from each module, having 3 marks for each question. Students should answer all questions. Part B contains 2 questions from each module of which student should answer any one. Each question can have maximum 2 sub-divisions and carry 14 marks.

Course Level Assessment Questions**Course Outcome 1 (CO1)**

1. Define doppler spread.
2. Distinguish between flat fading and frequency selective fading
3. Derive the relation between Power spectra and channel correlation.

Course Outcome 2 (CO2)

1. State and infer the capacity of different multiple access techniques.
2. Describe CDMA signal and channel model.
3. Derive the autocorrelation matrix of CDMA multiuser Asynchronous transmission.

Course Outcome 3 (CO3)

1. Determine the channel capacity of SISO and MIMO systems.
2. Determine the channel capacity of MIMO system when CSI is known to the transmitter side.
3. Compare the detection performance of MLSE and ZF equalizer.

Course Outcome 4 (CO4)

1. Describe FFT based implementation of OFDM.
2. Analyze the effect of symbol time offset in OFDM systems.
3. Describe the synchronization using cyclic prefix to OFDM systems.

Course Outcome 5 (CO5)

1. Distinguish between array gain and diversity gain.
2. Define spatial multiplexing.
3. Draw the general block diagram of MIMO system.
4. Write the motivation behind using multiuser communication in wireless scenario.

MODEL QUESTION PAPER

**APJ ABDULKALAM TECHNOLOGICAL
UNIVERSITY MODEL QUESTION PAPER
ECT396 MIMO AND MLIUSER COMMUNICATION SYSTEMS**

Time: 3 hours**Max.Marks:100****PART A**

Answer *all* questions. Each question carries *3marks*.

1. Distinguish between frequency selective and frequency non selective fading.
2. Define Doppler spread.
3. State the capacity of FDMA
4. Mention the applications of TDMA and CDMA
5. Draw the channel model for SIMO system.
6. Explain the significance of Ergodic capacity.
7. What are the gains available in MIMO systems?
8. Define spatial multiplexing.
9. Define inter symbol interference.
10. Write short notes on OFDMA.

PART B

Answer *anyone* question from each module. Each question carries *14marks*.

MODULE I

11. (a) Draw and explain the Tapped delay line channel model used in frequency selective slowly fading channel . (10 marks)
(b) Distinguish between fast and slow fading. (4 marks)
12. A multipath fading channel has a multipath spread of 1s and a Doppler spread of 0.01 Hz. The total channel bandwidth at band pass available for signal transmission is 10 Hz. To mitigate the effect of ISI select the pulse duration 10s.
 - (a) Calculate the coherence bandwidth and coherence time. (5 marks)
 - (b) Is the channel is frequency selective or not? Justify your answer. (5 marks)
 - (c) Is the channel fading slowly or rapidly? Justify your answer. (4 marks)

MODULE II

13. (a) Briefly describe FDMA and TDMA. (8 marks)
(b) State and infer the capacity of single user CDMA detection scheme. (6 marks)
14. (a) With the aid of Gaussian PDF derive the Maximum Likelihood (ML) criteria of CDMA decorrelation receiver. (10 marks)

MODULE II

15. (a) Determine the channel capacity of MIMO system when CSI is known to the transmitter side and when CSI is not available at transmitter side. (10 marks)
 (b) Distinguish between outage probability and outage capacity. (4 marks)
16. (a) State the significance of Ergodic capacity. (5 marks)
 (b) Determine the capacity of deterministic MIMO channel assuming AWGN capacity. (9 marks)

MODULE IV

17. (a) What is sphere decoding? (4 marks)
 (b) Compare the detection performance of ZF and MMSE signal detection techniques in MIMO receiver. (10 marks)
18. (a) Compare array gain and diversity gain. (4 marks)
 (b) Briefly describe receive and transmit antenna diversity. (10 marks)

MODULE V

19. (a) Consider a transmitter sends digital information by use of M signal waveforms $\{s_m(t), m = 1, 2, \dots, M\}$ over an AWGN channel. The channel is assumed to be corrupt the signal by the addition of white Gaussian noise. Write down the expression for received signal in the interval $0 \leq t \leq T$ and draw the model for received signal passed through the channel. (4 marks)
 (b) Describe the FFT based implementation of OFDM system. (10 marks)
20. (a) State and prove Nyquist condition for zero ISI. (4 marks)
 (b) Describe the synchronization technique using cyclic prefix in OFDM systems. (10 marks)

SYLLABUS**Module 1 – Digital Communication over Fading Multipath Channels**

Multipath fading, Coherence time, Coherence bandwidth, Doppler spread, Characterization of fading multipath channels, Statistical model for fading channels (Rayleigh and Rice distribution), Relation between channel correlation and Power spectral density, Signal characteristics on the choice of channel model (frequency selective and frequency nonselective fading), Frequency nonselective slowly fading channel, Frequency selective slowly fading channel, Fast fading, Rake receiver.

Module 2 – Multiuser Communications

Types of multiple access techniques (FDMA, TDMA and CDMA), Capacity of multiple access methods (*Inference only*). Single user detection, Multiuser detection, CDMA signal and channel model, CDMA optimum receiver (Synchronous transmission, Asynchronous transmission), Suboptimum detectors (Single user detector and Decorrelation receiver). Practical applications of multiple access techniques.

Module 3 – MIMO System

Signal and channel model for SISO,SIMO,MISO and MIMO, Capacity of frequency flat deterministic MIMO channel (both channel unknown and known to the transmitter), SIMO channel capacity, MISO channel capacity, Capacity of random MIMO channels, Ergodic capacity, Outage capacity, Capacity of frequency selective MIMO channels (both channel unknown and known to the transmitter)

Module 4 – Diversity and Receiver

Array gain, Diversity gain, Spatial multiplexing, Receive antenna diversity, Transmit antenna diversity, SISO receiver (MLSE, ZF and Decision feedback equalizer), SIMO receiver, MIMO receiver (both Optimal and suboptimal), Sphere decoding.

Module 5 – OFDM

Review of AWGN channel and band limited ISI channel, Introduction to multicarrier systems, FFT based multicarrier system, Mitigation of subcarrier fading, SISO-OFDM, MIMO-OFDM, Coarse time synchronization, Fine time synchronization, Coarse frequency synchronization, OFDMA, Wireless standards (WiMAX, and 3GPP LTE)

Note: Mathematical model and analysis to be covered for the entire topic.

Text Books

1. “Digital Communications”, John G Proakis, 4/e, McGraw-Hill.
2. “Fundamentals of Wireless Communications”, David Tse and Pramod Viswanath, Cambridge University Press, 2005.
3. “Introduction to Space Time Wireless Communications”, A Paulraj, Nabar and D Gore Cambridge University Press, 2003.
4. “MIMO OFDM Wireless Communications with MATLAB”, Y S Cho, J Kim, Won Yong Yang, Chung G Kang, John Wiley& sons private Ltd, 2010.

Reference Books

5. “Space Time Block Coding for Wireless Communications”, Erik G Larsson, Cambridge University Press, 2003.
6. “MIMO Wireless Communications”, E Biglieri, R Calderbank, A Constantinides, A Goldsmith, A Paulraj, Cambridge University Press.
7. “Digital Communications”, Simon Haykin, John Wiley & Sons Pvt Ltd. 2001.
“Wireless Communications” Andrea Goldsmith, Cambridge University Press 2005

Course Contents and Lecture Schedule

No	Topic	No. of Lectures
1	Digital Communication over Fading Multipath Channels	
1.1	Multipath fading, Coherence time, Coherence bandwidth, Doppler spread	1
1.2	Characterization of fading multipath channels, Statistical model for fading channels (Rayleigh and Rice distribution), Relation between channel correlation and Power spectral density	4
1.3	Signal characteristics on the choice of channel model (frequency selective and frequency nonselective fading), Frequency nonselective slowly fading channel, Frequency selective slowly fading channel	3
1.4	Fast fading, Rake receiver	2
2	Multisuser Communications	
2.1	Types of multiple access techniques (FDMA, TDMA and CDMA), Capacity of multiple access methods (without proof, Inference only).	2
2.2	Single user detection, Multisuser detection	1
2.3	CDMA signal and channel model, CDMA optimum receiver (Synchronous transmission, Asynchronous transmission),	2
2.4	Suboptimum detectors (Single user detector and Decorrelation receiver).	1
2.5	Practical applications of multiple access techniques.	1
3	MIMO System	
3.1	Signal and channel model for SISO, SIMO, MISO and MIMO	2
3.2	Capacity of frequency flat deterministic MIMO channel (both channel unknown and known to the transmitter), SIMO channel capacity, MISO channel capacity	4
3.3	Capacity of random MIMO channels	1
3.4	Ergodic capacity, Outage capacity, Capacity of frequency selective MIMO channels (both channel unknown and known to the transmitter)	2
4	Diversity and Receiver	
4.1	Array gain, Diversity gain, Spatial multiplexing.	1
4.2	Receive antenna diversity, Transmit antenna diversity	1
4.3	SISO receiver (MLSE, ZF and Decision feedback equalizer)	2
4.4	SIMO receiver	1
4.5	MIMO receiver (both Optimal and suboptimal), Sphere decoding.	3
5	OFDM	
5.1	Review of AWGN channel and band limited ISI channel	1
5.2	Introduction to multicarrier systems, FFT based multicarrier system	2

5.3	Mitigation of subcarrier fading, SISO-OFDM, MIMO-OFDM	2
5.4	Coarse time synchronization, Fine time synchronization, Coarse frequency synchronization	3
5.5	OFDMA, Wireless standards (WiMAX, and 3GPP LTE)	2

SIMULATION ASSIGNMENTS

The following simulation assignments can be done with Python/ MATLAB/ SCILAB /LabVIEW

1 Frequency Non-selective Slowly Fading Channel

- Generate binary PSK and binary FSK signals for transmission over a frequency non-selective slowly fading channel.
- Obtain the received equivalent lowpass signal of the transmitted signal using equation 13.3-1. Also plot the BER-SNR curve for coherent binary PSK and FSK detector using equations 13.3-2 and 13.3-3 respectively in page 846 in *Digital Communications by John G Proakis, 4/e*, for fixed attenuation value, α fixed and follows Rayleigh distribution case.
- Plot the BER-SNR curve for coherent binary PSK and FSK detector using equations 13.3-13 in page 848 in *Digital Communications by John G Proakis, 4/e* for α following Rayleigh distribution.
- Compare the BER-SNR curve for AWGN and Rayleigh fading channel.

2 CDMA Transmitter and Receiver

- Create 2 random binary sequence of 100 bit each as data blocks of 2 users.
- Generate the composite transmitted signal, $s(t)$ for 3 users using equations 16.3-7 in page 1037 in *Digital Communications by John G Proakis, 4/e*.
- Add AWGN of different variances to generate the received signal, $r(t)$.
- Realize the optimum multiuser receiver for synchronous transmission shown in Fig. 16.3-1 in page 1040 in *Digital Communications by John G Proakis, 4/e*
- Observe the decoded bits for AWGN of different variances.

3 Capacity of MIMO Channels

- Create MIMO channel transfer matrix, H of size $M_R \times M_T$, where M_R and M_T represents number of receive and transmit antennas respectively.
- Compute the capacity of SISO, SIMO, MISO and MIMO channels for different values of SNR using equations in page 138 in *Introduction to Space Time Wireless Communications by A Paulraj, Nabar and D Gore*.

- Plot Capacity-SNR curve for different channels and compare.

4 Performance of SISO Receiver

- Realize the signal model for SISO frequency selective fading channel given in equation 7.5 in page 138 in *Introduction to Space Time Wireless Communications* by A Paulraj, Nabar and D Gore.
- Transmit a sequence of symbols based on signal model.
- Obtain the estimated symbol sequence using MLSE receiver based on equation 7.8 in page 139 in *Introduction to Space Time Wireless Communications* by A Paulraj, Nabar and D Gore.

5 OFDM Communication System

- Realize the block diagram of OFDM communication system shown in Fig 11.2-4 in page 750 in *Digital Communications* by John G Proakis, 4/e.
- Create a random bit vector of arbitrary length. Realize the OFDM transmitter by mapping the message bits into a sequence of QAM symbols and convert it into N parallel streams.
- Each of N symbols from serial-to-parallel (S/P) conversion is carried out by the different subcarrier. Realize the multicarrier modulation by computing IFFT.
- Add cyclic prefix, realize parallel to serial converter and DAC to generate the transmitted signal.

Transmit the signal through a fading channel.

- Realize OFDM receiver by first removing cyclic prefix followed by serial to parallel conversion, FFT computation, signal detection and parallel to serial conversion.
- Plot the BER-SNR curve and analyse.

ECT398	DETECTION AND ESTIMATION THEORY	CATEGORY	L	T	P	CREDIT
		VAC	3	1	0	4

Preamble: This course aims to impart the fundamentals of detection and estimation theory in engineering applications

Prerequisite: MAT 101 Linear Algebra and Calculus

MAT 204 Probability, Random Process, and Numerical Methods

ECT 204 Signals and Systems

Course Outcomes: After the completion of the course the student will be able to

CO1 K2	Understand the fundamentals of statistical detection and estimation principles used in various engineering problems.
CO2 K3	Apply various types of statistical decision rules in engineering applications.
CO3 K3	Apply different types of estimation algorithms in engineering applications.

Mapping of course outcomes with program outcomes

	PO1	PO2	PO3	PO4	PO5	PO6	PO7	PO8	PO9	PO10	PO11	PO12
CO 1	3	3										2
CO 2	3	3										2
CO 3	3	3										2

Assessment Pattern

Bloom's Category	Continuous Assessment Tests		End Semester Examination
	1	2	
Remember			
Understand	K2	30	30
Apply	K3	20	20
Analyse			
Evaluate			
Create			

Mark distribution

Total Marks	CIE	ESE	ESE Duration
150	50	100	3 hours

Continuous Internal Evaluation Pattern:

Attendance	: 10 marks
Continuous Assessment Test (2 numbers)	: 25 marks
Assignment/Quiz/Course project	: 15 marks

End Semester Examination Pattern: There will be two parts; Part A and Part B. Part A contain 10 questions with 2 questions from each module, having 3 marks for each question. Students should answer all questions. Part B contains 2 questions from each module of which student should answer any one. Each question can have maximum 2 sub-divisions and carry 14 marks.

Course Level Assessment Questions**Course Outcome 1 (CO1): Understand the fundamentals of statistical detection and estimation principles used in various engineering problems. (K2)**

1. Differentiate estimation and detection techniques.
2. Differentiate classical approach and bayesian approach in detection theory (or estimation).
3. Enumerate different applications which are using estimation and detection techniques.
4. Give the mathematical formulation of estimation and detection methods.
5. Draw receiver operating characteristics with all details
6. Give the significance of Bayes risk
7. How multiple hypothesis testing is done.
8. Give the significance of linear models in estimation and detection theory.
9. Significance of Cramer-Rao Lower Bound in estimation.
10. Differentiate MAP and ML methods in estimation (or detection).

Course Outcome 2 (CO2): Apply various types of statistical decision rules in engineering applications. (K3)

1. Describe Neyman-Pearson theorem (or Bayes risk or minimization of probability of error) and apply it to any binary hypothesis (eg. Signal in white Gaussian noise)
2. Derive/Obtain the matched filters for the detection of deterministic signals
3. Derive/Obtain the estimator-correlator for the detection of random signals

Course Outcome 3 (CO3): Apply different types of estimation algorithms in engineering applications. (K3)

1. Derive/Obtain the Minimum variance unbiased estimator (or best linear unbiased estimator) for any simple examples (eg. DC Signal in white Gaussian noise)
2. Derive/Obtain the Maximum likelihood estimator (or least squares estimator or minimum mean square error estimator) for any simple examples (eg. DC Signal in white Gaussian noise)
3. Using Bayesian approach, obtain an estimator for any simple examples.

SYLLABUS**Module 1 : Introduction to Detection and Estimation Theory**

Fundamentals of detection theory, the mathematical detection problem. Fundamentals of estimation theory, the mathematical estimation problem. Review of Gaussian distribution. Application examples.

Module 2 : Statistical Detection Theory I

Hypothesis testing, classical approach, Neyman-Pearson theorem, likelihood ratio test, receiver operating characteristics, Bayesian approach, minimum probability of error, Bayes risk, multiple hypothesis testing.

Module 3 : Statistical Detection Theory II

Detection of deterministic signals, matched filters, detection of random signals, estimator-correlator, linear model, application examples.

Module 4 : Statistical Estimation Theory I

Minimum variance unbiased estimation, basics of Cramer-Rao Lower Bound, linear models, best linear unbiased estimation, application examples.

Module 5 : Statistical Estimation Theory II

Maximum likelihood estimation, least squares, Bayesian philosophy, minimum mean square error estimation, application examples.

Text Books

1. S.M. Kay, "Fundamentals of Statistical Signal Processing" Vol I: Estimation Theory, Pearson, 3/e, 2010.
2. S.M. Kay, "Fundamentals of Statistical Signal Processing" Vol II: Detection Theory, Pearson, 3/e, 2010.

Reference Books

1. H. L. Van Trees, "Detection, Estimation, and Modulation Theory", Vol. I, John Wiley & Sons, 1968
2. Monson H. Hayes, "Statistical Digital Signal Processing and Modelling" by, John Wiley & Sons, 2002.

Course Contents and Lecture Schedule

No	Topic	No. of Lectures
1	Introduction to Detection and Estimation Theory	
1.1	Fundamentals of detection theory, review of probability and random variable	2
1.2	The mathematical detection problem	2
1.3	Fundamentals of estimation theory	1
1.4	The mathematical estimation problem	2
1.5	Review of Gaussian distribution. Application examples.	2
2	Statistical Detection Theory I	
2.1	Hypothesis testing	2
2.2	Classical approach, Neyman-Pearson theorem	2
2.3	Likelihood ratio test, Receiver operating characteristics	2
2.4	Bayesian approach, minimum probability of error, Bayes risk	2
2.5	Multiple hypothesis testing.	1
3	Statistical Detection Theory II	
3.1	Detection of deterministic signals	1
3.2	Matched filters	2
3.3	Detection of random signals	2
3.4	Estimator-correlator	2
3.5	Linear model, application examples.	2
4	Statistical Estimation Theory I	
4.1	Minimum variance unbiased estimation	2
4.2	Basics of Cramer-Rao Lower Bound	2
4.3	Linear models	2
4.4	Best linear unbiased estimation	2
4.5	Application examples	1
5	Statistical Estimation Theory II	
5.1	Maximum likelihood estimation	2
5.2	Least squares solution	2
5.3	Bayesian philosophy	2
5.4	Minimum mean square error estimation	2
5.5	Application examples	1

Simulation Assignments (using MATLAB or Python)

1. Generate and familiarize PDF and CDF of Normal distribution.
2. Generate DC level in White Gaussian Noise.
3. Simulate a Neyman-Pearson Detector.
4. Simulate a Maximum Likelihood Estimator.
5. Simulate a Best Linear Unbiased Estimator.

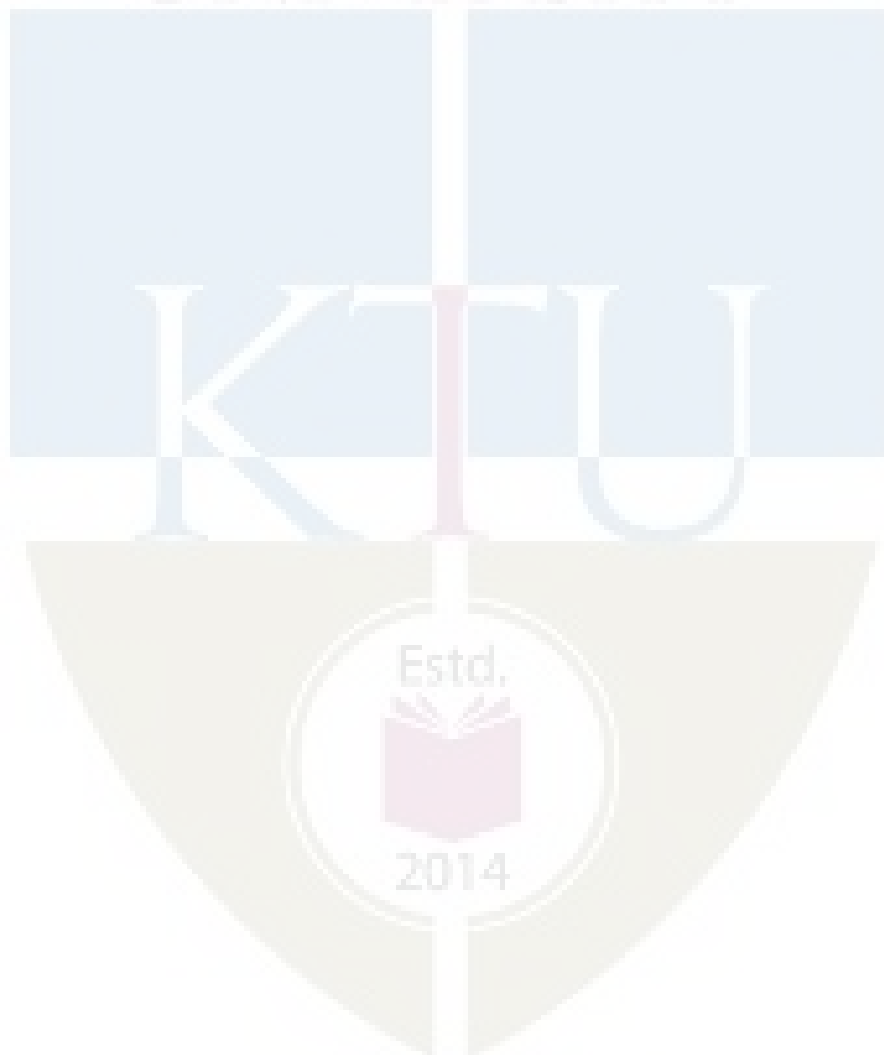

APJ ABDUL KALAM TECHNOLOGICAL UNIVERSITY

SIXTH SEMESTER B.TECH DEGREE EXAMINATION

Max. Marks: 100

ECT 398- Detection and Estimation Theory

Duration: 3 hrs

PART A

(Answer all questions. Each question carries 3 marks each).

1. Enumerate different applications which are using estimation and detection techniques. (3)
2. Differentiate estimation and detection techniques. (3)
3. Differentiate classical approach and bayesian approach in detection theory. (3)
4. Give the mathematical formulation of detection methods. (3)
5. Draw receiver operating characteristics with all details (3)
6. Give the significance of Bayes risk (3)
7. Give the significance of linear models in estimation theory. (3)
8. Significance of Cramer-Rao Lower Bound in estimation. (3)
9. What is Minimum Variance Unbiased Estimation? (3)
10. Differentiate MAP and ML methods in estimation. (3)

PART B

(Answer any one question from each module. Each question carries 14 marks each.)

Note:

(1) Notation $x \sim \mathcal{N}(\mu, \sigma^2)$ denotes x is normally distributed with mean μ and variance σ^2 .

(2) Also, bold small letters indicate vectors and bold capital letters indicate matrices.

11. Obtain the mathematical formulation of estimation method with an example. (14)

OR

12. Using radar system as an example, differentiate estimation and detection techniques. (14)
13. Design Neyman-Pearson detector for the unknown level A in White Gaussian Noise with variance σ^2 . (14)

OR

14. Describe the Bayesian approaches in the design of detectors. (14)
15. Obtain Matched Filter detector for N -sample deterministic signal in noise, $w[n] \sim \mathcal{N}(0, \sigma_n^2)$ where $w[n]$'s are uncorrelated. (14)

OR

16. Describe estimator-correlator in the detection of random signals. (14)

17. Consider the multiple observations (14)

$$x[n] = A + w[n]; \quad n = 0, 1, \dots, N - 1$$

where $w[n] \sim \mathcal{N}(0, \sigma^2)$. Determine CRLB for A?

OR

18. Derive the Best Linear Unbiased Estimator for the multiple observations (14)

$$x[n] = A + w[n]; \quad n = 0, 1, \dots, N - 1$$

where A is an unknown level to be estimated and $w[n]$ is White Noise with unspecified PDF and variance σ^2 .

19. Derive the Maximum Likelihood Estimator for the multiple observations (14)

$$x[n] = A + w[n]; \quad n = 0, 1, \dots, N - 1$$

where A is an unknown level to be estimated and $w[n]$ is White Gaussian Noise with known variance σ^2 .

OR

20. Prove that the optimal estimator which minimizes the Bayesian Mean Square Error is the mean of the posterior PDF. (14)