

APJ ABDUL KALAM
TECHNOLOGICAL
UNIVERSITY

SEMESTER V

KTU



CIVIL ENGINEERING

CORE COURSES – S5

SLOT	COURSE NO.	COURSES	L-T-P	HOURS	CREDIT
A	CET301	STRUCTURAL ANALYSIS – I	3-1-0	4	4
B	CET303	DESIGN OF CONCRETE STRUCTURES	3-1-0	4	4
C	CET305	GEOTECHNICAL ENGINEERING – II	4-0-0	4	4
D	CET307	HYDROLOGY & WATER RESOURCES ENGINEERING	4-0-0	4	4
E	CET309	CONSTRUCTION TECHNOLOGY & MANAGEMENT	3-0-0	3	3
F	MCN301	DISASTER MANAGEMENT	2-0-0	2	--
S	CEL331	MATERIAL TESTING LAB – II	0-0-3	3	2
T	CEL333	GEOTECHNICAL ENGINEERING LAB	0-0-3	3	2
R/M/H	VAC	REMEDIAL/MINOR/HONOURS COURSE	3-1-0	4*	4
TOTAL				27/31	23/27

MINOR COURSES - S5

R/M	CET381	STRUCTURAL MECHANICS	3-1-0	4	4
R/M	CET383	ECO-FRIENDLY TRANSPORTATION SYSTEMS	3-1-0	4	4
R/M	CET385	SUSTAINABILITY ANALYSIS & DESIGN	3-1-0	4	4

HONOURS COURSES - S5

R/M/H	CET393	STRUCTURAL DYNAMICS	3-1-0	4	4
R/M/H	CET395	TRANSPORTATION SYSTEMS MANAGEMENT	3-1-0	4	4
R/M/H	CET397	GROUND WATER HYDROLOGY	3-1-0	4	4

Assessment Pattern

Bloom's Category	Continuous Assessment Tests		End Semester Examination
	1	2	
Remember	10	05	10
Understand	20	10	20
Apply	30	25	50
Analyse	10	10	20
Evaluate			
Create			

Mark distribution

Total Marks	CIE	ESE	ESE Duration
150	50	100	3 hours

Continuous Internal Evaluation Pattern:

- Attendance : 10 marks
- Continuous Assessment Test (2 numbers) : 25 marks
- Assignment/Quiz/Course project : 15 marks

End Semester Examination Pattern: There will be two parts; Part A and Part B. Part A contain 10 questions with 2 questions from each module, having 3 marks for each question. Students should answer all questions. Part B contains 2 questions from each module of which student should answer any one. Each question carries 14 marks and can have maximum 2 sub-divisions.

Course Level Assessment Questions

CO1: Apply the principles of solid mechanics to analyse trusses.

1.	Explain the method of joints to analyse trusses.
2.	Find the member forces in FH, EH and EG using method of sections.
3.	Analyse the truss in figure using method of joints

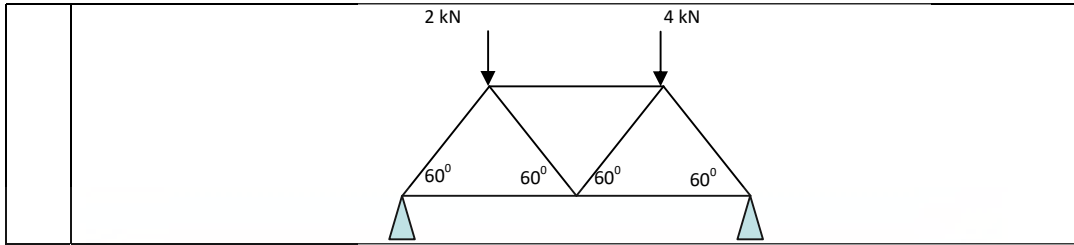

CO2: Apply various methods to determine deflections in statically determinate structures.

1.	<p>Find the slopes at A & B, and deflections at C & D of the simple beam. $E = 2 \times 10^5 \text{ N/mm}^2$. $I = 8500 \text{ cm}^4$</p>
2.	<p>Find the vertical deflection at C for the frame in figure using strain energy method.</p>
3.	<p>State and prove Betti's Theorem</p>
4.	<p>Find the deflection and slope at C for the cantilever, using unit load method. Take EI as unity.</p>

CO3:	<p>Identify the problems with static indeterminacy and tackling such problems by means of the method of consistent deformations and energy principles.</p>
1.	<p>Explain static and kinematic indeterminacies with examples.</p>
2.	<p>Differentiate between force and displacement methods for analysing indeterminate structures</p>

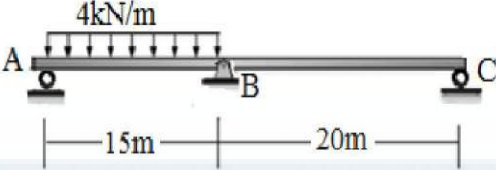
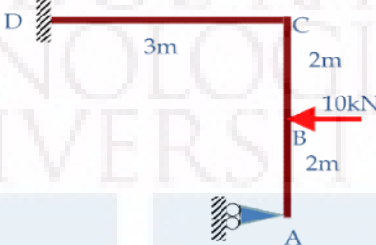
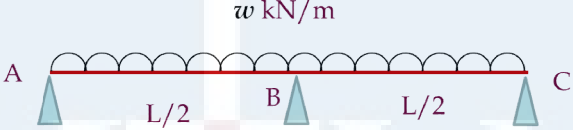
3.	<p>Find the reaction at B for the beam shown in figure, using consistent deformation method.</p> 
4.	<p>Analyse the 2D frame using consistent deformation method (EI is constant).</p> 
5.	<p>Using minimum strain energy method, analyse the continuous beam shown in figure.</p> 

CO4: Apply specific methods such as slope deflection and moment distribution methods of structural analysis for typical structures with different characteristics.

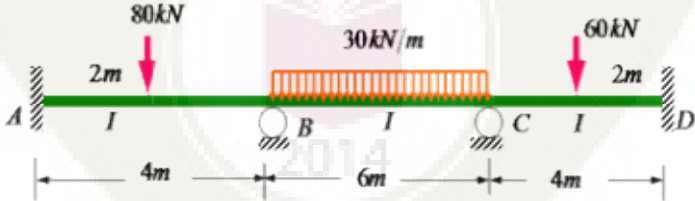
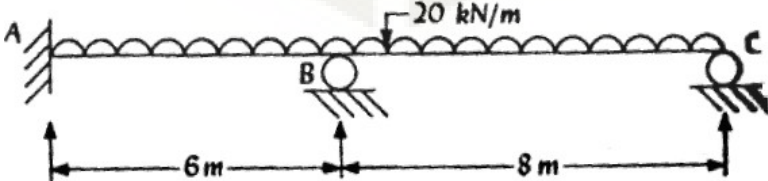
1.	<p>Explain briefly on the analysis of frames with sidesway, using slope deflection method</p>
2.	<p>Derive expressions for stiffness at the near-end for a beam with hinged far-end</p>
3.	<p>Analyse the continuous beam using slope deflection method (EI is constant).</p> 
4.	<p>Analyse the continuous beam in figure using moment distribution method (EI is constant)</p> 

CO5: Apply suitable methods of analysis for various types of structures including cables, suspension bridges and arches.

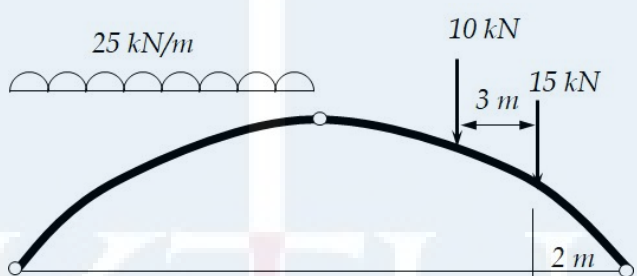
1.	Write a note on three-hinged and two-hinged stiffening girders.
2.	State and explain Eddy's theorem
3.	For a cable AB, the level difference between the supports A and B is 6m, and the lowest point is at a vertical distance of 4.5m from A. If the horizontal span AB is 24m and is loaded with 7.5kN/m throughout the span, find the length of the cable, and the minimum and maximum tension in the cable
4.	A suspension bridge with 25m span and central dip 2.5m transfers 4kN per horizontal metre to each cable. Find max and min pull in each cable, and the length of cable
5.	The span of the 3-hinged parabolic arch shown in figure is 30m and the rise is 6m. Find BM, normal thrust, and radial shear at a section 7.5 m from the left hinge. Find maximum BM on the arch. 

CO6: Analyse the effects of moving loads on structures using influence lines.

1.	State and explain the condition for absolute maximum bending moment in a simple beam when a series of concentrated loads is moving across it
2.	What are influence lines? Draw ILD for SF and BM at any intermediate section of a simply supported beam. What are the uses of influence lines?
3.	Four point loads 30kN, 40kN, 20kN and 15kN, distance between them being 2m, are moving across a simple beam (of span 15m) from left to right with 30kN load leading. Find position of the loads for maximum -ve SF and BM at a section 7m from left end. Also find maximum -ve SF and BM at the section.

SYLLABUS**Module – 1**

Statically determinate trusses: Method of joints and method of sections (simple illustrative numerical problems only) – 4 hrs.

Deflection of statically determinate structures: Introduction and simple illustrative examples of simple beams and cantilever beams only on: a) Method of successive integrations, b) Moment area method and c) Castigliano's theorem Part I – 5hrs.

Module – 2

Principle of virtual work, Betti's theorem, Maxwell's law of reciprocal deflections; Unit load method for determination of deflection of statically determinate beams and trusses (simple illustrative numerical problems only) – 4hrs.

Analysis of Statically Indeterminate Structures:

Degree of static and kinematic indeterminacies; Introduction to force and displacement methods.

Method of consistent deformations: Analysis of beams (simple problems with one redundant, illustration only for two-redundant problems). Concepts of effect of pre-strain, lack of fit, temperature changes and support settlement. (No numerical problems) – 4 hrs.

Castigliano's theorem Part II, theorem of least work. Minimum strain energy method for analysing statically indeterminate structures (Illustrative simple examples only) – 2 hrs.

Module – 3

Slope Deflection Method: Analysis of continuous beams and portal frames without sway; Frames with sway (illustration only); Settlement effects (illustration only) – 5 hrs.

Moment Distribution Method: Analysis of continuous beams and portal frames without sway; Frames with sway (illustration only) – 4 hrs.

Module – 4

Cables: Analysis of forces in cables under concentrated and uniformly distributed loads; Anchor Cable supports – 4 hrs.

Suspension Bridges: Un-stiffened suspension bridges, maximum tension in the suspension cable and backstays, pressure on towers – 5 hrs.

Module – 5

Arches: Theory of arches – Eddy's theorem; Analysis of three-hinged arches; Normal thrust and radial shear due to simple cases of loading. – 4 hrs.

Moving loads and influence lines: Introduction to moving loads - concept of influence lines - influence lines for reaction, shear force and bending moment in simply supported beams and over hanging beams – analysis for single concentrated load, several concentrated loads, uniformly distributed load shorter and longer than the span – conditions for maximum bending moment and shear force – 5 hrs.

Text Books:

1. Gere and Timoshenko, Mechanics of materials, CBS Publishers
2. Kenneth Leet, Chia M Uang & Anne M Gilbert, Fundamentals of Structural Analysis, McGraw Hill
3. R.Vaidyanathan and P.Perumal, Comprehensive Structural Analysis Volume I & II, Laxmi Publications (P) Ltd

References:

1. Wang C.K., Intermediate Structural Analysis, McGraw Hill
2. Aslam Kassimali., Structural Analysis, Cenage Learning
3. Chandramouli P N, Structural Analysis I –Analysis of Statically Determinate Structures, Yes Dee Publishing Pvt Ltd.,Chennai,Tamil Nadu.
4. Devdas Menon, Structural Analysis, Narosa Publications
5. Hibbeler., Structural Analysis, Pearson Education
6. Kinney S., Indeterminate Structural Analysis, Oxford & IBH
7. M.L. Gambhir, Fundamentals of structural Mechanics and analysis, Printice Hall India
8. Reddy C.S., Indeterminate Structural Analysis, Tata McGraw Hill
9. Timoshenko S.P.& Young D.H., Theory of Structures, McGraw Hill
- 10.Daniel L Schodak, Structures, Pearson Education, 7e, 2014
- 11.Negi L. S. and Jangid R. S, Structural Analysis, Tata McGraw Hill, 1997
- 12.Rajasekaran S. and Sankarasubramanian G., Computational Structural Mechanics, PHI, 2008
- 13.S.S. Bhavikatti, Structural Analysis II, Vikas Publication Houses (P) Ltd, 2016
- 14.Utku S, Norris C. H & Wilbur J. B, Elementary Structural Analysis, McGraw Hill, 1990

Lecture Plan –Structural Analysis I

Module	Topic	Course Outcomes addressed	No. of Lectures
1	Module I: Total lecture hours: 9		
1.1	Trusses: Method of joints	CO1	2
1.2	Trusses: Method of sections	CO1	2
1.3	Method of successive integrations	CO2	2
1.4	Moment area method	CO2	2
1.5	Castigliano's theorem Part I	CO2	1
2	Module II: Total lecture hours: 9		
2.1	Principle of virtual work, Betti's theorem, Maxwell's law of reciprocal deflections	CO2	2
2.2	Unit load method for determination of deflection of statically determinate beams and trusses (simple illustrative numerical problems only)	CO2	2
2.3	Degree of static and kinematic indeterminacies; Introduction to force and displacement methods	CO3	1
2.4	Method of consistent deformations: Analysis of beams (simple problems with one redundant, illustration only for two-redundant problems).	CO3	2
2.5	Concepts of effect of pre-strain, lack of fit, temperature changes and support settlement. (No numerical problems)	CO3	1
2.6	Castigliano's theorem Part II, theorem of least work. Minimum strain energy method for analyzing statically indeterminate structures (Illustrative simple examples only)	CO3	1
3	Module III: Total lecture hours: 9		
3.1	Slope Deflection Method: Concept and derivation of basic equations	CO4	1
3.2	Slope Deflection Method: Analysis of continuous beams and portal frames without sway.	CO4	2
3.3	Slope Deflection Method: Frames with sway (illustration only). Settlement effects (derivation only)	CO4	1
3.4	Moment Distribution Method: Concept and derivation of basic equations	CO4	1

3.5	Moment Distribution Method: Analysis of beams and frames – non sway analysis.	CO4	3
3.6	Moment Distribution Method: Sway analysis (illustration only)	CO4	1
4	Module IV: Total lecture hours: 9		
4.1	Cables: Analysis of forces in cables under concentrated and uniformly distributed loads	CO5	3
4.2	Anchor Cable supports	CO5	1
4.3	Suspension Bridges: Un-stiffened suspension bridges, maximum tension in the suspension cable and backstays, pressure on towers.	CO5	5
5	Module V: Total lecture hours: 9		
5.1	Arches: Theory of arches – Eddy's theorem	CO5	1
5.2	Analysis of three hinged arches-Support reactions-normal thrust and radial shear at any section of a parabolic arch due to simple cases of loading	CO5	3
5.3	Moving loads and influence lines: Introduction to moving loads - concept of influence lines	CO6	1
5.4	Influence lines for reaction, shear force and bending moment in simply supported beams and over hanging beams	CO6	1
5.5	Analysis single concentrated load, several concentrated loads, uniformly distributed load shorter and longer than the span. Conditions for maximum shear and bending moment.	CO6	3

MODEL QUESTION PAPER

Reg. No.: _____

Name: _____

APJ ABDUL KALAM TECHNOLOGICAL UNIVERSITY
FIFTH SEMESTER B.TECH DEGREE EXAMINATION

Course Code: CET301

Course Name: STRUCTURAL ANALYSIS I

Max. Marks: 100

Duration: 3 Hours

PART A

Answer all questions; each question carries 3 marks.

1. a) Explain the method of sections to analyse trusses.
- b) State and prove Moment Area Theorem I
- c) Explain the method of consistent deformations, with an example.
- d) State and prove Betti's Theorem.
- e) Explain briefly on the analysis of frames with sidesway, using slope deflection method.
- f) Derive expressions for stiffness at the near-end for a beam with hinged far-end.
- g) Write a note on anchor cable supports.
- h) Write a note on three-hinged and two-hinged stiffening girders.
- i) State and explain Eddy's theorem.
- j) State and explain the condition for absolute maximum bending moment in a simple beam when a series of concentrated loads is moving across it.

(10×3 marks = 30 marks)

PART B

Answer one full question from each module; each full question carries 14 marks.

Module I

2. a. Find the member forces in FH and EH and EG using method of sections.

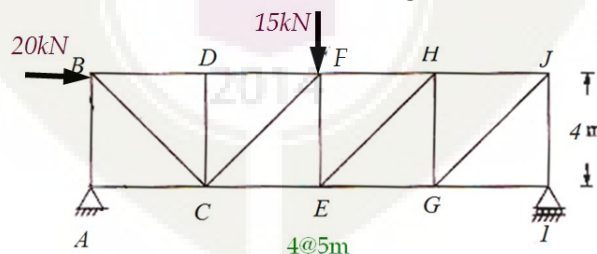

(6 marks)

- b. Analyse the truss in figure using method of joints.

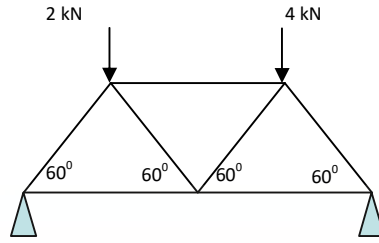

(8 marks)

3. a. Find the slope at A and deflection at C of the simple beam using the method of successive integrations. $E = 2 \times 10^5 \text{ N/mm}^2$. $I = 8500 \text{ cm}^4$.

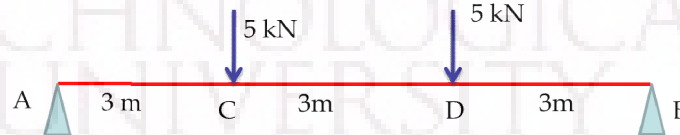

(7 marks)

- b. Find the slope and deflection at B of the cantilever using moment area method. $w = 10 \text{ kN/m}$, $l = 3 \text{ m}$, $E = 2 \times 10^5 \text{ N/mm}^2$, $I = 8500 \text{ cm}^4$

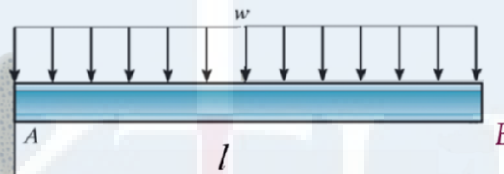

(7 marks)

Module II

4. a. Find the deflection at E of the truss in figure, using unit load method. Cross-sectional areas of members are 1200 mm^2 . $E = 200 \text{ kN/mm}^2$.

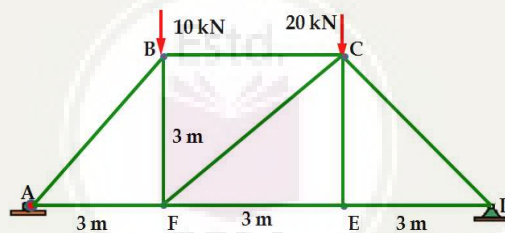

(7 marks)

- b. Find the deflection and slope at C for the cantilever, using unit load method. Take EI as unity.

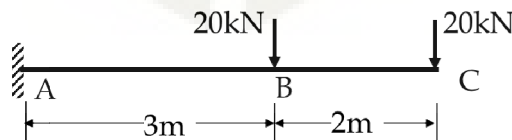

(7 marks)

5. a. Find the reaction at B for the beam shown in figure, using consistent deformation method.

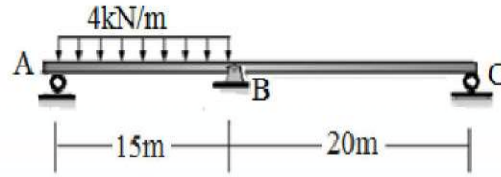

(7 marks)

- b. Analyse the 2D frame using consistent deformation method (EI is constant).

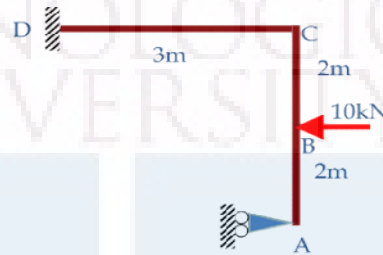

(7 marks)

Module III

6. Analyse the continuous beam using slope deflection method (EI is constant).

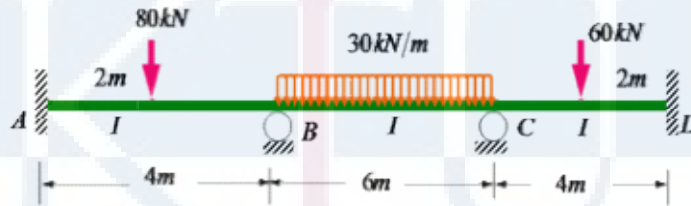

(14 marks)

7. Analyse the continuous beam in figure using moment distribution method (EI is constant).

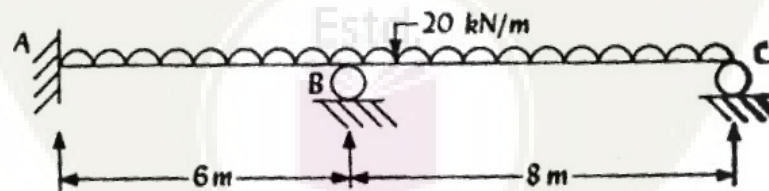

(14 marks)

Module IV

8. For a cable AB, the level difference between the supports A and B is 6m, and the lowest point is at a vertical distance of 4.5m from A. If the horizontal span AB is 24m and is loaded with 7.5kN/m throughout the span, find the length of the cable, and the minimum and maximum tension in the cable.

(14 marks)

9. A suspension bridge with 25m span and central dip 2.5m transfers 4kN per horizontal metre to each cable. Find max and min pull in each cable, and the length of cable. (14

marks)

Module V

10. The span of the 3-hinged parabolic arch shown in figure is 30m and the rise is 6m. Find BM, normal thrust, and radial shear at a section 7.5 m from the left hinge. Find maximum BM on the arch.

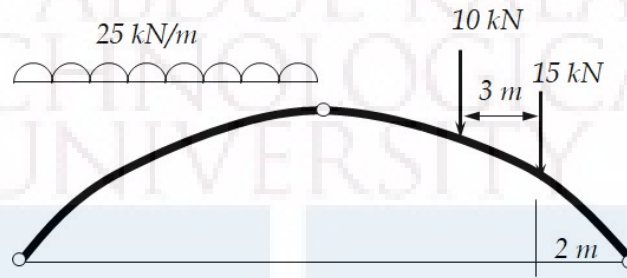

(14 marks)

11. a) What are influence lines? Draw ILD for SF and BM at any intermediate section of a simply supported beam. (5 marks)
- b) Four point loads 30 kN , 40 kN , 20 kN and 15 kN , distance between them being 2 m , are moving across a simple beam (of span 15 m) from left to right with 30 kN load leading. Find position of the loads for maximum -ve SF and BM at a section 7 m from left end. Also find maximum -ve SF and BM at the section. (9 marks)

Assessment Pattern

CIVIL ENGINEERING

Bloom's Category	Continuous Assessment Tests		End Semester Examination
	1	2	
Remember			
Understand	10	10	30
Apply	30	30	60
Analyse	10	10	10
Evaluate			
Create			

Mark distribution

Total Marks	CIE	ESE	ESE Duration
150	50	100	3 hours

Continuous Internal Evaluation Pattern:

Attendance : 10 marks

Continuous Assessment Test (2 numbers) : 25 marks

Assignment/Quiz/Course project : 15 marks

End Semester Examination Pattern: There will be two parts; Part A and Part B. Part A contain 10 questions with 2 questions from each module, having 3 marks for each question. Students should answer all questions. Part B contains 2 questions from each module of which student should answer any one. Each question carries 14 marks and can have maximum 2 sub-divisions.

Course Level Assessment (Sample) Questions

CO1: Recall the fundamental concepts of limit state design and code provisions for design of concrete members under bending, shear, compression and torsion.

1. Explain the term limit state design.
2. Enumerate the five limit states commonly used in limit state design and state briefly how they are provided for in design.
3. Define the term partial safety factor as used in limit state design. Identify the various factors and state the values recommended in IS 456
4. Explain the term 'factored load' and 'characteristic loads. Why IS 456 specifies the same partial safety factor for dead and live loads? Is it technically correct?
5. How are the following factors incorporated in design formulae for limit design
 - (a) partial safety factor for load,
 - (b) partial safety factor for material strength,

- (c) difference between cube strength and strength of concrete in structure.
6. Explain the basis for the selection of partial load and safety factors by the Code for serviceability limit states
 7. Why is the partial safety factor for concrete (γ_c) greater than that for reinforcing steel (γ_s) in the consideration of ultimate limit states?
 8. Explain the necessity for specifying maximum and minimum tension steel in reinforced beams. What are their values?
 9. What is equivalent shear as applied to torsion and shear in IS 456?
 10. Explain the terms 'balanced', 'over reinforced' and 'under reinforced' section. Explain which of these should be recommended in design. How is this ensured in design of beams according to IS 456?
 11. Why is it necessary to put a limit on the x/d allowed in singly reinforced beams as stipulated in IS 456? Can this condition be relaxed for beams with compression steel? Give reasons for your answer
 12. What are the types of reinforcements used to resist shear? Explain the action of different types of shear steel in resisting shear.
 13. What is meant by equivalent length of a column? Explain how column behaviour is affected by the effective length.
 14. Why is it necessary to have lateral ties in a column?
 15. How do helically reinforced columns differ from tied columns in their behaviour? In what situations would one recommend the use of helically reinforced column?

CO2: Analyse reinforced concrete sections to determine the ultimate capacity in bending, shear and compression.

1.	A rectangular beam 250mm wide and effective depth 450 mm has 4 bars of 20mm diameter. Find the moment of resistance of the section if M20 concrete and Fe 415 grade steel are used. As per IS 456:2000 find the limiting moment of resistance also.
2.	A rectangular RC beam 230 mm wide and 420 mm effective depth is reinforced with 2-16mm diameter bars at top and 4 – 16 mm bars at bottom. Estimate the ultimate moment carrying capacity of the section assuming M20 concrete and Fe415 steel.
3.	A rectangular beam 250mm wide and effective depth 450 mm has 4 bars of 20mm diameter. 8mm diameter two legged vertical stirrups are provided at 200 mm c/c. Determine the ultimate SF the section can resist. Assume M20 concrete and Fe415 steel.
4.	A square column 300 mm x 300 mm is reinforced with 8 bars of 16 mm diameter. Assuming M25 concrete and Fe415 steel, determine the safe axial load carrying capacity of the column

CO3: Design and detail beams, slab, stairs and footings using IS code provisions.

1. Design a simply supported beam of span 6m subjected to a live load of 4 kN/m. Use M20 concrete and Fe415 steel.
2. Design a simply supported rectangular beam to carry a superimposed load of 30kN/m over a span of 5.5m. Assume support width as 300mm. Maximum overall depth is restricted to 550mm. Use M20 concrete and Fe 415 grade steel.
3. Design a slab for a room of size 3mx5.5m carrying a live load of 7 kN/m². Use M20 concrete and Fe 415 grade steel. Assume that the corners are held down. The slab is having all the four edges discontinuous
4. Design a square isolated footing for a column of size 400mm x 400mm carrying a load of 1500 kN under service conditions. Safe bearing capacity of soil is 200 kN/m². Use M20 concrete and Fe 415 grade steel.
5. Design and detail an isolated rectangular footing for a column 400 mm x 600 mm to carry a load of 2000 kN. The SBC of the soil is 180 kN/m². Use M20 concrete and Fe 415 grade steel
6. A dog-legged staircase for a residential flat consists of 18 steps, each of 300 mm tread 180 mm rise, with an intermediate landing 1.2 m in width at the middle. The width of staircase is also 1.2 m. If the flights are of equal number of steps, design the staircase detail the steel. $f_{ck} = 20 \text{ N/mm}^2$ and $f_y = 415 \text{ N/mm}^2$.
7. Explain the design detail of a combined rectangular footing with reinforcement details.

CO4: Design and detail columns using IS code and SP 16 design charts.

1. Design a RCC rectangular column to carry an axial load of 1200 kN and a moment of 70 kNm, The length of the column is 3.5m. The one end is fixed and the other end is hinged. The width of the column is restricted to the wall thickness of 24 cm.
2. Design a reinforced concrete column to carry an axial load of 1600 kN. Use M20 concrete and Fe415 steel. The column has unsupported length of 3m and is effectively held in position at both the ends, but not restrained against rotation.
3. Design and detail a column under biaxial bending with the following data:
 Size of column = 40 x 60cm
 The column is effectively held in position at both ends but not restrained against rotation. The unsupported length of column is 3.5m
 Concrete grade = M20
 Grade of Steel = Fe 415
 Factored load $P_u = 1900 \text{ kN}$
 Factored Moment $M_{ux} = 150 \text{ kNm}$ and $M_{uy} = 110 \text{ kNm}$
4. A short column 300 mm x 600 mm is carrying an axial working load of 750 kN and a moment of 160 kNm at an axis bisecting the depth. Design the reinforcement required if $f_y = 250 \text{ N/mm}^2$ and $f_{ck} = 20 \text{ N/mm}^2$, Also sketch the reinforcement.

CO5: Explain the criteria for earthquake resistant design of structures and ductile detailing of concrete structures subjected to seismic forces.

1. What are the objectives of earthquake-resistant design of reinforced concrete structures?
2. What are the objectives behind the special detailing provisions in IS 13920?
3. Distinguish between ordinary moment resisting frame (OMRF) and special moment resisting frame (SMRF)
4. How do you fix the minimum width of columns of moment resisting frames in Zone III?
5. What are the design requirements of beam-column joints?
6. What is meant by special confining reinforcement in columns of ductile frames?
7. What are the design requirements of beam-column joints in earthquake resistant design?

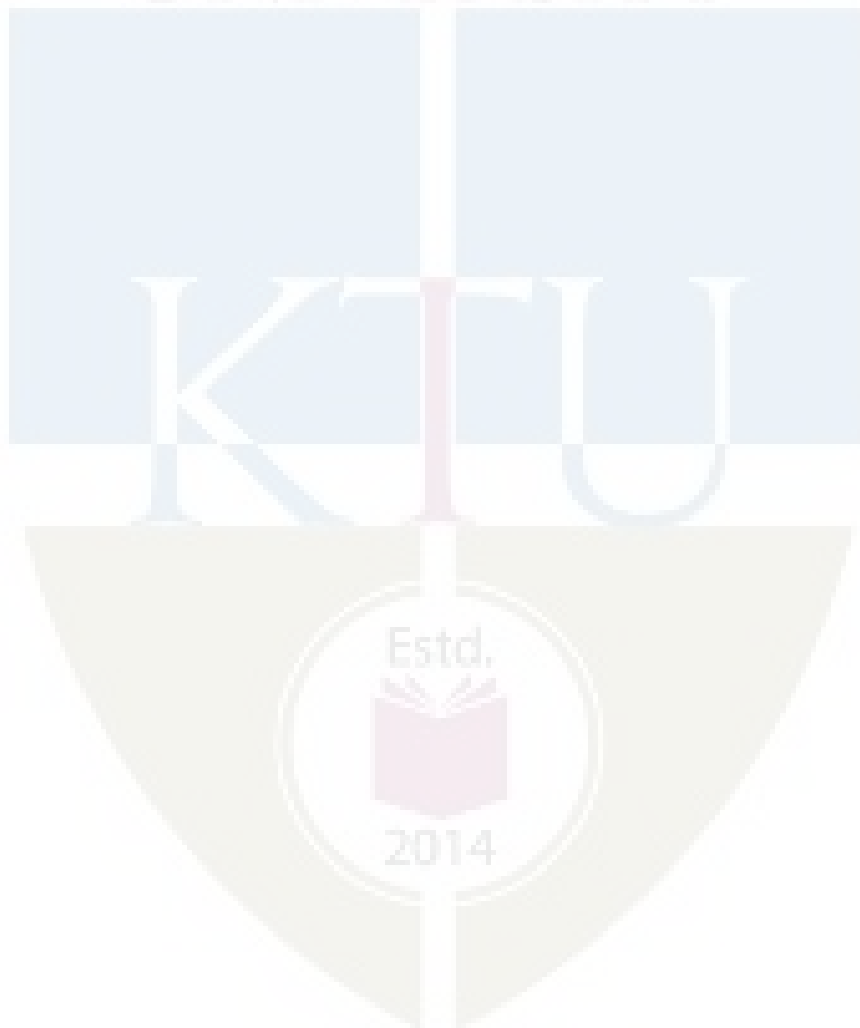

SYLLABUS

CIVIL ENGINEERING

Module I

Introduction – Limit states – Limit state of collapse in flexure – Analysis and design of singly reinforced beams.

Module II

Analysis & design of doubly reinforced beams. Analysis of T-beams . Limit state of collapse in shear. Bond and development length.

Module III

Design of slabs – one way and two way slabs. Design of stair case.

Module IV

Limit state of collapse – compression, Design of axially loaded short column.

Design of short columns subjected to compression and uniaxial/biaxial bending- design using SP16 charts.

Module V

Design of isolated and combined footings.

Limit state of serviceability.

Introduction to earthquake resistant design. Codal provisions – IS 1893, IS 13920

Text Book:

1. Punmia, B. C, Jain A.K and, Jain A.K , R C C Designs, Laxmi Publications Ltd., 10e, 2015

References:

1. Pillai S.U & Menon D – Reinforced Concrete Design, Tata McGraw Hill Book Co., 2009
2. Varghese P.C, Limit State Design of Reinforced Concrete, Prentice Hall of India Pvt Ltd, 2008
4. Relevant IS codes (IS 456, IS 875, IS 1893, IS 13920, SP 16, SP 34)

Lecture Plan –Design of Concrete Structures

Module	Topic	Course Outcomes addressed	No. of Lectures
1	Module I : Total lecture hours : 9		
1.1	Introduction – Principles of Limit state method of design, Introduction to BIS code- Types of limit states-characteristic and design values-partial safety factors-types of loads and their factors.	CO1	2
1.2	Limit State of Collapse by flexure -assumptions-stress-strain relationship of steel and concrete-	CO1	2

1.3	Analysis of singly reinforced rectangular beams-balanced-under reinforced-over reinforced sections-moment of resistance codal provisions	CO2	2
1.4	Design of singly reinforced rectangular beams- basic rules for design-.	CO3	1
1.5	Design example of simply supported beam- design of cantilever beam-detailing	CO3	2
2	Module II : Total lecture hours : 9		
2.1	Analysis of doubly reinforced beams	CO2	1
2.2	Design of doubly reinforced beams –detailing,	CO3	1
2.3	T-beams- terminology- Formulae for analysis of T beams- examples –	CO1,CO2	2
2.4	Limit state of collapse in shear and bond- shear stresses in beams-types of reinforcement-shear strength of RC beam-IS code recommendations for shear design-	CO1	2
2.5	Design of shear reinforcement-examples	CO3	1
2.6	Bond and development length - anchorage for reinforcement bars - code recommendations regarding curtailment of reinforcement	CO1, CO3	1
2.7	Design for torsion-IS code approach- examples	CO3	1
3	Module III : Total lecture hours : 10		
3.1	Design of slabs- introduction- one-way and two-way action of slabs - load distribution in a slab-	CO1,CO3	1
3.2	IS recommendations for design of slabs- design of one-way slab- numerical problems – concepts of detailing of continuous slab –code coefficients.	CO1,CO3	2
3.3	Two- way slabs- simply supported design using IS Code coefficients Reinforcement detailing	CO1,CO3	2
3.4	Two- way slabs- restrained slabs – design using IS Code coefficients Reinforcement detailing	CO1,CO3	2
3.5	Stair cases- Types-proportioning-loads- distribution of loads – codal provisions –Concepts of tread-riser type stairs (detailing only)	CO1,CO3	1
3.6	Design and detailing of dog legged stair-	CO1,CO3	2
4	Module IV : Total lecture hours : 9		
4.4	Columns- introduction –classification- effective length-short column - long column - reinforcement-IS specifications regarding columns- limit state of collapse: compression -	CO1,CO4	1
4.5	Design of axially loaded short columns-design examples	CO4	2

	with rectangular ties		
4.6	Design of axially loaded short columns-design examples with helical reinforcement	CO4	2
5.1	Analysis and design of short columns subjected to compression and uniaxial bending- design using SP16 charts for limit state	CO4	2
5.2	Analysis and design of short columns subjected to combined axial load and biaxial bending moments-code procedure for design- design using SP16 charts for limit state	CO2,CO4	2
5	Module V : Total lecture hours : 11		
5.3	Foundations- classification-IS code provisions for design of isolated footings-	CO1, CO3	2
5.4	Design principles of rectangular footings- detailing.	CO1, CO3	2
5.5	Combined footings (design principles only)- analysis of combined footings-rectangular and trapezoidal.	CO1, CO3	2
4.1	Limit state of serviceability - limit state of deflection- short term and long term deflection-	CO1	1
4.2	Limit state of serviceability - IS code recommendations- limit state of cracking- estimation of crack width- simple numerical examples	CO1	2
4.3	Introduction to earthquake resistant design, Importance of Ductility in Seismic Design, Major Design Considerations, Codal provisions – IS 1893, IS 13920	CO5	2



Reg. No.: _____

Name: _____

APJ ABDUL KALAM TECHNOLOGICAL UNIVERSITY
FIFTH SEMESTER B.TECH DEGREE EXAMINATION

Course Code: CET303

Course Name: Design of Concrete Structures

Max. Marks: 100

Duration: 3 Hours

PART A

Answer all questions; each question carries 3 marks.

1.
 - a) Derive the limiting values of depth of neutral axis for different grades of steel
 - b) Define characteristic strength & partial safety factor for materials. Why is partial safety factor for material high for concrete than steel?
 - c) Explain the term development length and explain its significance in RC design. obtain the expression for it
 - d) Explain why and how shear reinforcement is provided in beams
 - e) Explain the difference in the behaviour of one-way and two-way slabs. Why it is essential to provide corner reinforcement in two way rectangular slabs whose corners are prevented from lifting up?
 - f) What is meant by stair supported on landings? Explain the codal provision for the effective span of the stair slab in such cases?
 - g) What are the objectives behind the special detailing provisions in IS 13920?
 - h) Compare the behaviour of tied columns with spiral column subject to axial loading.
 - i) Explain how interaction curves are used in the design of column
 - j) Explain at what situations a combined footing is recommended.

(10×3 marks = 30 marks)

PART B

Answer one full question from each module; each full question carries 14 marks.

Module I

2.
 - (a) Explain balanced, under reinforced and over reinforced sections in the context of Limit State Design of Reinforced Concrete structures. **(4 marks)**
 - (b) A rectangular beam 250mm wide and effective depth 450 mm has 4 bars of 20mm diameter. Find the moment of resistance of the section if M20 concrete and Fe 415 grade steel are used. As per IS 456:2000 find the limiting moment of resistance also. **(10 marks)**
3.
 - (a) Explain the term Limit State. Enumerate the different limit states to be considered in reinforced concrete design. **(4 marks)**
 - (b).Design and detail an RC rectangular section subjected to a udl of 15 kN/m over the entire span. Clear span is 5m. The beam is supported on masonry walls, 230 mm thick on

both sides. Assume moderate exposure conditions. Use M 25 grade concrete and Fe 415 grade steel.(10 marks)

CIVIL ENGINEERING

Module II

4. (a) Enumerate the situations in which a doubly reinforced section become necessary. Derive expression for the ultimate moment of resistance of doubly reinforced section Explain. (4 marks)
- (b) Determine the ultimate moment of resistance of a doubly reinforced rectangular section of width 300 mm and overall depth 700 mm reinforced with 4 – 25mm diameter bars on tension side and 2 – 25mm diameter bars on compression side. Assume effective cover of 45 mm on both sides. Use M 20 concrete and Fe 415 steel.(10 marks)
5. (a) The provision of minimum stirrup reinforcement is mandatory in all reinforced concrete beams. Why?(2 marks)
- (b) Determine the ultimate moment of resistance of an isolated beam of T-shaped cross-section having a span of 6m and cross sectional dimensions are flange width of 1000mm, flange thickness of 100mm, web width of 250mm and an effective depth of 520mm, having tension reinforcement of 6 x 28mm diameter bars. The materials used are concrete mix of grade M20 and mild steel of grade Fe 415. (12 marks)

Module III

6. (a) Distinguish between one way slab and two way slab. (2 marks)
- (b) Design and detail a simply supported slab for a room of interior dimension 5m x 4m subjected to an imposed load of 8 kN/m². Thickness of supporting wall is 230 mm. Use M 20 concrete and Fe 415 grade steel.(12 marks)
7. (a) Explain the behavior of two way slabs and also the need of corner reinforcement in two way rectangular slabs whose corners are prevented from lifting.(3 marks)
- (b) Design a staircase to be provided in a residential building in two straight opposite flights of 1.0m width connected by a landing for a floor height of 3.3m. The landing which is 1m wide spans in the same direction as the stair slab. The rise and tread shall be 150mm and 270mm respectively. The weight of finishes 1kN/m², live load =3kN/m². M20 concrete & Fe415 steel are to be used.(11 marks)

Module IV

8. (a)Classify the columns separately based on loadings and slenderness ratios.(4 marks)
- b)Design a reinforced concrete column to carry an axial load of 1600 kN. Use M20 concrete and Fe415 steel. The column has unsupported length of 3m and is effectively held in position at both the ends, but not restrained against rotation.(10 marks)
9. a)Draw four typical strain profiles of a short, rectangular and symmetrically reinforced concrete column causing collapse subjected to different pairs of P_u and M_u when the depths of the neutral axis are (i) less than the depth of column D , (ii) equal to the depth of column D , (iii) $D < x_u < \infty$ and (iv) $x_u = \infty$. Explain the behaviour of column for each of the four strain profiles. (4 marks)

(b) Design a RCC rectangular column to carry an axial load of 1200 kN and a moment of 70 kNm, The length of the column is 3.5m. The one end is fixed and the other end is hinged. The width of the column is restricted to the wall thickness of 24 cm.(10 marks)

Module V

10. (a) Design a footing for a 400 mm x 400 mm column to carry a load of 100 kN with foundation resting on a soil of SBC 120 kN/m². Assume M20 concrete and Fe415 steel. (8 marks)

(b) What are the objectives of earthquake-resistant design of reinforced concrete structures? What are the design requirements of beam-column joints in earthquake resistant design? (6 marks)

11. (a) Explain the different types of shallow footings.(2 marks)

(b) Design an isolated rectangular footing for a column 450 mm x 600 mm to carry a load of 2400 kN. The SBC of the soil is 180 kN/m². Use M20 concrete and Fe 415 grade steel. (10 marks)

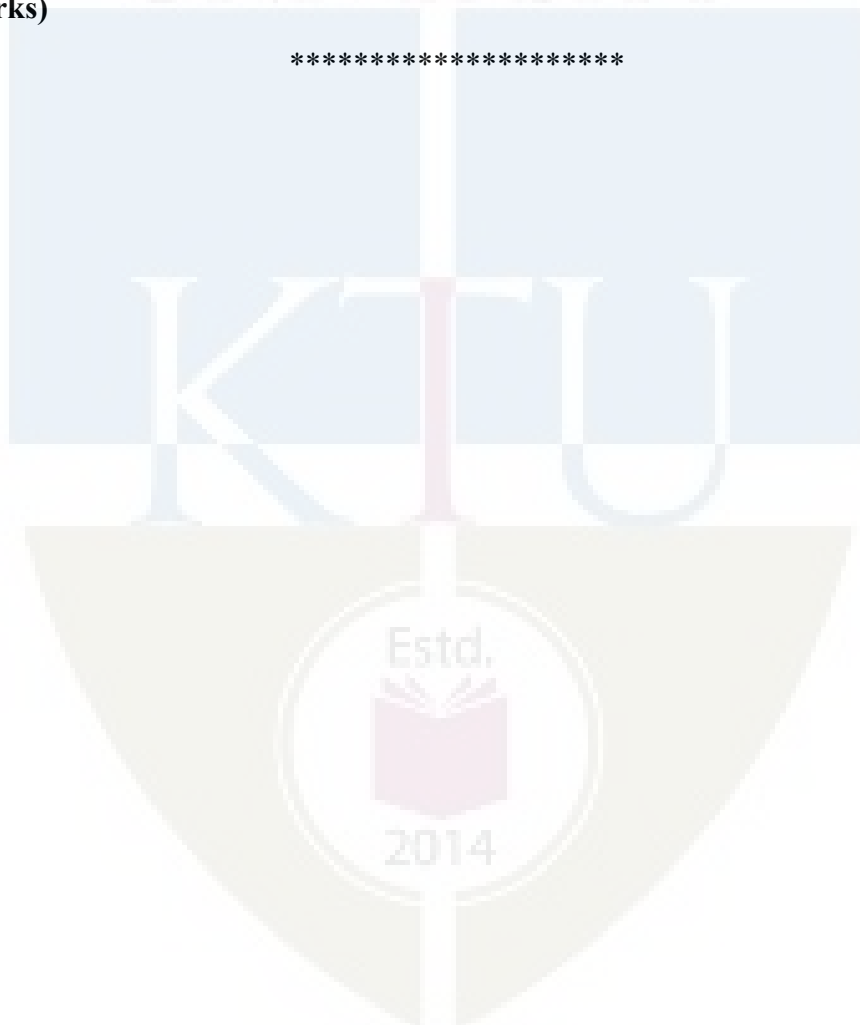

CET 305	GEOTECHNICAL ENGINEERING - II	CATEGORY	L	T	P	CREDIT	Year of Introduction
		PCC	4	0	0	4	2019

Preamble: Goal of this course is to impart to the students, in-depth knowledge about the basic concepts and theories of foundation engineering. After this course, students will be able to recognize practical problems of foundations in real-world situations and respond accordingly.

Prerequisite : Geotechnical Engineering - I

Course Outcomes: After completion of the course the student will be able to:

CO 1	Understand soil exploration methods
CO 2	Explain the basic concepts, theories and methods of analysis in foundation engineering
CO 3	Calculate bearing capacity, pile capacity, foundation settlement and earth pressure
CO 4	Analyze shallow and deep foundations
CO 5	Solve the field problems related to geotechnical engineering

Mapping of course outcomes with program outcomes (Minimum requirement)

	PO 1	PO 2	PO 3	PO 4	PO 5	PO 6	PO 7	PO 8	PO 9	PO 10	PO 11	PO 12
CO 1	3	-	-	3	-	-	-	-	-	-	-	-
CO 2	3	-	-	-	-	-	-	-	-	-	-	-
CO 3	2	3	-	-	-	-	-	-	-	-	-	-
CO 4	2	2	3	-	-	-	-	-	-	-	-	-
CO 5	3	3	-	-	-	-	-	-	-	-	-	-

Assessment Pattern

Bloom's Category	Continuous Assessment Tests		End Semester Examination (Marks)
	Test 1 (Marks)	Test 2 (Marks)	
Remember	5	5	10
Understand	10	10	20
Apply	25	25	50
Analyse	10	10	20
Evaluate			
Create			

Mark Distribution

Total Marks	CIE Marks	ESE Marks	ESE Duration
150	50	100	3 hours

Continuous Internal Evaluation (CIE)Pattern :

Attendance	: 10 Marks
Continuous Assessment Test (2 numbers)	: 25 Marks
Assignment/Quiz/Course project	: 15 Marks

End Semester Examination (ESE)Pattern : There will be two parts; Part A and Part B. Part A contains 10 questions with 2 questions from each module, having 3 marks for each question. Students should answer all questions. Part B contains 2 questions from each module of which student should answer any one. Each question can have maximum 2 sub-divisions and carry 14 marks.

Course Level Assessment Questions

(Questions may be framed based on the outline given under each course outcome)

Course Outcome 1 (CO1):

1. Understand Soil Investigation and Soil Exploration methods

Course Outcome 2 (CO2):

1. Explain the bearing capacity theory of shallow foundations
2. Explain the basic concepts and theory of settlement calculations of shallow foundations
3. Explain the concepts and theory of pile capacity
4. Explain the earth pressure theories for cohesionless and cohesive soils

Course Outcome 3 (CO3):

1. Calculate the bearing capacity of shallow foundations
2. Calculate pile capacity
3. Calculate the settlement of footings
4. Calculate the earth pressure acting on retaining walls

Course Outcome 4 (CO4):

1. Analyze and design shallow foundations
2. Analyze deep foundations

Course Outcome 5 (CO5):

1. Solve the field problems related to different types of shallow and deep foundations, retaining walls, etc.

SYLLABUS

CIVIL ENGINEERING

Module 1

Earth pressure : Earth pressure - At rest, active and passive earth pressures - Practical examples Rankine's theory – Earth pressure and point of application for cohesionless and cohesive soils - Influence of surcharge and water table on earth pressure - Numerical problems - Earth pressure with layered backfill - Numerical problems - Coulomb's theory [no derivation required] – Comparison of Rankine's and Coulomb's theory

Foundation – General Considerations : Functions of foundations - definition of shallow and deep foundation - Selection of type of foundation - Different types of shallow foundations - advantages and limitations of various types of shallow foundations

Module 2

Bearing capacity of shallow foundations: Gross and Net bearing pressure - Ultimate and Safe bearing capacity - Failure mechanism - Allowable soil pressure - Terzaghi's bearing capacity theory for strip footing [no derivation required] – Assumptions – Bearing capacity factors - Numerical problems - Terzaghi's formulae for circular and square footings - Numerical problems - Factors affecting bearing capacity - Effect of water table on bearing capacity - Numerical problems - General, local and punching shear failure - Skempton's formula – Numerical problems

Module 3

Settlement analysis: Introduction- causes of settlement – estimation of immediate settlement – Numerical problems - Allowable settlement-Maximum and differential settlements as per Indian standard - Field test - Plate load test – Procedure, uses and limitations

Footings :Principles of design of footings – strip/continuous and individual footings - Numerical Problems - Combined footings- Rectangular and Trapezoidal combined footings - Numerical problems - Footings subjected to eccentric loading

Raft foundations: Types – Principles of design of raft foundation- Bearing capacity equations for raft on sand (Teng's equation based on SPT value) and for raft on clay (Skempton's formula) - Floating foundations - conventional design procedure for rigid mat.

Module 4

Pile foundations: uses of piles - classification of piles - determination of type and length of piles - Bearing capacity of single pile in clay and sand [I.S. Static formulae] - Numerical problems - Dynamic formulae (Modified Hiley formulae only) – Numerical Problems - I.S. Pile load test [conventional] - Negative skin friction - Group action - Group efficiency - Capacity of Pile groups - Numerical problems

Well foundation : Elements of a well foundation – construction details of well foundations - Problems encountered in well sinking – Methods to rectify tilts and shifts

Module 5

Site investigation and soil exploration: objectives - planning - reconnaissance - Guidelines for choosing spacing and depth of borings [I.S. guidelines only]- Methods of subsurface exploration - test pits - Auger borings – Wash Boring - Rotary drilling - Standard Penetration Test – procedure and correlations - Corrections for SPT value – Numerical Problems - Sampling - disturbed samples, undisturbed samples and chunk samples - types of samplers - Sampler parameters - Boring log - Soil

profile- Location of Water table - Geophysical methods : Seismic Refraction method and Electrical Resistivity method (in brief).

CIVIL ENGINEERING

Text Books:

1. Ranjan G. and A. S. R. Rao, Basic and Applied Soil Mechanics, New Age International, 2002.
2. Arora K. R., Geotechnical Engineering, Standard Publishers, 2006.

References:

1. Das B. M., Principles of Geotechnical Engineering, Cengage India Pvt. Ltd., 2010.
2. Venkatramaiah, Geotechnical Engg, Universities Press, 2000.
3. Terzaghi K. and R. B. Peck, Soil Mechanics in Engineering Practice, John Wiley, 1967.
4. A V Narasimha Rao and C Venkatramaiah, Numerical Problems, Examples and Objective questions in Geotechnical Engineering, Universities Press (India) Ltd., 2000
5. Purushothamaraj P., Soil Mechanics and Foundation Engineering, Dorling Indersley(India) Pvt. Ltd., 2013
6. Taylor D.W., Fundamentals of Soil Mechanics, Asia Publishing House, 1948.

Course Contents and Lecture Schedule:

Module	Contents	Outcomes Addressed	Hours
1	Module 1		9
1.1	Earth pressure : Earth pressure - At rest, active and passive earth pressures - Practical examples	CO 2 & CO 5	1
1.2	Rankine's theory – Earth pressure and point of application for cohesionless and cohesive soils	CO 2	1
1.3	Influence of surcharge and water table on earth pressure - Numerical problems	CO 2 & CO 3	2
1.4	Earth pressure with layered backfill - Numerical problems	CO 2 & CO 3	2
1.5	Coulomb's theory [no derivation required] – Comparison of Rankine's and Coulomb's theory	CO 2	1
1.6	Foundation – General Considerations: Functions of foundations - definition of shallow and deep foundation - Selection of type of foundation	CO 4 & CO 5	1
1.7	Different types of shallow foundations- advantages and limitations of various types of shallow foundations	CO 4 & CO 5	1
2	Module 2		9
2.1	Bearing capacity of shallow foundations: Gross and Net bearing pressure - Ultimate and Safe bearing capacity	CO 2	1
2.2	Failure mechanism - Allowable soil pressure	CO 2	1

2.3	Terzaghi's bearing capacity theory for strip footing [no derivation required] – Assumptions – Bearing capacity factors	CO 2	1
2.4	Numerical problems	CO 3	1
2.5	Terzaghi's formulae for circular and square footings - Numerical problems	CO 2 & CO 3	1
2.6	Factors affecting bearing capacity - Effect of water table on bearing capacity	CO 2	1
2.7	Numerical problems	CO 3	1
2.8	General, local and punching shear failure	CO 2 & CO 3	1
2.9	Skempton's formula – Numerical problems	CO 2 & CO 3	1
3	Module 3		9
3.1	Settlement analysis: Introduction- causes of settlement – estimation of immediate settlement – Numerical problems	CO 2 & CO 3	1
3.2	Allowable settlement-Maximum and differential settlements as per Indian standard	CO 2 & CO 5	1
3.3	Field test - Plate load test – Procedure, uses and limitations	CO 3 & CO 5	1
3.4	Footings :Principles of design of footings – strip/continuous and individual footings - Numerical Problems	CO 4	1
3.5	Combined footings- Rectangular and Trapezoidal combined footings	CO 4	1
3.6	Numerical problems	CO 4	1
3.7	Footings subjected to eccentric loading	CO 4	1
3.8	Raft foundations: Types – Principles of design of raft foundation- Bearing capacity equations for raft on sand (Teng's equation based on SPT value) and for raft on clay (Skempton's formula)	CO 3 & CO 4	1
3.9	Floating foundations - conventional design procedure for rigid mat.	CO 2 & CO 4	1
4	Module 4		9
4.1	Pile foundations: Uses of piles - classification of piles - determination of type and length of piles	CO 2 & CO 5	1
4.2	Bearing capacity of single pile in clay and sand [I.S. Static formulae]	CO 2	1
4.3	Numerical problems	CO 3	1
4.4	Dynamic formulae (Modified Hiley formulae only) – Numerical Problems	CO 2 & CO 3	1
4.5	I.S. Pile load test [conventional]	CO 5	1
4.6	Negative skin friction - Group action - Group efficiency	CO 2	1
4.7	Capacity of Pile groups - Numerical problems	CO 3 & CO 4	1
4.8	Well foundation : Elements of a well foundation – construction details of well foundations	CO 2 & CO 5	1

4.9	Problems encountered in well sinking – Methods to rectify tilts and shifts	CO 2 & CO 5	1
5	Module 5		9
5.1	Site investigation and soil exploration: objectives - planning - reconnaissance	CO 1	1
5.2	Guidelines for choosing spacing and depth of borings [I.S. guidelines only]	CO 1	1
5.3	methods of subsurface exploration - test pits - Auger borings – Wash Boring - Rotary drilling	CO 1	1
5.4	Standard Penetration Test – procedure and correlations	CO 1	1
5.5	Corrections for SPT value – Numerical Problems	CO 1	1
5.6	Sampling - disturbed samples, undisturbed samples and chunk samples	CO 1	1
5.7	types of samplers - Sampler parameters	CO 1	1
5.8	Boring log - soil profile- Location of Water table	CO 1	
5.9	Geophysical methods: Seismic Refraction method and Electrical Resistivity method (in brief).	CO 1	1

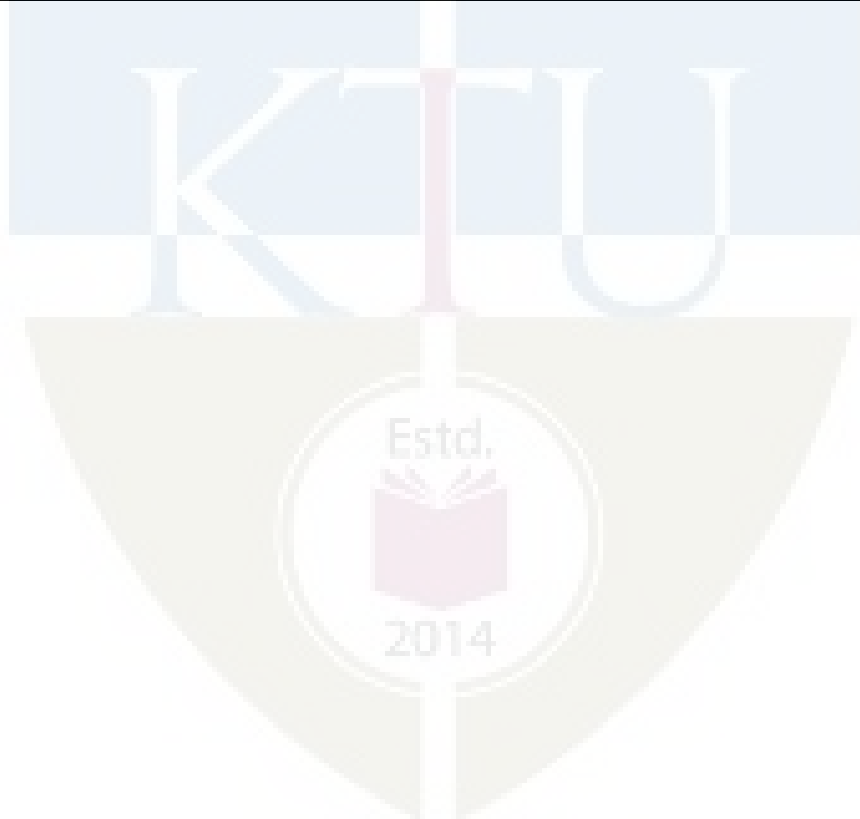

Reg No.: _____

Name: _____

APJ ABDUL KALAM TECHNOLOGICAL UNIVERSITY
FIFTH SEMESTER B.TECH DEGREE EXAMINATION, MONTH & YEAR

Course Code: CET305

Course Name : GEOTECHNICAL ENGINEERING - II

Max. Marks: 100

Duration: 3 hours

Part A

(Answer all questions; each question carries 3 marks)

1. List the assumptions of Rankine's theory of earth pressure.
2. Explain the situations in which combined footings are provided.
3. Write the assumptions of Terzaghi's method for bearing capacity.
4. Explain the factors affecting bearing capacity.
5. Explain Allowable settlement.
6. Explain floating foundation.
7. Explain negative skin friction.
8. List the elements of a well foundation.
9. List Objectives of soil exploration.
10. Define (i) Inside clearance, (ii) Outside clearance and (iii) Area ratio as applied to sampler.

PART B

(Answer one full question from each module, each question carries 14 marks)

Module – 1

17. (a) Explain different types of earth pressures with practical examples. (6 Marks)
(b) A wall of 8m height retains a non-cohesive layered backfill. Top 3 m soil is having $\gamma = 18\text{kN/m}^3$ and $\phi = 30^\circ$. Bottom 5 m soil is having $\gamma = 17.5\text{ kN/m}^3$ and $\phi = 28^\circ$. Using Rankine's theory, find the total active thrust on the wall and the point of application. (8 Marks)
18. (a) A 6m high retaining wall with vertical back supports soil which is in level with the top of retaining wall carries a uniform surcharge load of 20kPa. Backfill properties are $c = 5\text{ kN/m}^2$, $\gamma = 18.5\text{ kN/m}^3$, $\phi = 30^\circ$. Determine Rankine's passive earth pressure on the retaining wall. (6 Marks)
(b) A 6m high retaining wall with vertical back supports soil which is in level with the top of retaining wall. Backfill properties are $c = 5\text{ kN/m}^2$, $\gamma = 18\text{ kN/m}^3$, $\phi = 30^\circ$. Find the maximum depth up to which excavation can safely be done without the sides caving in? Also determine Rankine's active earth pressure on the retaining wall before the formation of tension crack. (8 Marks)

Module – 2

11. (a) Differentiate between General shear failure and local shear failure. (6 Marks)
- (b) A strip footing of 2.0 m wide is to be founded at a depth of 1.6 m in a soil with following data:
 $\gamma = 19 \text{ kN/m}^3$; $c = 10 \text{ kN/m}^2$; $\phi = 40^\circ$
 $N_c = 95.7$; $N_q = 81.3$; $N_\gamma = 100.4$
- Determine the safe bearing capacity with a FS of 3, when
- Water table is at great depth
 - Water table is at a depth of 1.0 m from ground level.
 - Water table is at a depth of 3.0 m from ground level. (8 Marks)
12. (a) A Circular footing rests in pure clay with unconfined compressive strength $q_u = 200 \text{ kN/m}^2$ at a depth of 1.5 m. Using Skempton's method, determine the diameter of footing if it has to transmit a net load of 1000 kN. Take FS = 3. (6 Marks)
- (b) A square footing 2m x 2m is at a depth of 1.5 m in a soil with $c = 30 \text{ kN/m}^2$, $\phi = 35^\circ$, ($N_c = 57.8$, $N_q = 41.4$ and $N_\gamma = 42.4$). Take $\gamma = 18 \text{ kN/m}^3$. Calculate the net safe load that can be carried by footing. (8 Marks)

Module – 3

13. (a) A rectangular surface footing 2m x 3m carries a column load of 600 kN. The footing rests on a $c-\phi$ soil strata 6 m thick having $\mu = 0.25$ and E as 5000 kN/m^2 . Calculate the immediate settlement of footing assuming the influence factor $I_f = 1.36$. (6 Marks)
- (b) Explain Plate Load Test with neat sketch. List the limitations of plate load test. (8 Marks)
16. (a) What are the different types of raft foundations? Under what circumstances raft foundations are preferred? (6 Marks)
- (b) Design a rectangular combined footing for uniform pressure for the column loads of 1000 kN and 1500 kN at column A and B respectively. Projection of footing beyond centre line of column A is restricted to 0.5 m. Distance of c/c of columns is 5 m. Net Allowable pressure = 150 kN/m^2 .
- Design a suitable combined footing if projection beyond centre line of both columns restricted to 0.5 m. (8 Marks)

Module – 4

19. (a) Explain the classification of pile foundations based on installation. (6 Marks)
- (b) A RCC pile weighs 25 kN is driven by drop hammer weighing 35 kN, having effective fall of 0.85 m. Average set/blow is 1.3 cm. Take elastic compression as 1.6 cm. Assuming coefficient of restitution as 0.25. Find ultimate and safe load on pile by assuming factor of safety of 2.5. (8 Marks)
20. (a) Explain any three methods (with neat sketches) for rectification of tilts in a well foundation. (6 Marks)
- (b) A bored pile in a clayey soil is 50 cm diameter and 10 m long, determine the capacity of a 3X3

pile group spaced 1 m centre to centre both ways. Take $C_u = 70 \text{ kN/m}^2$ and $\alpha = 0.6$.

(8 Marks)

Module – 5

14. (a) Explain Augur boring and wash boring methods used in soil exploration. (6 Marks)
- (b) Explain Standard Penetration Test? How this is correlated with shear strength parameters? What are the corrections to the observed SPT (N) value? (8 Marks)
15. (a) A SPT is conducted in a sand deposit at a depth of 16 m. Water table is at 7 m below ground level. Unit weight of sand is 18 kN/m^3 above water table and 19 kN/m^3 below water table. If N value is 36, find the corrected N value. (6 Marks)
- (b) Explain Geophysical Exploration using Seismic Refraction Method. What are its limitations? (8 Marks)

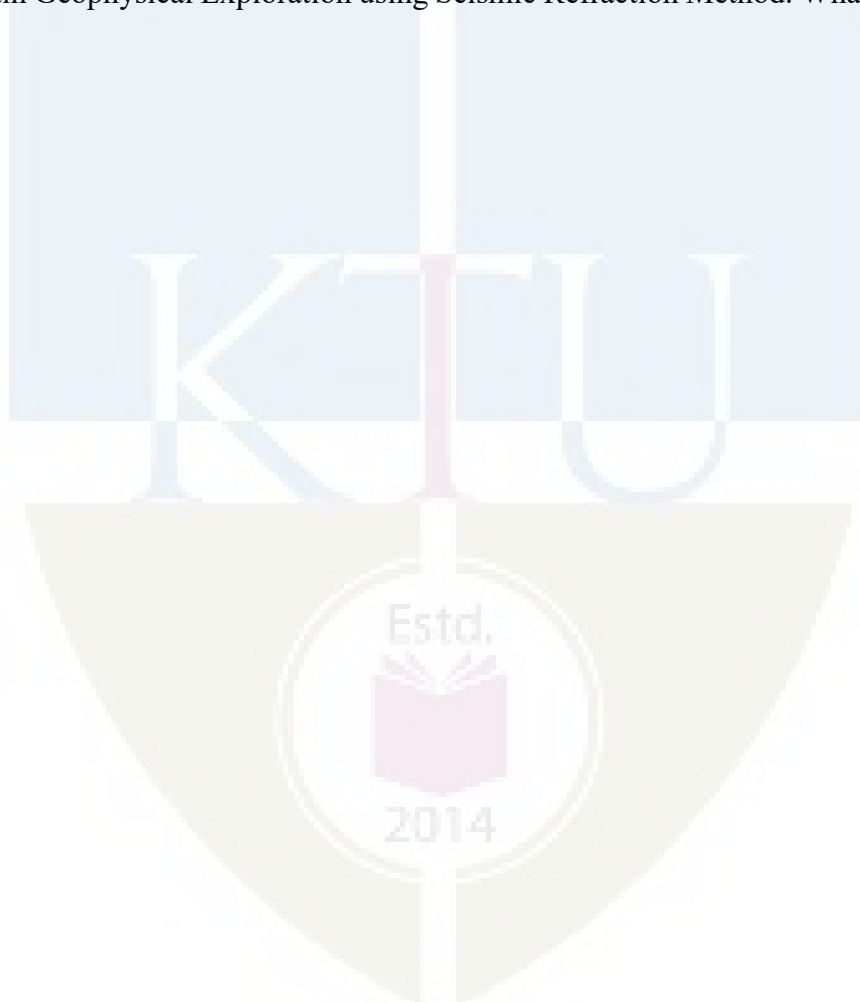

CET 307	HYDROLOGY & WATER RESOURCES ENGINEERING	Category	L	T	P	Credit	Year of Introduction
		PCC	4	0	0	4	2019

Preamble: The general objective of this course is to expose the students to the fundamental concepts of surface and groundwater components of hydrology and basics of water resources engineering. The course aim to impart the knowledge on the availability of water on hydrosphere, its distribution and quantification, scientific methods for computing irrigation water requirements, reservoir engineering and river engineering

Pre-requisite: NIL

Course outcome

After the course, the student will be able to:

CO1	Describe and estimate the different components of hydrologic cycle by processing hydro-meteorological data
CO2	Determine the crop water requirements for the design of irrigation canals by recollecting the principles of irrigation engineering
CO3	Perform the estimation of streamflow and/or describe the river behavior and control structures
CO4	Describe and apply the principles of reservoir engineering to estimate the capacity of reservoirs and their useful life
CO5	Demonstrate the principles of groundwater engineering and apply them for computing the yield of aquifers and wells

CO - PO Mapping

CET307 Hydrology and Water Resources		PO1	PO2	PO3	PO4	PO5	PO6	PO7	PO8	PO9	PO10	PO11	PO12
	CO1	3	3		1			1					
	CO2	3	3					1					
	CO3	3	2					1					
	CO4	3	3					1					
	CO5	3	3					1					

Assessment pattern

Bloom's Category	Continuous Assessment Tests		End Semester Examination (Marks)
	Test 1 (Marks)	Test 2 (Marks)	
Remember	5	5	15
Understand	10	10	15
Apply	20	20	40
Analyze	15	15	30
Evaluate			
Create			

Continuous Internal Evaluation Pattern:

Attendance	:	10 marks
Continuous Assessment Test (2 numbers)	:	25 marks
Assignment/Quiz/Course project	:	15 marks
Total	:	50 marks

End semester examination pattern – There will be two parts; Part A and Part B. Part A contain 10 questions with 2 questions from each module, having 3 marks for each question. Students should answer all questions. Part B contains 2 questions from each module of which student should answer any one. Each question can have maximum 2 sub-divisions and carry 14 marks.

Course Code: CET 307
Hydrology and Water Resources Engineering
(Course Level Assessment Questions)

CO1	Describe and estimate the different components of hydrologic cycle by processing hydro-meteorological data
1	Differentiate rainfall mass curve and hyetograph
2	Explain the use of double ring infiltration for infiltration measurement
3	Explain any three methods for baseflow separation
4	Explain the limitations of unit hydrograph theory
5	A storm with 10 cm of precipitation produced a direct runoff of 5.8 cm. The duration of the rainfall was 16 hrs and its time distribution is given below : (10 Marks)

	Time from start (h)	0	2	4	6	8	10	12	14	16				
	Cumulative rainfall (cm)	0	0.4	1.3	2.8	5.1	6.9	8.5	9.5	10				
Determine the ϕ -index of the storm.														
6	The ordinates of a 4-hour unit hydrograph for a particular basin are given below. Determine the ordinates of the 6-hour unit hydrograph.													
	Time (hrs)	0	2	4	6	8	10	12	14	16	18	20	22	24
	Discharge (Cumecs)	0	25	100	160	190	170	110	70	30	20	16	1.5	0

CO2	Determine the crop water requirements for the design of irrigation canals by recollecting the principles of irrigation engineering
1	Explain the factors affecting duty. Explain how can you improve the duty
2	Define duty and delta. Obtain the relation between the two
3	Define the different types of irrigation efficiencies
4	The following data pertaining to healthy growth of a crop: Root zone depth = 75 cm Field capacity = 27 %, Wilting point=14 % Dry density of soil=1500 kg/m ³ . Daily consumptive use =11 mm. Assuming 80 % depletion of available moisture as an indicator for application of water, determine how long the crop survive without irrigation
5	The CCA for a distributary is 15000 ha. The intensity of irrigation for Rabi is 40 % and for Kharif is 15 %. If the total water requirement of the two crops is 37.5 cm and 120 cm and their periods of growth are 160 days and 140 days respectively, determine the design discharge at the outlet.

CO3	Perform the estimation of streamflow and/or describe the river behavior and control structures												
1	Explain Meandering. What are the causes of meandering ?												
2	Explain the objectives of providing river training works												
3	Enlist the factors affecting the selection of site for stream gauging station												
4	The data pertaining to a stream gauging operation at a gauging station are given below. The rating equation of the current meter is $v = 0.32N_s + 0.032$ m/sec where N_s is the number of revolutions per second. Compute the discharge in the stream by area velocity method												
	Distance from left water edge (m)	0	2	4	6	9	12	15	18	20	22	23	24
	Depth (m)	0	0.5	1.1	1.95	2.25	1.85	1.75	1.65	1.5	1.25	0.75	0
	Revolutions of current meter kept at 0.6 depth	0	80	83	131	139	121	114	109	92	85	70	0
	Duration of observation (s)	0	180	120	120	120	120	120	120	120	120	120	120
5	Describe with sketches different type of groynes												

CO4	Describe and apply the principles of reservoir engineering to estimate the capacity of reservoirs and their useful life												
1	Define safe yield, secondary yield and design yield of reservoirs												
2	Explain mass inflow curve and mass demand curve												
3	Explain with a neat sketch the zones of a storage reservoir												
4	Explain the procedure for estimating the life of storage reservoir												

5	The average annual discharge of a river for 11 years is given below											
	Year	1960	61	62	63	64	65	66	67	68	69	70
	Discharge (m ³ /sec)	1750	2650	3010	2240	2630	3200	1000	950	1200	4150	3500
Determine the storage capacity of a reservoir required to meet a demand of 2000 cumec throughout the year by mass curve method.												

CO5	Demonstrate the principles of groundwater engineering and apply them for computing the yield of aquifers and wells
1	State Darcy's law and its limitations
2	Enlist the assumptions in the derivation of Dupuit's equation
3	Differentiate perched aquifer and leaky aquifer
4	Describe the working of strainer type tube well with a sketch
5	Pumping at the rate of 1500 litres per minute from a 30cm diameter well of depth 60m in an unconfined aquifer gives a drawdown of 2m and 1.1m in observation wells located at distances 120m and 160m respectively from it. Calculate the drawdown of the pumping well and the coefficient of permeability of the aquifer.
6	During a recuperation test conducted on an open well in a region, the water level in the well was depressed by 3 m and it was observed to rise by 1.75 m in 75 minutes. (a) What is the specific yield of open wells in that region (b) What will be the yield from a well of 5 m diameter under a depression head of 2.5 m ? (c) What diameter should be the diameter of the well to give a yield of 12 l/sec under a depression head of 2 m ?

Course Code: CET 307
Hydrology and Water Resources Engineering
Syllabus

Module I

Hydrologic cycle-precipitation-mechanism, types, forms and measurement using rain gauges ; Optimum number of rain gauges, representation of rainfall data-mass curve and hyetograph, computation of mean precipitation over a catchment, Design rainfall - probable maximum rainfall; IDF curves (conceptual idea only). Infiltration-measurement by double ring infiltrometer, Horton's model, infiltration indices. Evaporation –measurement and control

Module II

Runoff-components of runoff- Hydrograph analysis-Hydrograph from isolated storm-Base flow separation. Unit hydrograph – uses, assumptions and limitations of unit hydrograph theory. Computation of storm/flood hydrograph of different duration by method of superposition and by development of S– Hydrograph; Floods-methods of design flood estimation –Empirical methods; SPF and PMF, Return period (conceptual ideas only)

Module III

Irrigation– Necessity, Benefits and ill effects. Types: flow and lift irrigation - perennial and inundation irrigation. Soil-water –plant relationships. Irrigation efficiencies, Computation of crop water requirement: depth and frequency of Irrigation. Duty and delta, duty-factors affecting and method of improving duty, Computation of crop water requirement by using the concept of duty and delta

Module IV

Streamflow measurement-area velocity method of stream gauging, selection of site for stream gauging station, Stage-discharge curve, flow duration curve-uses and characteristics. River training works-types; Meandering and meander parameters; Reservoirs- types, zones, yield of reservoir; determination of storage capacity and yield by mass curve method; Reservoir sedimentation and control- trap efficiency- computation of life of reservoir

Module V

Vertical distribution of ground water- classification of saturated formation (review) Aquifer properties, Darcy's law, Well hydraulics-Steady radial flow into a fully penetrating well in Confined and Unconfined aquifers; Types of wells, Types of tube wells; well losses; Yield of open wells-pumping test and recuperation test

Text Books:

1. Modi P. N. Irrigation, Water Resources and Water Power Engineering, S.B.H Publishers and Distributors New Delhi 2009.
2. Punmia B.C. Ashok K Jain, Arun K Jain, B. B. L Pande, Irrigation and Water Power Engineering, Laxmi Publications (P) Ltd. 2009

References:

3. VenTe Chow. Hand book of Applied Hydrology, Tata McGraw Hill, 1988
4. Todd D. K. Ground Water Hydrology, Wiley, 2005.
5. H.M Raghunath. Groundwater. New Age International New Delhi 2007
6. G.L.Asawa. Irrigation and Water Resources Engineering New Age International New Delhi 2008
7. Garg S. K. Hydrology and Water Resources Engineering, Khanna Publishers New Delhi 2005.
8. Garg SK, Irrigation Engineering and Hydraulic Structures Khanna Publishers New Delhi 2006.
9. Subramanya K. Engineering Hydrology, Tata McGraw Hill, 2013.
10. Raghunath H.M. Hydrology: Principles, Analysis and Design. New Age International New Delhi 2006.

Course Code: CET 307

**Hydrology and Water Resources Engineering
(Course plan)**

Module	Topic	Course outcome addressed	No of Hours
Module I (11 Hours)			
1.1	Hydrology-Hydrologic cycle	CO1	1
1.2	Precipitation- mechanism, types, forms	CO1	1
1.3	Measurements of rainfall- Use of rain gauges	CO1	1
1.4	Representation of rainfall data-Rainfall Mass curve, hyetograph; Optimum number of rain gauges	CO1	1
1.5	Estimation of missing precipitation	CO1	1
1.6	Computation of mean precipitation	CO1	1
1.7, 1.8	Problems	CO1	2
1.9	Design rainfall - probable maximum rainfall; IDF curves	CO1	1

	(conceptual idea only).		
1.10	Water losses-Infiltration-measurement by double ring infiltrometer, Horton's equation; concept of infiltration indices	CO1	1
1.11	Evaporation-measurement by IMD land pan, control of evaporation	CO1	1
Module II (9 Hours)			
2.1	Runoff- Components, factors affecting runoff, Computation of runoff by different methods.	CO1	1
2.2	Runoff computation by rational formula and from infiltration indices	CO1	1
2.3	Hydrograph analysis-Hydrograph from isolated storm-Base flow separation	CO1	1
2.4	Concept of unit hydrograph-assumptions, uses, applications	CO1	1
2.5	Computation of storm/flood hydrograph ordinates of different duration by method of superposition	CO1	1
2.6	Computation of storm/flood hydrograph ordinates of different duration by development of S-Hydrograph	CO1	1
2.7,2.8	Problems	CO1	2
2.9	Floods-methods of design flood estimation –Empirical methods; SPF and PMF, Return period (conceptual ideas only)	CO1	1
Module III (7 Hours)			
3.1	Irrigation-Benefits and ill effects, lift and flow irrigation	CO2	1
3.2	Types of irrigation, Irrigation efficiencies	CO2	1
3.3	Soil water plant relationships	CO2	1
3.4	Computation of crop water requirement: depth and frequency of Irrigation	CO2	1
3.5	Duty and delta-Factors affecting and method of improving duty	CO2	1
3.6	Estimation of crop water requirement by using the concepts of duty and delta	CO2	1
3.7	Problems	CO2	1
Module IV (11 Hours)			
4.1	Streamflow measurement- measurement of stage and velocity	CO3	1
4.2	Stage-discharge curve- Selection of site for stream gauging station,	CO3	1
4.3	Computation of discharge (Area-velocity method)-problem	CO3	1
4.4	Flow duration curves-uses and characteristics	CO3	1
4.5	River behavior-meandering-meander parameters, Objectives of river training	CO3	1
4.6	Types of river training works	CO3	1

4.7	Reservoirs- types, zones, yield of reservoir	CO4	1
4.8	Storage capacity and yield-by mass curve method	CO4	1
4.9	Reservoir sedimentation-control of sedimentation, trap efficiency	CO4	1
4.10	Useful life of reservoir-computation.	CO4	1
4.11	Problems	CO4	1
Module V (7 Hours)			
5.1	Vertical distribution of ground water - classification of saturated formation (Review)	CO5	1
5.2	Aquifer properties- Darcy's law	CO5	1
5.3	Steady radial flow to a well-unconfined aquifers	CO5	1
5.4	Steady radial flow to a well-unconfined aquifers	CO5	1
5.5	Problems	CO5	1
5.6	Types of wells-open wells and tube well, Types of tube wells - description	CO5	1
5.7	Estimation of yield of an open well- pumping test and recuperation test	CO5	1

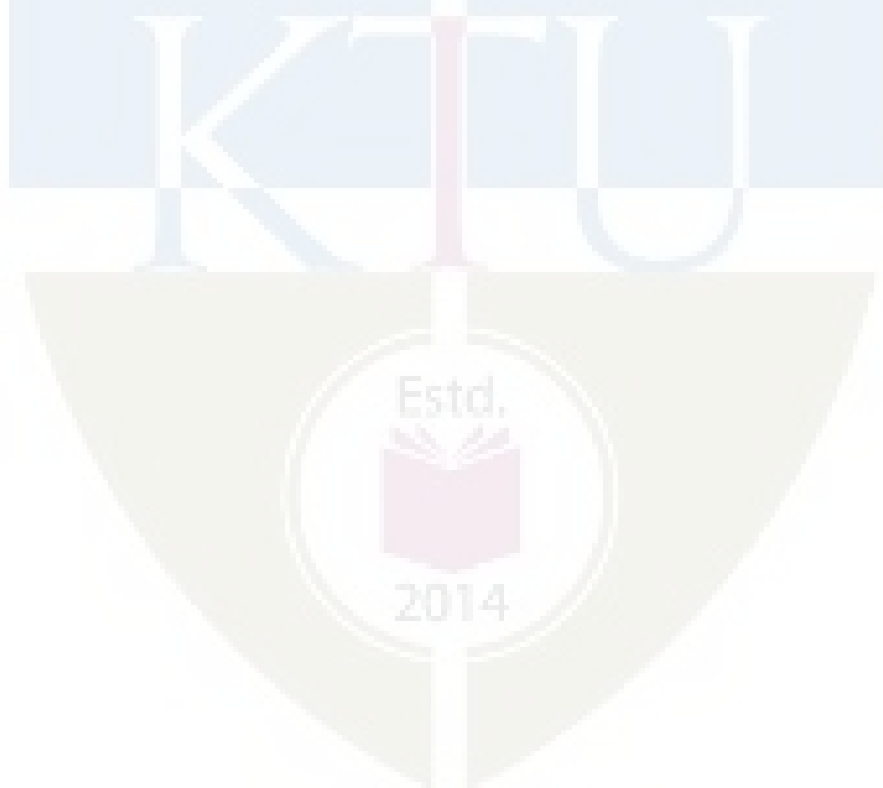

Pages: 3

Model Question Paper

Reg No.:.....

QP

CODE:.....

Name:.....

**APJ ABDUL KALAM TECHNOLOGICAL UNIVERSITY
FIFTH SEMESTER B.TECH DEGREE EXAMINATION, MONTH & YEAR**

Course Code: CET 307

Hydrology and Water Resources Engineering**Max. Marks: 100
hours****Duration: 3****Part A****(Answer all questions; each question carries 3 marks)**

1. Explain the different forms of precipitation
2. What are the methods of control of evaporation from water bodies?
3. Define unit hydrograph. Explain its uses
4. State the limitations of rational formula for runoff estimation
5. Explain irrigation efficiencies
6. Define duty and delta. Obtain the relation between the two
7. Enlist the factors to be considered in the selection of site for a stream gauging station
8. Explain meandering of rivers
9. Define (i) Storativity (ii) Transmissibility
10. Explain well losses

Part B**(Answer one full question from each module, each question carries 14 marks)****Module I**

- 11 (a) Explain the working of a Siphon type rain gauge with a neat sketch (5 Marks)

- (b) The average rainfall of 5 rain gauge stations in the base stations are 89, 54, 45, 41 and 55 cm. If the error in the estimation rainfall should not exceed 10 %, how many additional gauges may be required to be installed in the catchment? (9 Marks)

OR

- 12.(a) Compare different methods for determination of mean precipitation from a catchment (6 Marks)
- (b) Explain the use of double ring infiltrometer for the measurement of infiltration. How will you develop Horton's model? (8 Marks)

Module II

- 13.(a) The rates of rainfall for the successive 30 min period of a 3-hour storm are:1.6, 3.6, 5.0, 2.8, 2.2, 1.0 cm/hr. The corresponding surface runoff is estimated to be 3.6 cm. Estimate the ϕ -index (7 Marks)
- (b) Explain the characteristics of a single peak hydrograph from an isolated storm. How will you separate the base flow? (7 Marks)

OR

14. Find out the ordinates of a storm hydrograph resulting from a 9 hr storm with rainfall of 2, 5.75 and 2.75 cm during subsequent 3 hr intervals. The ordinates of 3hr unit hydrograph at 3 hr intervals are 0, 100, 355, 510, 380, 300, 260, 225,165, 120,85, 55,30, 22, 10, 0 (cumecs). Assume an initial loss of 0.5 cm and ϕ -index of 2.5 mm/hr and abase flow of 10 cumecs. (14 Marks)

Module III

15. (a) Differentiate lift irrigation and flow irrigation. (4 Marks)
- (b) Estimate the frequency of irrigation required for certain crop for the following data: Root zone depth = 90 cm Field capacity = 22 %, Wilting point=12 % Dry density of soil=1500 kg/m³. Daily Consumptive use =22 mm. Assume 70 % depletion of available moisture as an indicator for application of water (10 Marks)

OR

16. (a) Explain the benefits and ill effects of irrigation (4 Marks)

(b) What are the factors affecting duty? How can you improve the duty of water.

(10 Marks)

Module IV

17 (a) Explain the use of current meter for velocity measurement in streams (7 Marks)

(b) Explain the method of determination of useful life of a reservoir. (7 Marks)

OR

18 (a) Explain the features of different types of groynes (8 Marks)

(b) Explain the types of storage reservoirs (6 Marks)

Module V

19 (a) State Darcy's law and its limitations (4 Marks)

(b) The following observations were recorded during a pumping out test on a tube well penetrating fully in an aquifer: Well diameter: 25 cm, Discharge from the well: 300 m³/hr, RL of original water surface before pumping started: 122.000, RL of water in the well at constant pumping: 117.100, RL of water in the observation well: 121.300, RL of impervious layer: 92.000, radial distance of observation well from the tube well: 50 m. Determine : (a) field permeability coefficient of the aquifer (b) radius of zero drawdown.

(10 Marks)

OR

20.(a) Explain the method of determination of yield of an open well (7 Marks)

(b) Explain the working of a strainer type tube well with a sketch (7 Marks)

CET309	CONSTRUCTION TECHNOLOGY AND MANAGEMENT	CATEGORY	L	T	P	CREDIT	Year of Introduction
		PCC	3	0	0	3	2019

Preamble:

Construction Technology and Management introduces the basic concepts of civil engineering construction and its management. The course provides a detailed insight into the materials used in construction, various building elements and construction technology. Management is essential for successful completion of construction projects and the course introduces the students to the basic concepts of construction project management and planning. After the course, students will be familiar with the fundamental concepts of building construction and management.

Prerequisite: Basics of Civil and Mechanical Engineering

Course Outcomes: After completion of the course, the student will be able to

Course Outcome	Description of Course Outcome	Prescribed learning level
CO1	Describe the properties of materials used in construction	Understand
CO2	Explain the properties of concrete and its determination	Understand
CO3	Describe the various elements of building construction	Understand
CO4	Explain the technologies for construction	Understand
CO5	Describe the procedure for planning and executing public works	Understand
CO6	Apply scheduling techniques in project planning and control	Application

Mapping of course outcomes with program outcomes(Minimum requirement)

	PO1	PO2	PO3	PO4	PO5	PO6	PO7	PO8	PO9	PO10	PO11	PO12
CO1	3					1	1	1		1		1
CO2	3					1		1		1		1
CO3	3					1				1		1
CO4	3					2	1			1		1
CO5	3	2				1				1	3	1
CO6	3	3	3		1				2	1	3	1

Assessment Pattern

Bloom's Category	Continuous Assessment Tests		End Semester Examination
	1	2	
Remember	10	10	10
Understand	40	30	76
Apply		10	14
Analyse			
Evaluate			
Create			

Mark distribution

Total Marks	CIE (Marks)	ESE (Marks)	ESE Duration
150	50	100	3 hours

Continuous Internal Evaluation Pattern:

Attendance : 10 marks

Continuous Assessment Test (2 numbers) : 25 marks

Assignment/Quiz/Course project : 15 marks

End Semester Examination Pattern: There will be two parts; Part A and Part B. Part A contain 10 questions with 2 questions from each module, having 3 marks for each question. Students should answer all questions. Part B contains 2 questions from each module of which student should answer any one. Each question carries 14 marks and can have maximum 2 sub-divisions.

Course Level Assessment (Sample) Questions**CO1: Describe the properties of materials used in construction**

1. Write a short note on manufacturing process of cement.
2. Explain any three laboratory tests on cement and its IS specifications.
3. Write a note on quality of water used for concrete.
4. Explain the various types of admixtures and their uses.

CO2: Explain the properties of concrete and its determination

1. Explain briefly the manufacturing process of concrete.
2. Explain a method to assess the workability of concrete. Also highlight the merits and demerits of the test.
3. Explain the factors affecting bleeding and segregation of concrete.
4. Explain the various factors affecting strength of concrete.

CO3: Describe the various elements of building construction

1. Discuss the purpose of providing damp proof course.
2. Distinguish between plastering and pointing.
3. Explain the various types of pointing with neat sketches.
4. State the advantages and disadvantages of framed structures.

CO4: Explain the technologies for construction

1. Explain voided slab construction.
2. Describe the classification of scaffolding.
3. Explain slipform construction.
4. Discuss the general reasons of building failure.

CO5: Describe the procedure for planning and executing public works

1. Differentiate between earnest money deposit and security deposit.
2. Discuss the advantages of a lump sum contract over an item-rate contract.
3. Explain the life cycle of a construction project.
4. Explain the process of tendering for a construction project.

CO6: Apply scheduling techniques in project planning and control

1. The following details regarding a project are given.

Activity	A	B	C	D	E	F	G	H	I	J
Immediate Predecessor	-	A	A	B	B	C	C	D	E, F	G
Duration (Days)	5	2	6	4	4	2	3	8	7	2

- (a) Prepare an Activity on Node Diagram.

- (b) Find the expected duration of the project.
- (c) Determine the critical activities.
- (d) Compute the total and free float of all the activities.
2. For the project details given below:
- (a) Draw the network.
- (b) Prepare the schedule of activities
- (c) What is the project completion time?
- (d) Which is the critical path?
- (e) Determine the probability of completing the project in 55 days?

Activity	A	B	C	D	E	F	G	H	I
Predecessor	-	A	A	B	B	C	E	D,F	G,H
a	4	5	4	15	10	8	4	1	6
m	6	7	8	20	18	9	8	2	7
b	8	15	12	25	26	16	12	3	8

SYLLABUS

Module 1

Construction Materials

Timber products –properties and uses of veneer, plywood, fibre board, particle board, multi wood

Cement: Manufacturing, chemical composition, Tests on cement – specific gravity, standard consistency, initial and final setting time, fineness, soundness, compressive strength, IS specifications

Aggregates – types, Gradation, importance of gradation, bulking of fine aggregate

Quality of water for construction (Brief discussion only, Permissible limits of chemical constituents not required)

Admixtures, uses – mineral admixtures – fly ash and ground granulated blast furnace slag and chemical admixtures – plasticizers, super plasticizers, accelerators, retarders (brief discussion only)

Module 2**Concrete and Building Construction**

Process of manufacturing concrete – batching, mixing, transportation, placing, compacting, finishing, curing

Properties of fresh concrete: Workability, factors affecting workability, test on workability (slump test), segregation and bleeding (brief discussion)

Properties of hardened concrete: Strength, factors affecting strength, tests for strength of concrete in compression, tension and flexure

Lintels and arches: Types and construction details

Damp proof course (brief discussion only)

Finishing works: Plastering, pointing, painting – objectives and types

Structural systems – load bearing and framed construction, RCC and steel framed structures

Module 3**Construction Technology**

Cost-effective construction – rapid wall construction, soil-cement block masonry, voided slab technology, filler slab technology (brief discussion only)

Scaffolding – uses and classification (brief discussion only)

Formwork – requirements of good formwork, classification, slipform (brief discussion only)

Prefabricated construction – advantages and disadvantages, prefabricated building components.

Basic concept of prestressing – fundamental understanding of pre-tensioned and post-tensioned construction

Construction 3D printing (brief discussion only)

Building failures – general reasons

Causes of failures in RCC, steel and masonry structures

Module 4**Construction Project Management**

Construction projects, categories, life cycle of a project – pre-project phase, project phase, post-project phase, Detailed Project Report – contents

Tendering: types of tenders, stages in tendering

Contracts: types of contracts – item rate contract, lumpsum contract, percentage rate contract, turnkey contracts, concession contracts – BOT

Module 5

Construction Planning

Work break down structure

Types of Schedules – Construction schedule, Material schedule, labour schedule, equipment schedule, financial schedule

Bar chart, Mile Stone Charts

Networks, Network representation – Activity on Node (AoN) Diagram

Network analysis – Critical Path Method (CPM), Programme Evaluation and Review Technique (PERT) – concepts and problems

Text books:

1. Shetty M.S. and A. K. Jain (2019), Concrete Technology: Theory and Practice, S. Chand & Company Pvt. Ltd.
2. Varghese P. C. (2007), Building Construction, Prentice Hall India.
3. Punmia B. C., Ashok Kumar Jain and Arun Kumar Jain (2016), Building Construction, Laxmi Publications (P) Ltd.
4. Sharma S.C. and S.V. Deodhar (2019), Construction Engineering & Management, Khanna Book Publishing Co. (P) Ltd.
5. Kumar Neeraj Jha (2015), Construction Project Management: Theory and Practice, Pearson India Education Services Pvt.Ltd.

Reference books:

1. Sahu G. C. and Joygopal Jena (2015), Building Materials and Construction, McGraw Hill Education (India) Private Limited.
2. Gambhir M. L. (2004), Concrete Technology, Tata McGraw-Hill Publishing Company Limited.

3. Sharma S.K. (2019), Civil Engineering Construction Materials, Khanna Book Publishing Co. (P) Ltd.
4. Neville A.M. and Brooks J.J. (2010), Concrete Technology, Pearson Education Ltd.
5. Mehta P. K. and Paulo J. M. Monteiro (2014), Concrete-Microstructure, Properties and Materials, McGraw Hill Education.
6. Santhakumar R. (2006), Concrete Technology, Oxford Universities Press India.
7. Tony Bryan (2010), Construction Technology – Analysis and Choice, Wiley-Blackwell.
8. Joseph J. Moder, Cecil R. Philips and Edward W. Davis (1983), Project Management with CPM, PERT and Precedence Diagramming, Van Nostrand Reinhold Company Inc.
9. Charles Patrick (2012), Construction Project Planning and Scheduling, Dorling Kindersley India Pvt. Ltd.
10. Daniel W. Halpin and Bolivar A. Senior (2011), Construction Management, John Wiley and Sons Inc.

Lecture Plan

Module	Topic	Course Outcomes addressed	No. of Lectures
1	Module I (6 hours)		
1.1	Timber products –properties and uses of veneer, plywood, fibre board, particle board, multi wood	CO1	1
1.2	Cement – Manufacturing, chemical composition	CO1	1
1.3	Tests on cement – specific gravity, standard consistency, initial and final setting time, fineness, soundness, compressive strength, IS specifications	CO1	1
1.4	Aggregates – types, Gradation, importance of gradation, bulking of fine aggregate	CO1	1
1.5	Quality of water for construction (Brief discussion only, Permissible limits of chemical constituents not required) Admixtures, uses – mineral admixtures – fly ash and	CO1	2

	ground granulated blast furnace slag and chemical admixtures – plasticizers, superplasticizers, accelerators, retarders (brief discussion only)		
2	Module II (8 hours)		
2.1	Concrete manufacturing – batching, mixing, transportation, placing, compacting, finishing, curing	CO2	2
2.2	Properties of fresh concrete: Workability, factors affecting workability, test on workability (slump test), segregation and bleeding (brief discussion)	CO2	1
2.3	Properties of hardened concrete: Strength, factors affecting strength, tests for strength of concrete in compression, tension and flexure	CO2	1
2.4	Lintels and arches: Types	CO3	1
2.5	Damp proof course (brief discussion only), Finishing works: Plastering, pointing (objectives and types)	CO3	1
2.6	Painting (objectives and types)	CO3	1
2.7	Structural systems – load bearing and framed construction, RCC and steel framed structures	CO3	1
3	Module III (6 hours)		
3.1	Cost-effective construction – rapid wall construction, soil-cement block masonry, voided slab technology, filler slab technology (brief discussion only)	CO4	1
3.2	Scaffolding – uses and classification (brief discussion only)	CO4	1
3.3	Formwork – requirements of good formwork, classification, slipform (brief discussion only)	CO4	1
3.4	Prefabricated construction – advantages and disadvantages, prefabricated building components. Basic concept of prestressing – fundamental understanding of pre-tensioned and post-tensioned	CO4	1

	construction Construction 3D printing (brief discussion only)		
3.5	Building failures – general reasons Causes of failures in RCC, steel and masonry structures	CO4	2
4	Module IV (7 hours)		
4.1	Introduction to construction project management, construction projects, categories	CO5	1
4.2	Life cycle of construction project – pre-project phase, project phase, post-project phase, Detailed Project Report – contents	CO5	2
4.3	Tendering, types of tenders, stages in tendering	CO5	2
4.4	Contracts – types of contracts – item rate contract, lumpsum contract, percentage rate contract, turnkey contracts, concession contracts – BOT	CO5	2
5	Module V (8 hours)		
5.1	Introduction to construction planning and scheduling, Work break down structure	CO6	1
5.2	Types of Schedules: Construction schedule, Material schedule, labour schedule, equipment schedule, financial schedule	CO6	1
5.3	Bar chart, Mile Stone Charts	CO6	1
5.4	Introduction of networks, Network representation – Activity on Node (AoN) Diagram, Critical Path Method (CPM) – concepts and problems on determination of critical path, floats	CO6	3
5.5	Programme Evaluation and Review Technique (PERT) – concepts and problems	CO6	2

MODEL QUESTION PAPER

Reg.No.: _____

Name: _____

APJ ABDUL KALAM TECHNOLOGICAL UNIVERSITY**FIFTH SEMESTER B.TECH DEGREE EXAMINATION**

Course Code: CET309

Course Name: **CONSTRUCTION TECHNOLOGY AND MANAGEMENT**

Max. Marks: 100

Duration: 3 Hours

PART A*Answer all questions. Each question carries 3 marks.*

1. Explain bulking of fine aggregate.
2. State the IS specification for initial and final setting time of OPC.
3. Discuss the various objectives of plastering.
4. List the various requirements of an ideal paint.
5. Briefly describe rapid wall construction technology.
6. Explain 3D printing in construction.
7. Discuss the advantages and disadvantages of an item-rate contract.
8. Explain selective tendering.
9. Explain the three time estimates in PERT.
10. Illustrate the use of a material schedule in organizing construction activities at a site.

(10×3 marks = 30 marks)

PART B*Answer one full question from each module. Each full question carries 14 marks.***Module I**

11. a) Discuss the role of plasticizers in concrete. (6 marks)
- b) Differentiate between fibre board and particle board. (8 marks)

OR

12. a) Discuss the chemical composition of cement. (5 marks)
- b) Explain gradation of aggregates. Discuss the significance of gradation of aggregates. (9 marks)

Module II

13. a) Define workability of concrete. Explain the factors affecting workability. (5 marks)
 b) Explain any three laboratory tests on hardened concrete. (9 marks)

OR

14. a) Explain various types of arches with neat sketches. (8 marks)
 b) Distinguish between RCC framed and steel framed structures. (6 marks)

Module III

15. Explain the causes of failure in RCC structures. (14 marks)

OR

16. a) Discuss the advantages and disadvantages of prefabricated construction. (6 marks)
 b) Explain filler slab technology. (8 marks)

Module IV

17. Discuss the details included in the DPR of an infrastructure project. (14 marks)

OR

18. Explain the project formulation stage of a construction project. (14 marks)

Module V

19. For the given data, draw an AON network and determine the critical path. Also find the total float, free float and independent float of each activity.

Activity	A	B	C	D	E	F	G	H	I
Predecessor	-	A	A	C	B	B, D	C	F, G	E, H
Duration (days)	4	6	4	2	4	5	3	4	2

(14 marks)

OR

20. The table shows the details of various activities of a small project.

Activity	A	B	C	D	E	F	G	H	I	J
Predecessor	-	-	A	A	B	E	C	D, F	H	G
Optimistic	4	3	7	5	6	2	3		2	6

time (days)										
Most likely time (days)	6	5	8	7	7	3	4	9	4	8
Pessimistic time (days)	8	7	9	9	8	4	5	11	6	10

- Draw an AON network and calculate the project completion time with 50% probability.
- Find the probability of completing the project in (i) 30 days; (ii) 26 days.
- What project completion date has 80% chance of being met? (14 marks)

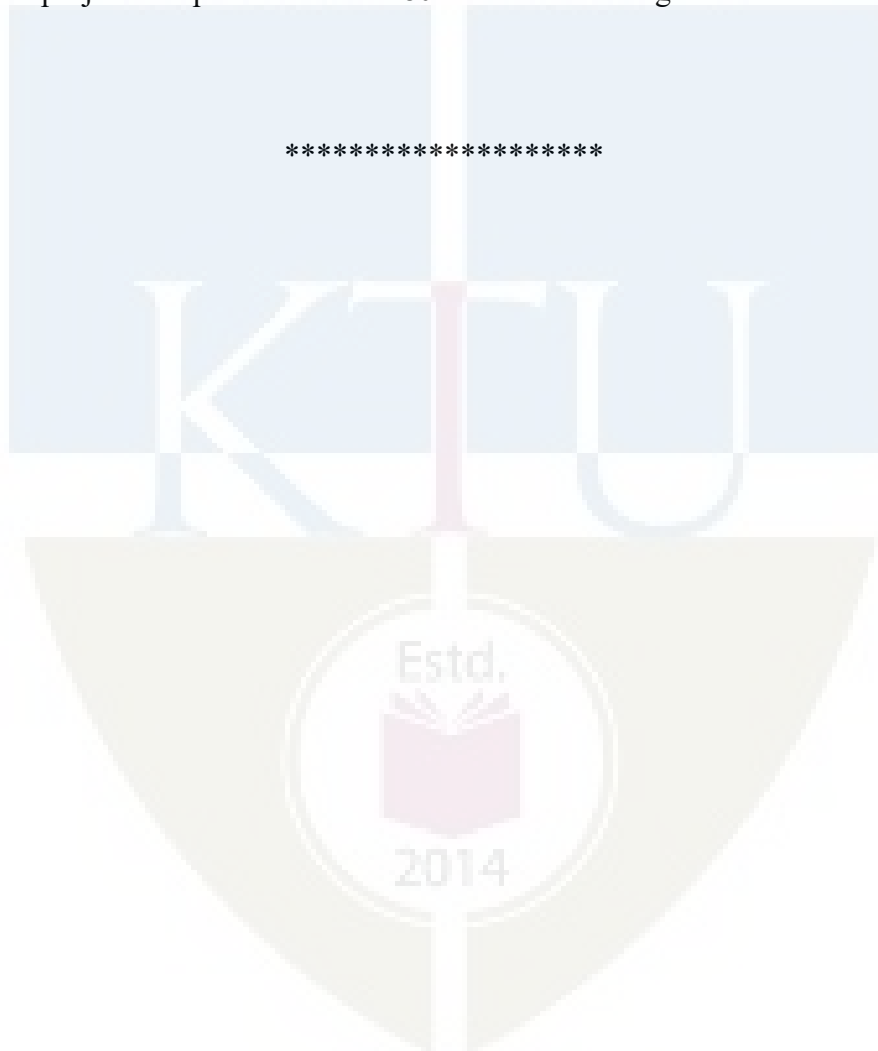

CEL331	MATERIAL TESTING LAB II	CATEGORY	L	T	P	CREDIT	YEAR OF INTRODUCTION
		PCC	0	0	3	3	2019

Preamble: The course aims to enrich the students to gain hands-on experience in conducting laboratory tests on various construction materials and thereby evaluate material quality and performance.

Prerequisite: Basics of Construction Engineering Materials.

General Instructions to Faculty:

1. Any 12 of the 15 experiments included in the list of experiments need to be performed mandatorily. Virtual Lab facility cannot be used to substitute the conduct of these mandatory experiments.
2. The laboratory should have possession of modern testing equipment such as Rebound hammer, ultrasonic pulse velocity, rebar locator, core cutter, concrete penetrometer and crack detection microscope at least for demonstration purposes.
3. Periodic maintenance and calibration of various testing instruments needs to be made.
4. Use of data visualization packages such as may be required for making various plots.

Course Outcomes: After the completion of the course, the student will be able to:

Course Outcome	Course Outcome Description
CO 1	To describe the basic properties of various construction materials
CO 2	Characterize the physical and mechanical properties of various construction materials.
CO3	Interpret the quality of various construction materials as per IS Codal provisions.

Mapping of course outcomes with program outcomes:

CO/PO	PO 1	PO 2	PO 3	PO 4	PO 5	PO 6	PO 7	PO 8	PO 9	PO 10	PO 11	PO 12
CO 1	3	2	2	2	1	3	-	-	2	2	-	2
CO 2	3	2	2	2	1	3	-	-	2	2	-	2
CO 3	3	2	2	2	1	3	-	-	2	2	-	2

Assessment Pattern:

Mark distribution

Total Marks	CIE	ESE	ESE Duration
150	75	75	2.5 hours

Continuous Internal Evaluation Pattern:

Attendance	:	15 marks
Continuous Assessment	:	30 marks
Internal Test (Immediately before the second series test)	:	30 marks

End Semester Examination Pattern: The following guidelines should be followed regarding award of marks

(a) Preliminary work	:	15 Marks
(b) Implementing the work/Conducting the experiment	:	10 Marks
(c) Performance, result and inference (usage of equipment and trouble shooting)	:	25 Marks
(d) Viva voce	:	20 marks
(e) Record	:	5 Marks

General instructions:

Practical examination to be conducted immediately after the second series test covering entire syllabus given below. Evaluation is a serious process that is to be conducted under the equal responsibility of both the internal and external examiners. The number of candidates evaluated per day should not exceed 20. Students shall be allowed for the University examination only on submitting the duly certified record. The external examiner shall endorse the record.

References

1. M.S.Shetty , Concrete Technology, Theory and Practice , S.Chand&Company, 2014
A.M.Neville and J.J Brooks, Concrete Technology,Second edition, Pearson.
2. **IS codes on cement:**IS 1489(Part 1& 2):1991 Specification for Portland pozzolana cement,IS 269:1989 – Specification for ordinary Portland cement, 33 grade,IS 8112 : 2013- Specification for ordinary Portland cement, 43 grade, IS 12269 : 2013- Specification for ordinary Portland cement, 53 grade,
3. **IS codes on aggregate:**IS 2386(Part 1):1963 Methods of test for aggregates for concrete: Part 1 Particle size and shape, IS 2386(Part 3):1963 Methods of test for aggregates for concrete: Part 3 Specific gravity, density, voids, absorption and bulking, IS 383:1970Specification for Coarse and Fine aggregate from natural sources of concrete
4. **IS codes on fresh and hardened concrete:** IS 1199:1959 Methods of sampling and analysis of concrete, IS 10262:2019 Concrete mix proportioning- Guidelines, IS 516:1959 Methods of tests for strength of concrete.
5. **IS codes on brick and tiles:**IS 3495 (Part 1 to 4):1992 Methods of tests of burned clay bricks,IS 1077:1992 Common burned clay building bricks (specification),IS 654:1992 Clay roofing tiles Mangalore pattern (specification).
6. IS 13311 (Part 1 & 2):1992Non - destructive testing of concrete-methods of test.

SYLLABUS

- Exercise 1. Testing of Cement: Fineness, normal consistency, initial & final setting time.
- Exercise 2. Testing of Cement: Specific gravity and compressive strength
- Exercise 3. Study on soundness of cement.
- Exercise 4. Testing of Coarse and Fine Aggregate: Sieve analysis.
- Exercise 5. Testing of Coarse and Fine Aggregate: Water absorption, bulk density, void ratio, porosity and specific gravity.
- Exercise 6. Test on bulking of sand.
- Exercise 7. Test on coarse aggregate crushing value
- Exercise 8. Tests on fresh concrete : Measurement of workability of concrete by slump cone test and compacting factor test.
- Exercise 9. Study on workability of concrete by Vee-Bee test and flow test.
- Exercise 10. Concrete mix design by IS code method and casting of cubes, cylinders with designed concrete mixes.
- Exercise 11. Tests on hardened properties of concrete: Compressive, split and flexural strength.
- Exercise 12. Tests on hardened properties of concrete: Modulus of elasticity of concrete
- Exercise 13. Tests on brick, floor and roof tiles as per IS codal provision.
- Exercise 14. Study on Non-destructive tests on hardened concrete (Rebound hammer, ultrasonic pulse velocity and Rebar locator).
- Exercise 15. Study on concrete core cutter, concrete penetrometer and crack detection microscope.

CEL 333	GEOTECHNICAL ENGINEERING LAB	CATEGORY	L	T	P	CREDIT	YEAR OF INTRODUCTION
		PCC	0	0	3	2	2019

Preamble:

Objective of the course is to familiarize students with the laboratory tests used to determine physical, index and engineering properties of geomaterials.

Prerequisite: CET 204 GEOTECHNICAL ENGINEERING I

Course Outcomes: After the completion of the course, the student will be able to:

CO1	Identify and classify soil based on standard geotechnical experimental methods.
CO2	Perform and analyze permeability tests.
CO3	Interpret engineering behavior of soils based on test results.
CO4	Perform laboratory compaction, CBR and in-place density test for fill quality control in the field.
CO5	Evaluate the strength of soil by performing various tests viz. direct shear test, unconfined compressive strength test and triaxial shear test.
CO6	Evaluate settlement characteristics of soils.

Mapping of course outcomes (COs) with program outcomes (POs)

COs/POs	PO1	PO2	PO3	PO4	PO5	PO6	PO7	PO8	PO9	PO10	PO11	PO12
CO1	3				1				2	2		
CO2	3				2				2	2		
CO3	3	2							2	2		
CO4	3				1				2	2		
CO5	3				2				2	2		
CO6	3	1			2				2	2		

Mark distribution

Total Marks	Continuous Internal Evaluation (CIE)	End Semester Examination (ESE)	End Semester Examination (ESE) Duration
150	75	75	2.5 hours

Continuous Internal Evaluation Pattern:

Attendance : 15 marks

Continuous Assessment : 30 marks

Internal Test (Immediately before the second series test) : 30 marks

End Semester Examination Pattern: The following guidelines should be followed regarding award of marks.

- a) Preliminary work : 15 marks
- b) Implementing the work/ Conducting the experiment : 10 marks
- c) Performance, result and inference (usage of equipments and trouble shooting) : 25 marks
- d) Viva voce : 20 marks
- e) Record : 5 marks

General instructions:

Practical examination to be conducted immediately after the second series test covering entire syllabus given below. Evaluation is a serious process that is to be conducted under the equal responsibility of both the internal and external examiners. The number of candidates evaluated per day should not exceed 20. Students shall be allowed for the University examination only on submitting the duly certified record. The external examiner shall endorse the record.

References

1. IS codes relevant to each test
2. C. Venkatramaiah, Geotechnical Engineering, New Age International publishers, 2012
3. Gopal Ranjan and A. S. R. Rao, Basic and Applied Soil Mechanics, New Age International Publishers, 2012
4. K. R. Arora, Soil Mechanics and Foundation Engineering, Standard Publishers, 2011

SYLLABUS

Part A

Estimation of physical and index properties of the given soil: After performing the set of experiments, students are expected to infer the results of the experiments in their engineering behavior.

1. Determination of Water Content and Specific Gravity
2. Sieve Analysis
3. Hydrometer/pipette Analysis
4. Atterberg Limits (Liquid Limit, Plastic Limit and Shrinkage Limit)
5. Swelling Test

6. Field Density determination

Part B

Determination of engineering properties of the given soil: Students should be familiarize with the tests to be performed to determine the engineering properties of the given soil and interpret the results for field application.

7. Permeability Test
8. Standard Proctor Compaction Test
9. Heavy compaction
10. California Bearing Ratio Test
11. Direct Shear test
12. Unconfined Compression Test
13. Consolidation Test

Study/demonstration

14. Triaxial test

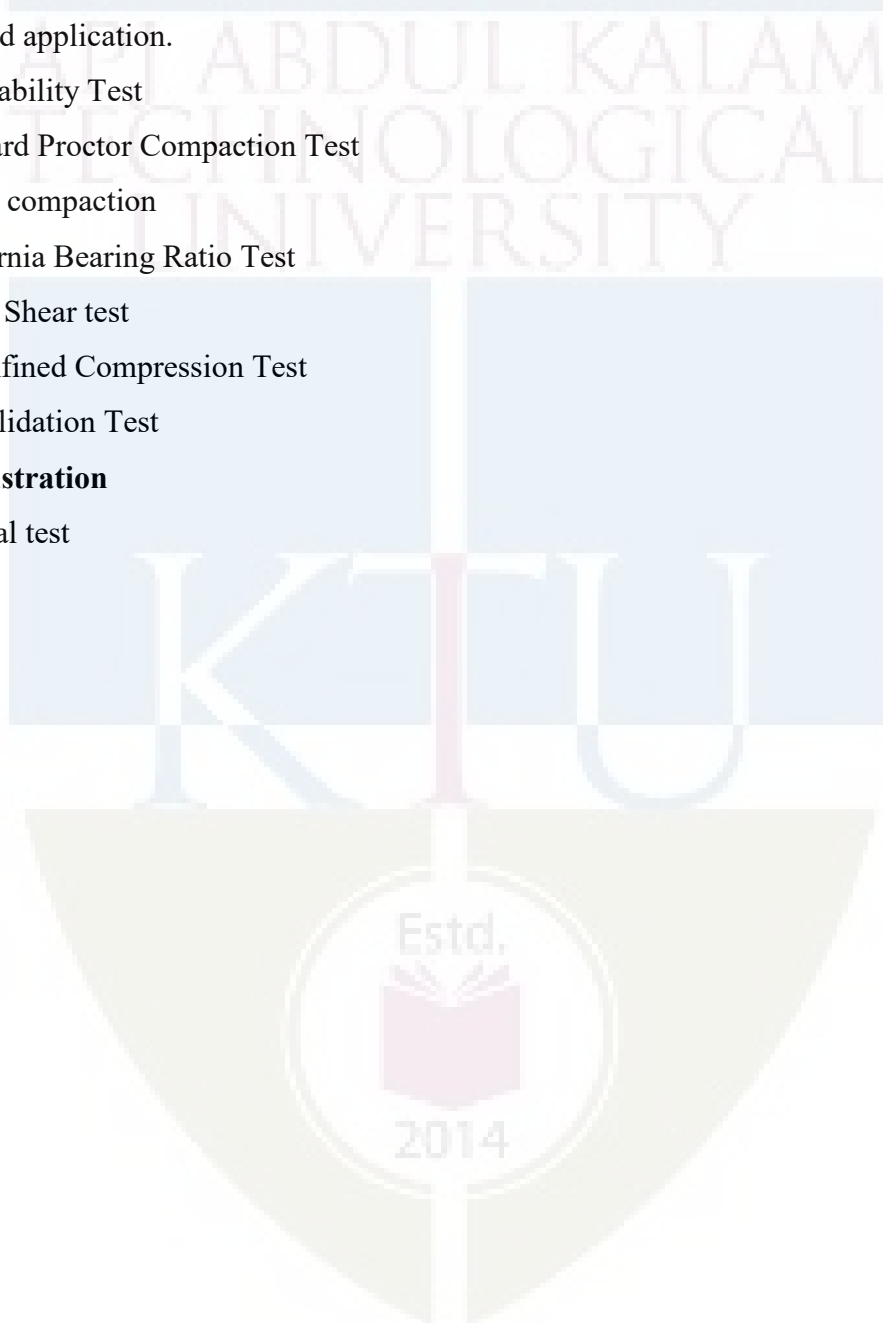

APJ ABDUL KALAM
TECHNOLOGICAL
UNIVERSITY

SEMESTER V

MINOR



Assessment Pattern

Bloom's Category	Continuous Assessment Tests		End Semester Examination
	1	2	
Remember/ Understand	20	20	30
Apply	30	30	70
Analyse			
Evaluate			
Create			

Mark distribution

Total Marks	CIE	ESE	ESE Duration
150	50	100	3 hours

Continuous Internal Evaluation Pattern:

Attendance	: 10 marks
Continuous Assessment Test (2 numbers)	: 25 marks
Assignment/Quiz/Course project	: 15 marks

End Semester Examination Pattern: There will be two parts; Part A and Part B. Part A contain 10 questions with 2 questions from each module, having 3 marks for each question. Students should answer all questions. Part B contains 2 questions from each module of which student should answer any one. Each question carries 14 marks and can have maximum 2 sub-divisions.

Course Level Assessment (Sample) Questions

CO1: Recall the fundamental terms/theorems associated with mechanics of linear elastic deformable bodies and explain the behavior/response of various structural elements under various loading conditions.

1. Explain Hooke's law.
2. Sketch the stress-strain curve of mild steel and mark the salient points
3. Explain the concept of BM and SF in beams, with the help of a cantilever beam subjected to uniformly distributed load over the whole span.
4. What is pure bending? Give an example.
5. What is point of contraflexure?
6. Explain (i) Section modulus and (ii) Moment of resistance

7. Distinguish between statically determinate and statically indeterminate structures.
8. What is degree of static indeterminacy? Explain with an example.
9. Explain (i) distribution factor and (ii) carry over moment.
10. Compare slope-deflection and moment distribution methods.

CO2: Calculate the stresses/strains in structural elements subjected to axial load and bending/twisting moments.

1. A 32 mm diameter steel bar is subjected to forces as shown in figure. Find the value of P necessary for equilibrium and stresses in different segments. Also calculate the final length of the bar. Take $E = 200$ GPa.

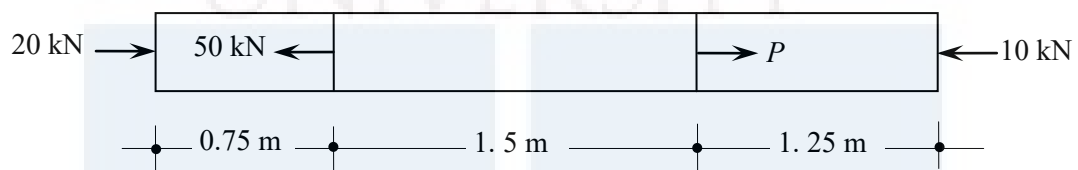

2. A strut and cable assembly ABC, shown in figure supports a vertical load $P = 10$ kN. The cable has an effective cross sectional area of 120 mm^2 and the strut has an area of 200 mm^2 . Calculate the normal stresses induced in the cable and the strut and indicate whether they are tension or compression. If the cable elongates 1.15 mm and the strut shortens 0.58 mm find the strains also.

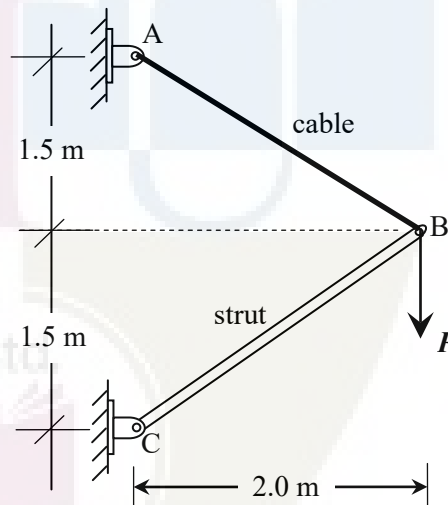

3. A tension test is carried out on a mild steel bar of 10 mm diameter. The bar yields under a load of 20 kN, it reaches a maximum load of 40 kN and breaks at 25 kN. The diameter of the bar at breaking was found to be 7 mm. The increase in length of the bar over a gauge length of 50 mm was found to be 0.029 mm under a load of 10 kN. Estimate (a) Young's modulus, (b) yield strength, (c) ultimate strength and (d) actual breaking strength.
4. A steel flat 25 mm wide and 6 mm thick is required to be bend into a circular arc of radius 10 m. Find the bending moment required to bend the flat. Also find the maximum stress induced. Take $E = 200$ GPa.

5. A steel box section $100 \text{ mm} \times 150 \text{ mm}$ with thickness 5 mm is used as a cantilever beam of span 2 m . If the beam carries a load of 1 kN at the free end, find the maximum bending stress at the mid span and the support. Neglect weight of the beam.
6. A timber beam $150 \text{ mm} \times 200 \text{ mm}$ is used as a simply supported beam of span 3 m . Find the maximum load that can be applied at 1 m from one of the supports, if the maximum bending stress in the beam is not to exceed 8 N/mm^2 . Neglect self weight of beam.
7. A beam of I section 400 mm deep has flanges 200 mm wide and 20 mm thick and web 15 mm thick. Compare its moment of resistance with that of a beam of rectangular section of the same weight, the depth being twice its breadth.
8. A solid circular shaft of diameter 50 mm is subjected to a torque. If the maximum shear stress induced in the shaft is 70 MPa , find the torque applied. If the modulus of rigidity of the material of the shaft is 80 GPa , find the angle of twist per meter length of the shaft.

CO3: Analyse statically determinate beams and trusses to determine the internal forces.

1. Draw the SFD and BMD of the beam shown.

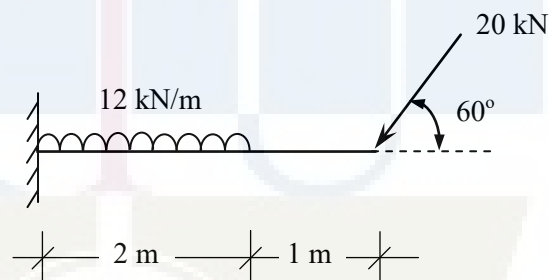

2. Draw SFD and BMD. Find the maximum BM also.

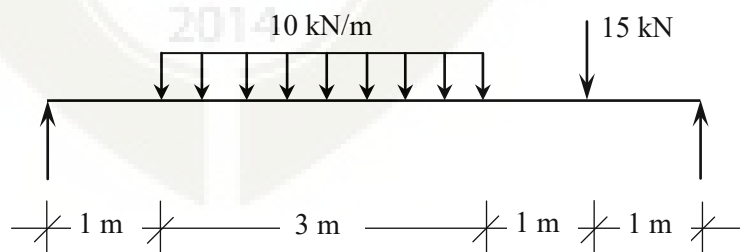

3. Analyse the truss by method of joints and determine the forces in all members.

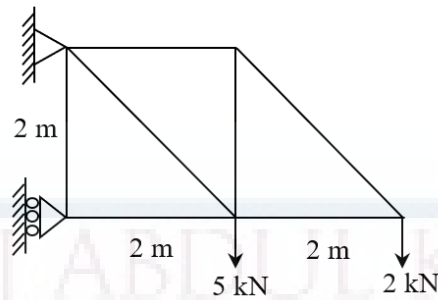

4. Analyse the truss by method of sections and determine the forces in members X, Y and Z.

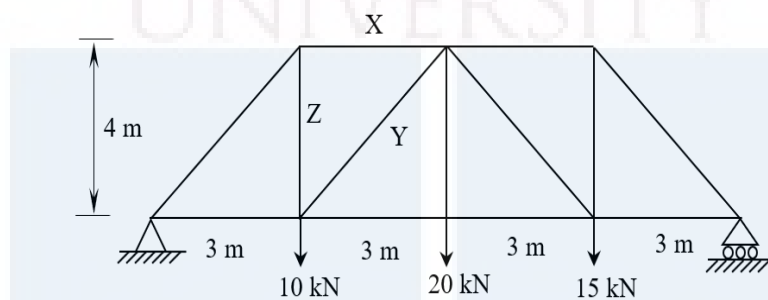

CO4: Determine the deflection of statically determinate beams.

1. A cantilever beam of span 3 m carries a point load of 10 kN at the free end along with a udl of 5 kN/m covering a distance of 2 m starting from the support. Find the maximum deflection of the beam. Take $EI = 3500 \text{ kNm}^2$.
2. Find the slope and deflection at the free end of the cantilever beam loaded as shown. Flexural rigidity (EI) of the beam may be assumed to be constant.

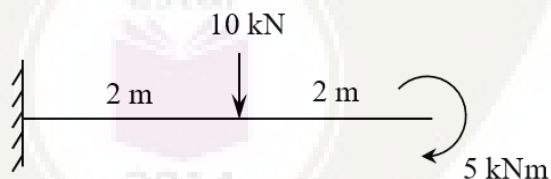

3. A simply supported beam of span 5 m carries a concentrated load of 20 kN at a distance of 2 m from the left support. Find the slope at supports and deflection under the load. Also find the maximum deflection and its location. Flexural rigidity of the beam is 2200 kNm^2 .
4. A simply supported beam of span 4 m carries a udl of 10 kN/m covering half the span starting from the left support. Find the slope at supports and maximum deflection. Locate the point of maximum deflection also. Flexural rigidity of the beam is 1500 kNm^2 .

CO5: Analyse statically indeterminate beams and frames.

1. Analyse the propped cantilever beam shown by consistent deformation method and draw BMD and SFD.

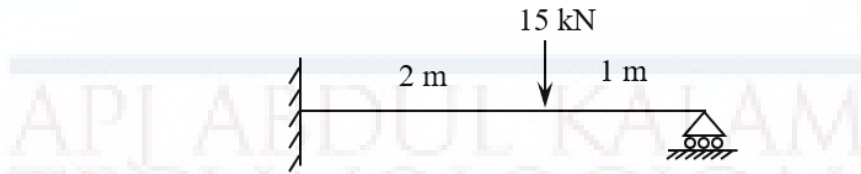

2. Analyse the continuous beam by slope deflection method and draw BMD.

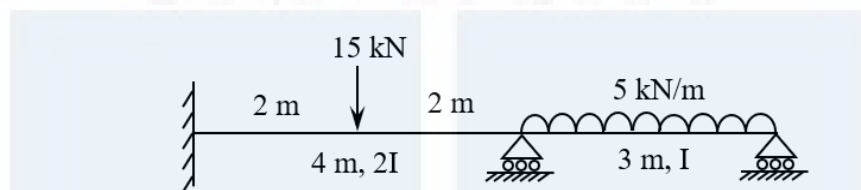

3. Analyse the frame by slope deflection method and draw BMD.

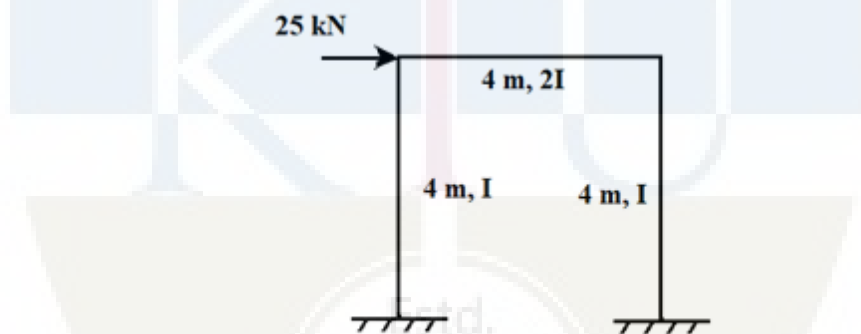

4. Analyse the frame shown in Question 2 using moment distribution method and draw BMD.
5. Analyse the continuous beam shown using moment distribution method and draw BMD.

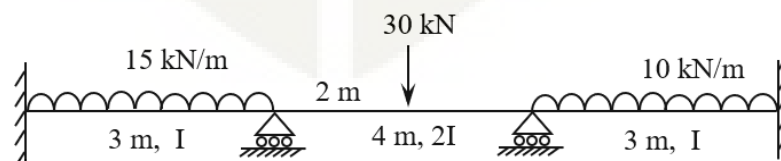

SYLLABUS**Module – 1**

Review of statics, Concept of stress and strain – types, Stress – strain relation - Hooke's law, Young's modulus of elasticity.

Axially loaded bars with uniform cross section–stress, strain and deformation.

Deformation of axially loaded bars with varying cross section and bars with varying axial loads.

Torsion of circular shafts – stress and deformation, Power transmitted by circular shafts.

Module – 2

Analysis of truss – method of joints and method of sections.

Beams – different types. Types of loading on beams. Concept of bending moment and shear force.

Shear force and bending moment diagrams of cantilever beams and simply supported beams for different type of loads.

Module – 3

Theory of simple bending, assumptions and limitations.

Calculation of normal stress in beams, moment of resistance

Shear stress in beams (concept only).

Moment-curvature relation. Deflection of beams by successive integration.

Macaulay's method - Deflection of cantilever beams and simply supported beams.

Module – 4

Statically indeterminate structures, degree of static and kinematic indeterminacy.

Fixed beam – fixed end moments for simple cases of loading (No analysis required).

Method of consistent deformation - Analysis of propped cantilever beam and continuous beams with maximum two redundants.

Module – 5

Slope deflection method – Analysis of continuous beams with maximum two unknowns, effect of support settlement. Analysis of frames with sway.

Moment distribution method – analysis of continuous beams and frames without sway.

Text Books:

1. Egor P. Popov, Engineering Mechanics of Solids, Prentice Hall International Series.
2. James M Gere, S.P. Timoshenko, Mechanics of Materials, CBS Publishers and Distributors, New Delhi.

- R. K. Bansal, A Text book of Strength of Materials, Laxmi Publications (P) Ltd, New Delhi.

References:

- R.C. Hibbeler, Structural Analysis, Pearson.
- Devdas Menon, Structural Analysis, Narosa Publications.
- H. J. Shah and S. B. Junnarkar, Mechanics of Structures Vol - I, Charotar Publishing House.
- S. Ramamrutham and R. Narayanan, Strength of Materials, Dhanpat Rai Publishing Co (P) Ltd.
- B. C. Punmia, Ashok K. Jain, Arun Kumar Jain, Mechanics of Materials, Laxmi Publications (P) Ltd, New Delhi.

Lecture Plan – Structural Mechanics

Module	Topic	Course Outcomes addressed	No. of Lectures
1	Module I: Total lecture hours: 9		
1.1	Review of statics – equilibrium conditions, free body diagrams, centroid, moment of inertia.	-	1
1.2	Concept of stress, types of stresses. Concept of strain, types of strains. Stress – strain relation - Hooke's law, Young's modulus of elasticity. Stress-strain ($\sigma - \epsilon$) diagram of mild steel.	CO1	1
1.3	Axially loaded bars with uniform cross section – calculation of stress, strain and deformation.	CO1, CO2	1
1.4	Deformation of axially loaded bars with varying cross section. Stepped bars, deformation of axially loaded bars with varying axial loads	CO1, CO2	3
1.5	Torsion of circular shafts, assumptions, derivation of torsion equation. Variation of stress across the cross section. Polar modulus.	CO1	1
1.6	Calculation stress and deformation of circular shafts subjected to torsion. Power transmitted by circular shafts.	CO1, CO2	2
2	Module II: Total lecture hours:10		
2.1	Analysis of truss – Method of joints	CO1, CO3	2

2.2	Analysis of Truss – Method of sections	CO1, CO3	2
2.3	Beams – different types. Types of loading on beams. Concept of bending moment and shear force. Shear force and bending moment diagrams.	CO1, CO3	2
2.4	Shear force and bending moment diagrams of cantilever beams subjected to point load, uniformly distributed load, uniformly varying load and concentrated moment.	CO3	2
2.5	Shear force and bending moment diagrams of simply supported beams subjected to point load and uniformly distributed load.	CO3	2
3	Module III : Total lecture hours : 9		
3.1	Theory of simple bending – derivation of equation, assumptions and limitations.	CO1, CO2	1
3.2	Calculation of normal stress in beams, moment of resistance. Problems involving bending stress. Shear stress in beams (concept only)- variation of shear stress across the cross section.	CO1, CO2	2
3.3	Moment-curvature relation. Basic differential equation for calculating the deflection of beams. Calculation of deflection by successive integration. Principle of superposition.	CO1, CO4	2
3.4	Macaulay's method - Deflection of cantilever beam subjected to point load and uniformly distributed loads.	CO1, CO4	2
3.5	Macaulay's method - Deflection of simply supported beams subjected to point load and uniformly distributed loads. Clerk Maxwell's theorem of reciprocal deflection	CO1, CO4	2
4	Module IV: Total lecture hours:8		
4.1	Statically indeterminate structures, degree of static and kinematic indeterminacy - examples Force and displacement method of analysis (concept only)	CO1	1
4.2	Fixed beam – fixed end moments for simple cases of loading (No analysis required). BMD of fixed beam, point of contraflexure.	CO1, CO3	2
4.3	Method of consistent deformation - Analysis of propped cantilever beam.	CO1, CO5	2

4.4	Method of consistent deformation – analysis of beams with maximum two redundants.	CO1, CO5	3
5	Module V: Total lecture hours:9		
5.1	Slope deflection method – equation (no derivation required). Analysis of continuous beams with maximum two unknowns.	CO1, CO5	2
5.2	Slope deflection method – analysis of continuous beam with support settlement.	CO1, CO5	1
5.3	Slope deflection method – analysis of frames with sway.	CO1, CO5	2
5.4	Moment distribution method – concept. Distribution factor and carry over moment.	CO1, CO5	1
5.5	Moment distribution method – analysis of continuous beams.	CO1, CO5	1
5.6	Moment distribution method – analysis of frames without sway.	CO1, CO5	2

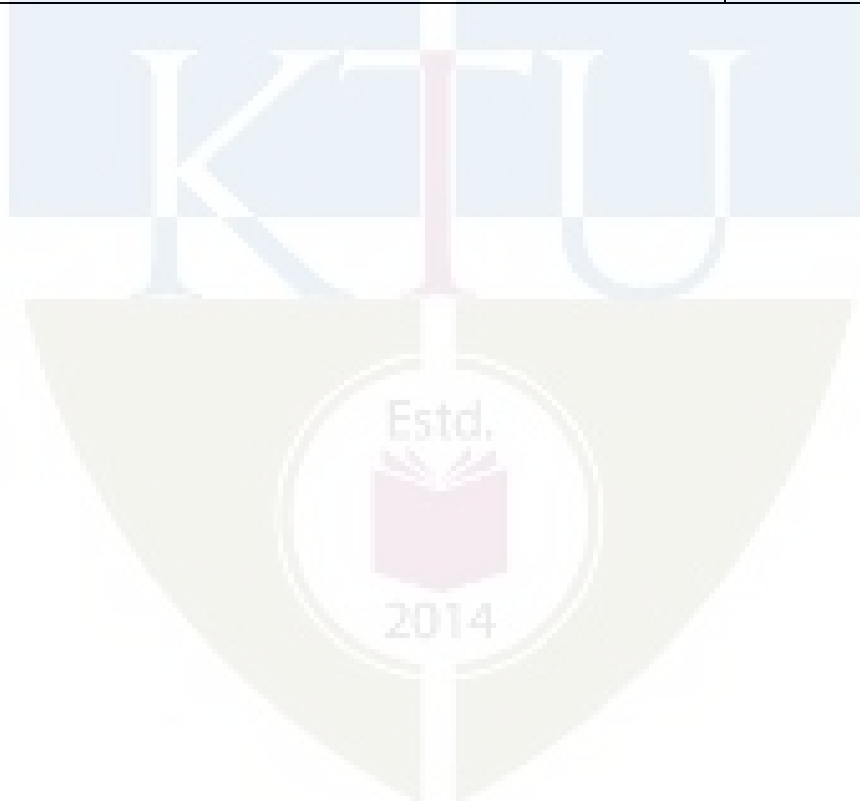

MODEL QUESTION PAPER

Reg. No.: _____

Name: _____

APJ ABDUL KALAM TECHNOLOGICAL UNIVERSITY
FIFTH SEMESTER BTECH DEGREE EXAMINATION

Course Code: CET381

Course Name: STRUCTURAL MECHANICS

Max. Marks: 100

Duration: 3 Hours

PART A

Answer all questions; each question carries 3 marks.

1. a) Sketch the stress-strain graph of mild steel and mark the salient points.
- b) A steel bar of length 1 m and diameter 12 mm was found to elongate by 0.64 mm under an axial load of 15 kN. Find the stress induced and modulus of elasticity of the material.
- c) What is the advantage of method of sections over method of joints in the analysis of trusses?
- d) What is the relationship between SF and BM? Illustrate with a simple example.
- e) What is pure bending? Give an example.
- f) Using successive integration method, find the deflection at the free end of a cantilever beam carrying a point load at the free end.
- g) Explain 'static indeterminacy' and 'kinematic indeterminacy' with a suitable example.
- h) Write down the consistent deformation equations for a beam with degree of static indeterminacy = 2. Explain the basic terms in the equation.
- i) What are the reasons for side sway in frames?
- j) Write notes on (i) distribution factor and (ii) carry over moment.

(10×3 marks = 30 marks)

PART B

Answer one full question from each module; each full question carries 14 marks.

Module I

2. A 32 mm diameter steel bar is subjected to forces as shown in figure. Find the value of P necessary for equilibrium and stresses in different segments. Also calculate the final length of the bar. Take $E = 200$ GPa.

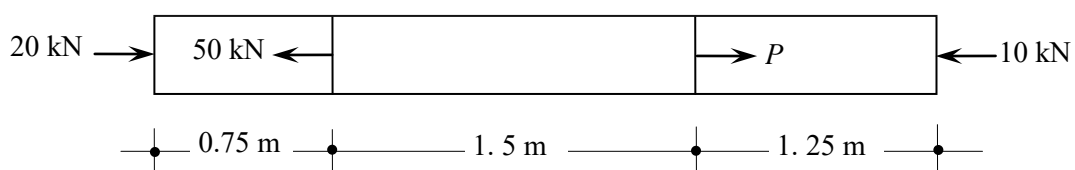

3. A tension test is carried out on a mild steel bar of 10 mm diameter. The bar yields under a load of 20 kN, it reaches a maximum load of 40 kN and breaks at 25 kN. The diameter of the bar at breaking was found to be 7 mm. The increase in length of the bar over a gauge length of 50 mm was found to be 0.029 mm under a load of 10 kN. Estimate (a) Young's modulus, (b) yield strength, (c) ultimate strength and (d) actual breaking strength.

Module II

4. Draw the SFD and BMD of the beam loaded as shown in figure. Find the maximum BM and locate the point of maximum BM also.

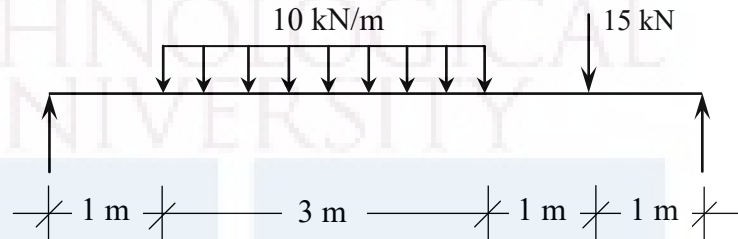

5. Analyse the truss by method of joints and determine the forces in all members.

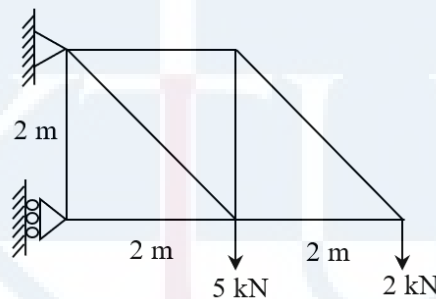

Module III

6. A beam of I section 400 mm deep has flanges 200 mm wide and 20 mm thick and web 15 mm thick. Compare its moment of resistance with that of a beam of rectangular section of the same weight, the depth being twice its breadth.
7. A simply supported beam of span 4 m carries a udl of 10 kN/m covering half the span starting from the left support. Find the slope at supports and maximum deflection. Locate the point of maximum deflection also. Flexural rigidity of the beam is 1500 kNm^2 .

Module IV

8. a) Draw the BMD of a fixed beam carrying udl through out its span. (4 marks)
- b) Analyse the propped cantilever beam shown by consistent deformation method and draw BMD and SFD.

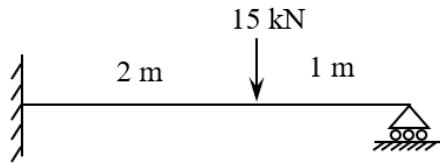

(10 marks)

9. Analyse the beam shown by consistent deformation method and draw BMD.

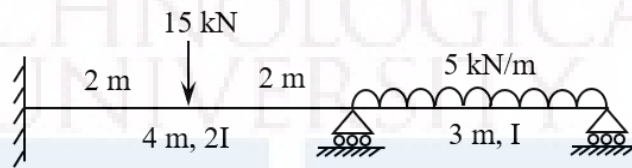

Module V

10. Analyse the frame by slope deflection method and draw BMD.

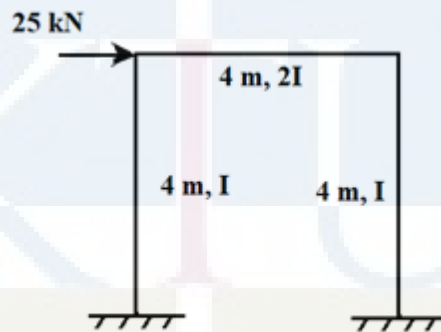

11. Analyse the continuous beam shown using moment distribution method and draw BMD.

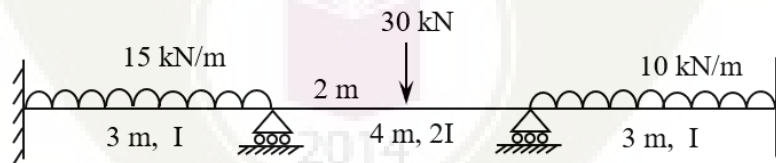

CET383	ECO-FRIENDLY TRANSPORTATION SYSTEMS	CATEGORY	L	T	P	CREDIT	YEAR OF INTRODUCTION
		VAC	3	1	0	4	2019

Preamble : Objective of the course is to introduce the principles and practice of sustainability on transportation systems and development of an eco-friendly transport system.

Prerequisite: Nil

Course Outcomes:

	Description
CO No.	At the end of the course, students will be able to:
CO 1	Apply the basic principles of sustainability to infrastructure related problems
CO 2	Analyse Transportation network for eco-friendliness and quantify the levels.
CO 3	Design eco-friendly transportation systems
CO 4	Apply concepts of sustainability in developing green fuels and vehicles.
CO 5	Design for sustainability in public transport, Applications of tools like GIS, GPS.

Mapping of course outcomes with program outcomes

	PO1	PO2	PO3	PO4	PO5	PO6	PO7	PO8	PO9	PO10	PO11	PO12	PSO1	PSO2
CO 1	2	2	2	1		1	3	1		2		1	2	3
CO 2	2	2	1	2	1	1	1	1	1	1		1	2	2
CO 3	2	1	3	1	2	1	1	1	2	2	1	2	2	3
CO 4	2	2	2	1	1	2	2	1	1	1	1	2	2	3
CO 5	1	3	3	3	3	3	2	2	3	3	2	2	2	3

Assessment Pattern

Bloom's Category	Continuous Assessment		End Semester Examination (marks)
	Test 1 Marks	Test 2 Marks	
Remember	7.5	7.5	30
Understand	7.5	7.5	30
Apply	-	-	-
Analyse	5	5	20
Evaluate	5	5	20
Create			

Mark Distribution

Total Marks	CIE (Marks)	ESE (Marks)	ESE Duration
150	50	100	3 hours

Continuous Internal Evaluation Pattern:

Attendance	: 10 marks
Continuous Assessment Test (2 numbers)	: 25 marks
Assignment/Quiz/Course Project	: 15 marks

End Semester Examination Pattern:

The question consists of two parts- Part A and Part B. Part A consists of 10 questions with 3 marks for each (two questions from each module). Part B consists of two questions from each module, out of which one has to be answered. Each question carries 14 marks and can have maximum 2 subdivisions.

Sample Course Level Assessment Questions:

- 1 Course Outcome 1 (CO1):** Define sustainability in transportation context. How can the principles be applied here?
- 2 Course Outcome 2 (CO2):** Describe the procedure of evaluating the performance of a transportation network, citing any example.
- 3 Course Outcome 3 (CO3):** What are the characteristics of eco-friendly transportation system? What changes are to be incorporated in designing the same?
- 4 Course Outcome 4 (CO4):** Discuss the concept of green vehicles describing the aspects that make them green.

5 Course Outcome 5 (CO5): Giving KSRTC as an example explain how sustainability can be achieved in public transport.

Syllabus

Module	Contents	Hours
1	Introduction to the concept of sustainability, basic principles.	10
2	Transport networks basics, Performance measures, Advanced transport systems	10
3	Design for eco-friendly Transportation, Professional praxis in sustainability, concept and applications	9
4	Emerging concepts in sustainable transportation: green vehicles and green roads	9
5	Sustainable public transport: Promoting public transport, Transit oriented development, integrated multi-modal transport.	7

Text Books

1. Chisty, J, Lall, K. Introduction to Transportation Engineering. PHI
2. O' Flaherty, C.A (Ed.), Transport Planning and Traffic Engineering, Elsevier.
3. Jeffrey Tumlin: Sustainable Transportation Planning: Tools for Creating Vibrant, Healthy, and Resilient Communities, John Wiley & Sons

References

1. Green Transportation Logistics: The Quest for Win-Win Solutions Editors: Psaraftis, Harilaos N. (Ed.), Springer
2. Thomas Abdallah: Sustainable Mass Transit: Challenges and Opportunities in Urban Public Transportation.
3. Chester Patton, Public Transit Operations: The Strategic Professional
4. Sustainable and Efficient Transport: Incentives for Promoting a Green Transport Market- Edited by Ellen Eftestøl-Wilhelmsson, et al, Edward Elgar
5. Rani Iyer: Green Transport: Exploring Eco-Friendly Travel for a Better Tomorrow:
6. Smart City project reports.
7. Environmental Impact Assessment Reports on Infrastructure projects.

Course Content and lecture Schedule:

No.	Topic	Course Outcome	No. of Hrs
1	Module 1		Total: 10
1.1	Sustainability: Definition, concepts	CO1	2
1.2	Environmental impacts of infrastructure projects, depletion of natural resources and pollution.	CO1	2
1.3	Problems of present transportation systems, performance analysis. Introduction to eco-friendly systems.	CO1	6
2	Module 2		Total: 10
2.1	Transportation network basics: network planning, design, operation and management (elementary ideas only)	CO2	3
2.2	Measures of network performance, factors and parameters.	CO2	4
2.3	Introduction to advanced transport systems: metro, monorail, maglev, hyperloop.	CO2	3
3	Module 3		Total: 7
3.1	Eco-friendly transport: Necessity, Basics: reducing natural fuels	CO3	2
3.2	Eco-friendly transport network. Parameters, design, implementation.	CO3	3
3.3	Professional praxis in sustainability: concepts, practical applications. Paradigm shift: Mobility and accessibility.		2
4	Module 4		Total: 9
4.1	Emerging concepts in sustainable transportation: green vehicles and green roads: basics and necessity.	CO4	2
4.2	Green vehicles: minimizing fuel consumption, alternate fuels. Green pathways: sustainable design, construction,	CO4	4
4.3	Forgiving designs for safety, ITS applications.	CO4	3
5	Module 5		Total: 9
5.1	Sustainable public transport: Promoting public transport, Fleet management and scheduling: Concepts and tools only.	CO5	3
5.2	Transit oriented development (smart cities), integrated multi-modal transport, GIS applications.	CO5	6

5.3	Micro projects: i) Compilation of studies on green fuels and transport, with comparison. ii) A study on literature available on a typical smart city project, in the transport context, and propose designs. (may be given as assignments)		
-----	--	--	--

Model Question Paper

**APJ ABDUL KALAM TECHNOLOGICAL UNIVERSITY
FIFTH SEMESTER B. TECH DEGREE EXAMINATION, MONTH & YEAR**

Course Code: CET383

Course Name: **Eco-friendly Transportation Systems (Minor)**

Marks:100 Duration: 3 hrs

PART A

(Answer all questions. Each question carry three marks)

1. Define sustainability with emphasis on transport.
2. List the principles of sustainability.
3. What are the fundamental elements of a transport network? How do they contribute to performance?
4. Compare metro and maglev technologies.
5. Why is an eco-friendly transport necessary? Cite a typical example.
6. Why is a paradigm shift necessary in sustainability?
7. Explain the terms: Green roads, Green fuels.
8. With a typical example, explain forgiving designs.
9. List a few methods of promoting public transport.
10. What do you understand from Transit Oriented Development?

PART B

(Answer one full question from each module)

11. a) Describe how an infrastructure project affects environment. (10)
 b) What are the issues with present transport systems? (4)

OR

- 12 a) When is a system deemed eco-friendly? Explain in transport context. (6)

b). What are the parameters of performance analysis of transportation systems? Explain (8)

13 a) With a typical example, illustrate the performance evaluation of a transport network(6)

b) What is hyperloop? Is it eco-friendly? How? (8)

OR

14a) Describe the process of network planning, design, operations and management (10)

b) What are the challenges faced by metro rail systems? (4)

15a) Explain the principles of an eco-friendly transport network (8)

b)Discuss the term professional praxis in a sustainability scenario. (6)

OR

16 a) How is the eco-friendliness of a transport network evaluated? Discuss the steps involved(8)

b)Explain the factors involved in designing an eco-friendly network (6)

17 a) List the alternate fuels for transport and discuss any two (6)

b) Define ITS. What are its application in eco-friendly transport. Expalin any two. (8)

OR

18 a) Discuss any two eco-friendly construction methods for roads (8)

b) What are the methods of reducing fuel consumption in vehicles (6)

19a)Write a note on public transport fleet management. (6)

b) /what is meant by integrated multi-modal transport? Discuss it's possibilities in a city in Kerala. (8)

OR

20 Discuss the applications of GIS and GPS in transport, explaining how eco-friendliness can be achieved. (14)

Estd.



2014

CET 385	SUSTAINABILITY ANALYSIS AND DESIGN	CATEGORY	L	T	P	CREDIT	Year of Introduction
		VAC	4	0	0	4	2019

Preamble: Goal of this course is to introduce various tools and techniques of sustainability analysis and its significance in design and engineering decision making.

Prerequisite: Nil

Course Outcomes: After completion of the course the student will be able to:

Course outcome identifier	Description of course outcome	Prescribed learning level
CO 1	Identify the impacts of various materials and processes on the biosphere	Remembering
CO2	Identify the parameters used in the calculation of sustainability	Understanding
CO 3	Estimate sustainability metrics for application-material combinations.	Applying
CO 4	Apply the design approaches by integrating sustainability concepts	Applying

Mapping of course outcomes with program outcomes (Minimum requirement)

	PO 1	PO 2	PO 3	PO 4	PO 5	PO 6	PO 7	PO 8	PO 9	PO 10	PO 11	PO 12
CO 1	1	-	-	-	-	-	-	-	-	-	-	-
CO 2	1	2	-	-	-	-	-	-	-	-	-	-
CO 3	2	3	2	-	2	-	-	-	-	-	-	-
CO 4	2	3	2	-	2	-	-	-	-	-	-	-
CO5												

Assessment Pattern

Bloom's Category	Continuous Assessment Tests		End Semester Examination (Marks)
	Test 1 (Marks)	Test 2 (Marks)	
Remember	7.5	7.5	30
Understand	7.5	7.5	30
Apply	10	10	40
Analyse			

Evaluate			CIVIL ENGINEERING
Create			

Mark Distribution

Total Marks	CIE (Marks)	ESE (Marks)	ESE Duration
150	50	100	3 hours

Continuous Internal Evaluation Pattern:

Attendance	: 10 marks
Continuous Assessment Test (2 numbers)	: 25 marks
Assignment/Quiz/Course Project	: 15 marks

End Semester Examination Pattern:

There will be two parts: Part A and Part B.

Part A contains 10 questions with 2 questions from each module and each question shall carry 3 marks. Students should answer all questions.

Part B contains 2 questions from each module of which student should answer any one. Each question carries 14 marks and can have maximum 2 sub-divisions

Course level Assessment Questions

Course Outcome 1 -Identify the impacts of various materials and processes on the biosphere.

1. How are materials classified as renewable and non-renewable?
2. Compare infinitely available and regenerative renewable resources.
3. Prepare a short description on zero waste production system.

Course Outcome 2 -Identify the parameters used in the calculation of sustainability

1. Compare “output pulled” and “input pushed” systems
2. Prepare short note on “dematerialization” and “remanufacturing”.
3. Explain ecological footprint

Course Outcome 3 -Estimate sustainability metrics for application-material combinations

1. Illustrate the significance of biomimicry taxonomy in sustainable design.
2. How is global warning potential assessed?
3. Illustrate water foot print of a process.

Course Outcome 4 - Apply the design approaches by integrating sustainability concepts

1. Illustrate the role of biomimicry in the design for sustainability approaches.
2. Explain the significance of “cradle to cradle” design concept.

3. List any five commonly used life cycle impact categories

Syllabus

Module 1

Introduction to sustainability - Sustainable use of materials: Energy, ecology and natural resources

Engineering design process-Role of materials in design: important material characteristics, construction ecology and metabolism - specifications and market.

Module 2

Material flow analysis - efficiencies in mass flow — Constructing a material flowsystem—embodied energy—engineering models based on waste and materials management

Module 3

Sustainability metrics — mass balance and footprint concept Sustainable design - Specifications for sustainable material use — waste management and material life cycles - Environmentally sensitive design — Green engineering

Module 4

Life-cycle assessment—Life cycle assessment framework-Inventory analysis —impact assessment – interpretation

Module 5

Sustainable designs approaches - Sustainable urbanization – sustainable cities –sustainable transport - energy efficiency.

Text Books:

1. Allen,D.TandShornard,DR,SustainabilityEngineering,Concepts,DesignandCase Studies, Prentice Hall.
2. BradleyA.S.,Adebryo,A.O.,MariaP,EngineeringApplicationsinSustainableDesignand Development, Cengage Learning

References:

1. UNDP (1987), Our Common Future, Report of the World Commission on Environment and Development
2. Riley,D.R.,Thatche,C.E.,andWorkman,E.A.(2006),Developingandapplyinggreen building technology in an indigenous community: An engaged approach to sustainability education,InternationalJournalofSustainabilityinHigherEducation,7(2),142-157.
3. LSF-LST (2007). Understanding Sustainability, Learning for a Sustainable Future, <http://www.lsfst.cz/en/teachers/understanding.php>,YorkUniversity,Ontario,Canada.
4. ASCE (2004), Sustainable Engineering Practice: An Introduction, Jorge A. Vanegas(Editor).

5. USGBC (2008), LEEA Rating Systems, US Green Building Council, <http://www.usgbc.org/DisplayPage.aspx?CMSPageID=222>(2008), Thematic Strategy on the prevention and recycling of waste, The European Commission, <http://ec.europa.eu/environment/waste/index.htm>

Course Contents and Lecture Schedule:

No.	Topic	Course Outcome	No. of Hrs
1	Module 1		Total: 9
1.1	Introduction to sustainability - Sustainable use of materials	CO1, CO2	2
1.2	Energy, ecology and natural resources	CO1, CO2	3
1.3	Engineering design process-Role of materials in design	CO1, CO2	2
1.4	Construction ecology and metabolism - specifications and market	CO1, CO2	2
2	Module 2		Total: 9
2.1	Material flow analysis - efficiencies in mass flow	CO1, CO2 CO3	3
2.2	Constructing a material flowsystem—embodied energy	CO1, CO2 CO3	3
2.3	Embodied energy	CO2, CO3	1
2.4	Engineering <i>models</i> based on waste and materials management	CO2, CO3	2
3	Module 3		Total: 9
3.1	Sustainability metrics — mass balance and footprint concept Sustainable design	CO1, CO2 CO3, CO4	2
3.2	Specifications for sustainable material use	CO1, CO2 CO3, CO4	3
3.3	Waste management and material life cycles	CO3, CO4	2
3.4	Environmentally sensitive design — Green engineering	CO3, CO4	2
4	Module 4		Total: 9
4.1	Life-cycle assessment—Life cycle assessment framework	CO1, CO2 CO3, CO4	3
4.2	Inventory analysis	CO1, CO2 CO3, CO4	3
4.3	impact assessment – interpretation	CO1, CO2 CO3, CO4	3
5	Module 5		Total: 9
5.1	Sustainable designs approaches	CO1, CO2 CO3, CO4	3
5.2	Sustainable urbanization – sustainable cities	CO1, CO2 CO3, CO4	3
5.3	Sustainable transport - energy efficiency.	CO3, CO4	3

QP CODE:

Reg No.: _____

Name: _____

ABDUL KALAM TECHNOLOGICAL UNIVERSITY
FIFTH SEMESTER B.TECH DEGREE EXAMINATION, MONTH & YEAR

Course Code: CET 385

Course Name: SUSTAINABILITY ANALYSIS AND DESIGN

Max. Marks: 100

Duration: 3 hours

Answer All Questions- 10 ×3 =30marks

Each question carries 3marks

1. Narrate any one material characteristic that is needed to ensure sustainability.
2. Highlight any one approach that could enable products in the market to be preferred on environmental performance.
3. State any one of the observation from material flow analysis that would supplement sustainability evaluation.
4. What is embodied energy of a material?
5. Define footprint based sustainability indicators.
6. Illustrate the term “Reuse factor”
7. Additive operations in LCA
8. LCA helps to arrive at lower entropy form of a material. Substantiate the statement giving any one reason.
9. Prepare a short account on sustainable urbanization
10. How is energy efficiency linked with sustainable design process.

PART B

Each question carries 14marks

11. Identify any three engineering materials that are used as environmental substitutes for the conventional systems. Also narrate the factors considered in their selection based on engineering design requirement.
- or
12. Explore the possibility of creating ecosystem based approach for construction process and highlight its significance to ensure sustainability.
- or
13. “Buildings embody large quantity of material energy”. Prepare a short description narrating how this resource could be used to create energy efficient material use road map for Kerala.
- or
14. Establish the industrial ecological model as an outcome of engineering models proposed for waste and material management.

15. Explore the possibility of creating ecosystem based approach for construction process and highlight its significance to ensure sustainability. Case based justification is expected.

or

16. Explain a few interventions incorporated as part of design for environment concept for improving the material handling process.

17. Explain the four major steps involved in the LCA programme.

or

18. (i) List any two challenges faced while implementing the LCA for an impact assessment programme.

(ii) Justify ,giving two reasons, how LCA enables to take environmentally informed decisions

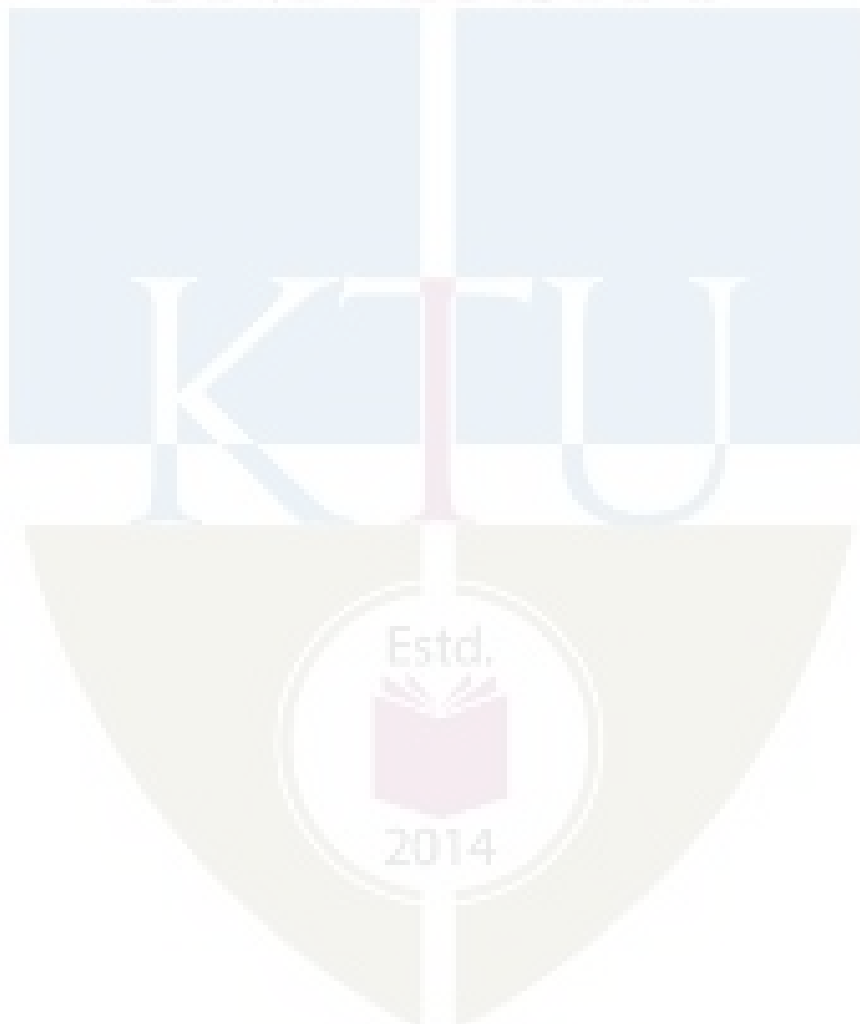

APJ ABDUL KALAM
TECHNOLOGICAL
UNIVERSITY

SEMESTER V

HONOURS



Bloom's Category	Continuous Assessment Tests		End Semester Examination
	1	2	
Remember/ Understand	15	15	30
Apply	35	35	70
Analyse			
Evaluate			
Create			

Mark distribution

Total Marks	CIE	ESE	ESE Duration
150	50	100	3 hours

Continuous Internal Evaluation Pattern:

Attendance : 10 marks

Continuous Assessment Test (2 numbers) : 25 marks

Assignment/Quiz/Course project : 15 marks

End Semester Examination Pattern: There will be two parts; Part A and Part B. Part A contain 10 questions with 2 questions from each module, having 3 marks for each question. Students should answer all questions. Part B contains 2 questions from each module of which student should answer any one. Each question carries 14 marks and can have maximum 2 sub-divisions.

Course Level Assessment (Sample) Questions

CO1: Explain the basic terms and principles associated with structural dynamics.

1. State and explain D'Alembert's principle.
2. How do you model a system for dynamic analysis?
3. What are the components of a dynamic system? Explain.
4. What is natural frequency of a dynamic system?
5. Explain critically damped, over damped and under damped systems.
6. What is damping ratio? What is its significance?
7. Write short notes on 'transient state' and 'steady state' responses.
8. Explain 'dynamic magnification factor'.
9. What is 'impulse response function'? What is its significance?

10. Write short notes on 'Duhamel integral'.
11. Define 'Transmissibility' and explain its use in the design of vibration isolation systems.
12. State and derive the orthogonality properties of mode shape vectors.
14. Explain proportional and non-proportional damping models.
14. Write short notes on 'earthquake response spectrum'.

CO2: Model single and multi degree freedom systems for dynamic analysis and develop equations of motion.

1. Obtain the spring mass model of the system shown and develop the equation of motion. Mass of column may be neglected.

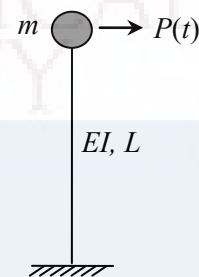

2. A simply supported beam of span L carried a central concentrated mass M . Model the system for analysis of transverse vibrations. Neglect mass of the beam and damping. The flexural rigidity of the beam is EI .

3. Develop spring mass model of the System shown.
Take $m = 30 \text{ kg}$, $EI_1 = 4000 \text{ Nm}^2$,
 $EI_2 = 3200 \text{ Nm}^2$, $l = 1 \text{ m}$ and $k = 2500 \text{ N/m}$.

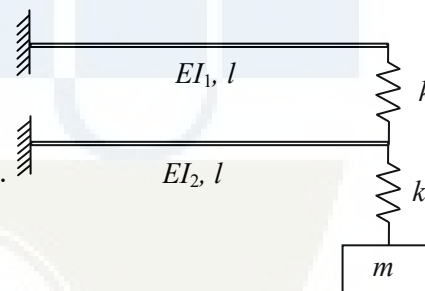

4. A rigid bar of length L is hinged at one end and carries a mass m at the other end. The bar is kept in a horizontal position with the support of a spring of stiffness k placed at a distance a from the hinged end. Formulate the equation of motion. Neglect mass of the bar and damping.

5. Develop spring- mass model of the following frame.

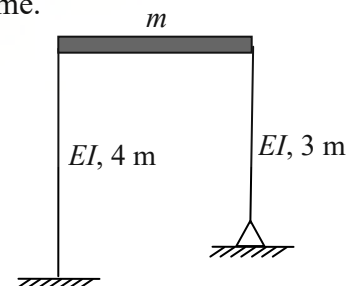

CO3: Estimate parameters of dynamic systems

1. Estimate the stiffness of the system shown in sample Qn. 3 of CO1.
2. A free vibration test is conducted on an empty elevated water tank. A cable attached to the tank applies a horizontal force of 100 kN and pulls the tank horizontally by 40 mm. The cable is suddenly cut and the resulting free vibration is recorded. At the end of four complete cycles, the time is 2 s and the amplitude is 25 mm. From these data compute the following: (a) damped natural frequency, (b) damping ratio, (c) effective stiffness and (d) effective mass
3. Figure shows the time history of displacement response of a SDOF system, of mass 50 kg, undergoing free vibration. Estimate the damped natural frequency, damping ratio and undamped natural frequency of the system. Also determine the stiffness and damping coefficient of the system.

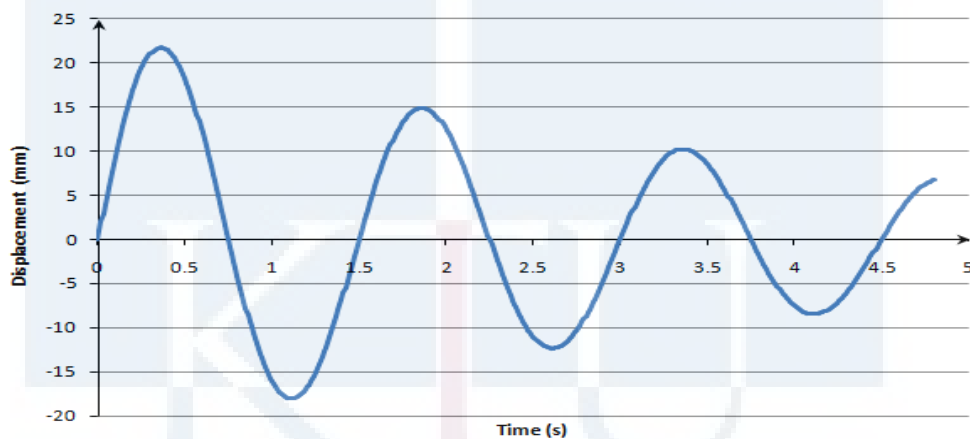

4. A portable harmonic loading machine is used to conduct a test on a single storied building. Harmonic loads of magnitude 2000 N are applied at the floor level at two different frequencies. The data is given below.

Frequency of load (rad/s)	Response Amplitude (cm)	Phase angle (degree)
8	1.50	7
10	2.25	13

Estimate the mass, stiffness and damping of the system assuming it as a single degree of freedom system.

CO4: Perform dynamic analysis of single and multi degree freedom systems.

1. Calculate the natural frequency and natural period of transverse vibrations of a cantilever beam 50 mm diameter circular section carrying a load of 600 N at the free end. Span of the cantilever is 1.0 m. Modulus of elasticity of the material of the beam is 205 GPa. If a spring of stiffness 50 kN/m is introduced between the load

and the beam, calculate the change in the natural frequency and natural period.

2. A SDOF system with mass 20 kg and stiffness 1800 N/m is given an initial displacement of 10 mm and initial velocity of 250 mm/s. Find the displacement of the system at $t = 1.0$ s. Also find the maximum displacement of the system. Neglect damping.
3. A single degree of freedom system with mass 100 kg and stiffness 5000 N/m is subjected to a harmonic load of amplitude 25 N and frequency 6 rad/s. Assuming 10% of critical damping find the steady state amplitude. If the frequency of load is varied, at what frequency the steady state amplitude will reach maximum. Find the maximum value of steady state amplitude also.
4. Find the natural frequencies and mode shapes of the spring-mass system shown in figure. Take $m_1 = 20$ kg, $m_2 = 15$ kg, $k_1 = 1000$ N/m, $k_2 = 1200$ N/m and $k_3 = 900$ N/m.

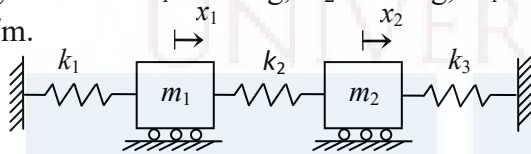

5. Find the natural frequencies and mode shapes of the shear building frame shown. Sketch the mode shapes. Flexural rigidity of the columns = 2×10^6 Nm².
Workout the mass normalized mode shape vectors also.

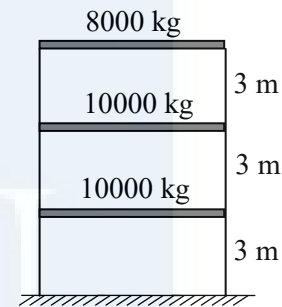

6. Determine the free vibration response of a two storied frame having the following properties: Mass of first floor - 1200 kg, Mass of second floor - 800 kg, Stiffness of first storey columns - 50 kN/m and Stiffness of second storey columns - 30 kN/m. The initial displacements of first and second stories are 5 mm and 12 mm respectively.
7. For a two degrees of freedom lumped mass system,

$$M = \begin{bmatrix} m & 0 \\ 0 & 2m \end{bmatrix}; \quad K = \begin{bmatrix} 2k & -k \\ -k & 3k \end{bmatrix} \quad \text{and the modal matrix } \Phi = \begin{bmatrix} 1 & 1 \\ 1 & -0.5 \end{bmatrix}. \quad \text{The}$$

natural frequencies are given by $\omega_1^2 = \frac{k}{m}$ and $\omega_2^2 = \frac{5}{2} \frac{k}{m}$. The first mass of the system is subjected to a harmonic force $P_0 \cos(\Omega t)$. Determine the response of each of the masses. Neglect damping.

8. For the frame shown in figure the natural frequencies are 15.81 rad/s and 31.62 rad/s. The modal matrix $\Phi = \begin{bmatrix} 1 & 1 \\ 2 & -1 \end{bmatrix}$. Obtain the response of the floors due to a constant ground acceleration of 2 m/s^2 . Also, calculate

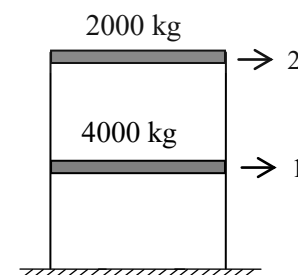

the floor displacements at $t = 1$ s.

CO5: Analyse and design vibration isolation systems.

1. An instrument is attached to a rubber mounting having a static deflection of 3.6 mm. The supporting structure vibrates at a frequency of 30 Hz. If the damping is 3% of critical, estimate the % reduction in the transmitted support motion.
2. A delicate instrument of weight 200 kg is to be mounted on a factory floor using a vibration isolation suspension. The floor is vibrating with an amplitude of 0.25 mm and frequency 15 Hz. The maximum displacement that can be tolerated by the instrument for reliable operation is 0.1 mm. Find the stiffness of the suspension springs assuming 5% of critical damping.
3. A vibration isolation block (as shown in figure) is to be installed in a laboratory so that the vibration from adjacent factory operations will not disturb certain experiments. If the isolation block weighs 900 kg and the surrounding floor and foundation vibrates at 1500 cycles/minute, determine the stiffness of the isolation system such that the motion of the isolation block is limited to 20% of floor vibration. Assume damping as 10%.

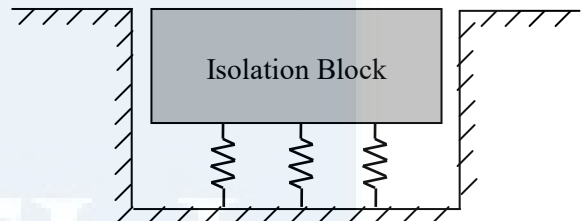

CO6: Develop equations of motion for dynamic analysis of beams and perform free vibration analysis of simply supported beam.

1. Derive the differential equation governing the flexural vibration of beams.
2. Find the first three natural frequencies and mode shapes of a simply supported beam of span L having uniform flexural rigidity EI and mass \bar{m} per unit length. Sketch the mode shapes also.
3. A steel rod of 20 mm diameter having length 2.0 m is simply supported at its ends. Find its fundamental frequency of flexural vibration. Take density of steel as 7850 kg/m^3 . Modulus of elasticity of steel may be taken as 200 GPa.

Module I

Introduction – Parameters of dynamic system – D'Alembert's principle, Equation of motion of SDOF systems – undamped free vibration analysis. Damped free vibration analysis. Measurement of damping – Logarithmic decrement, Response to harmonic loading - steady state and transient states – steady state amplitude, Dynamic magnification factor.

Module II

Response of SDOF systems to rectangular load, triangular load and half sine pulse. Impulse response function, Response to general loads-Duhamel's integral. Response of SDOF system to support motion, Vibration Isolation, transmissibility

Module III

Multi degree of freedom systems – Lumped mass systems, shear building frame, Equation of motion, free vibration analysis, Natural frequencies and mode shapes, orthogonality of normal modes.

Module IV

Forced vibration analysis of multi degree of freedom systems – mode superposition method. Response of MDOF systems subjected to harmonic load. MDOF system subjected to support motion.

Module V

Introduction to earthquake analysis - Response spectrum. Response spectrum analysis of MDOF systems. Distributed parameter systems, Differential equation – beam flexure (elementary case), undamped free vibration analysis of simply supported beams.

Text Books:

- 1) Mario Paz, *Structural Dynamics*, CBS Publishers, New Delhi, India, 2001.
- 2) Mukhopadhyay M., *Vibrations, Dynamics and Structural Systems*, Taylor & Francis, London, 2000.

References:

- 1) Clough R. W. and J. Penzien, *Dynamics of Structures*, McGraw Hill, 1993.
- 2) Chopra A. K., *Dynamics of Structures- Theory and application to Earthquake Engineering*, Pearson Education India, 2007.
- 3) Biggs J. M., *Introduction to Structural Dynamics*, McGraw-Hill Book Inc., New York, 1964.
- 4) J.W. Smith, *Vibration of Structures*, Chapman and Hall, London.

Module	Topic	Course Outcomes addressed	No. of Lectures
1	Module I : Total lecture hours : 10		
1.1	Introduction to structural dynamics and its importance in Civil Engineering. Dynamic Load, Parameters of dynamic system	CO1	1
1.2	D'Alembert's principle, Equation of motion of SDOF system. Undamped free vibration analysis, concept of natural frequency	CO1, CO2	1
1.3	Modeling systems as SDOF spring-mass model, estimation of stiffness, determination of natural frequency	CO2, CO3	2
1.4	Free vibration response of undamped SDOF systems	CO4	1
1.5	Damped free vibration analysis – concept of critical damping and damping ratio, underdamped and overdamped systems	CO1, CO4	1
1.6	Free vibration response of damped SDOF systems – measurement of damping – logarithmic decrement.	CO1, CO3, CO4	1
1.7	Response of damped SDOF systems to harmonic loading – transient state and steady state responses. Response of undamped SDOF systems to harmonic loading.	CO1, CO4	2
1.8	Steady state amplitude, Dynamic magnification factor, concept of resonance, frequency response plot of SDOF systems.	CO1, CO4	1
2	Module II : Total lecture hours : 10		
2.1	Response of undamped and damped SDOF systems to rectangular load.	CO4	1
2.2	Response of undamped and damped SDOF systems to triangular load.	CO4	2
2.3	Response of undamped and damped SDOF systems to half sine pulse.	CO4	1
2.4	Impulse response function for undamped and damped systems Response to general load – concept of Duhamel's integral.	CO1, CO4	1
2.5	Response of undamped and damped SDOF systems to support motion.	CO4	2
2.6	Vibration isolation – force and displacement isolation, Transmissibility ratio.	CO1, CO5	2

2.7	Design of vibration isolation systems	CO5	1
3	Module III : Total lecture hours : 10		
3.1	Multi-degree of freedom (MDOF) systems- examples, Lumped mass systems, Shear building frames	CO1, CO4	1
3.2	Modelling of MDOF systems, Equation of motion	CO2, CO3	2
3.3	Undamped free vibration analysis, Natural frequencies and mode shapes, orthogonality of mode shapes	CO1, CO4	3
3.4	Mode superposition method - Free vibration response of undamped MDOF systems	CO1, CO4	2
3.5	Mode superposition method -Free vibration response of damped MDOF systems, concept of modal damping.	CO1, CO4	2
4	Module IV : Total lecture hours : 8		
4.1	Forced vibration analysis - Mode superposition method.	CO1, CO4	1
4.2	Response of MDOF systems subjected to harmonic load. Maximum modal responses and modal combination using SRSS rule.	CO1, CO4	3
4.3	MDOF system subjected to support motion – Equation of motion.	CO2	1
4.4	Response of shear building frames subjected to support acceleration - maximum floor response using SRSS rule.	CO2, CO4	2
4.5	Concept of frequency response function (FRF) of MDOF systems.	CO1	1
5	Module V : Total lecture hours : 7		
5.1	Introduction to earthquake analysis, Response spectrum – concept, Development of response spectrum	CO1	1
5.2	Response spectrum analysis of MDOF systems.	CO4	2
5.3	Distributed parameter systems, Differential equation for beam flexure (elementary case) and its solution	CO1, CO6	2
5.4	Undamped free vibration analysis of simply supported beam – natural frequencies and mode shapes	CO6	1
5.5	Undamped free vibration analysis of beams with different boundary conditions (formulation only)	CO6	1

Reg.No.: _____

Name: _____

APJ ABDUL KALAM TECHNOLOGICAL UNIVERSITY
FIFTH SEMESTER B.TECH DEGREE EXAMINATION

Course Code: CET393

Course Name: STRUCTURAL DYNAMICS

Max. Marks: 100

Duration: 3 Hours

PART A

Answer all questions; each question carries 3 marks.

1.
 - a) Explain critically damped, over damped and under damped systems.
 - b) Distinguish between 'transient state' and 'steady state' responses.
 - c) What is 'impulse response function'? What is its significance?
 - d) Define 'Transmissibility' and explain its use in the design of vibration isolation systems.
 - e) What do you mean by shear building frames?
 - f) Explain orthogonality of mode shapes.
 - g) Explain mode superposition method of analysis.
 - h) Derive the equation of motion of a two storied shear building frame subjected to support motion.
 - i) What is earthquake response spectrum?
 - j) Derive the partial differential equation governing the flexural vibration of beams. Neglect damping and effect of axial force.

(10×3 marks = 30 marks)

PART B

Answer one full question from each module; each full question carries 14 marks.

Module I

2. A free vibration test is conducted on an empty elevated water tank. A cable attached to the tank applies a horizontal force of 100 kN and pulls the tank horizontally by 40 mm. The cable is suddenly cut and the resulting free vibration is recorded. At the end of four complete cycles, the time is 2 s and the amplitude is 25 mm. From these data compute the following: (a) damped natural frequency, (b) damping ratio, (c) effective stiffness, (d) effective mass and (e) amplitude of displacement after 10 cycles.
3. A portable harmonic loading machine is used to conduct a test on a single storied building. Harmonic loads of magnitude 2000 N are applied at the floor level at two different frequencies. The data is given below.

Frequency of load(rad/s)	Response Amplitude(cm)	Phase angle(degree)
--------------------------	------------------------	---------------------

8	1.50	CIVIL ENGINEERING 7
10	2.25	13

Estimate the mass, stiffness and damping of the system assuming it as a single degree of freedom system

Module II

4. A single degree of freedom system with $m = 10$ kg and $k = 1.2$ kN/m is subjected to a half sine load as shown in figure. Find expressions for the displacement of the system for $t < 0.4$ s and $t > 0.4$ s. Neglect damping. Assume that the system starts from rest.

What is the displacement at $t = 0.4$ s ?

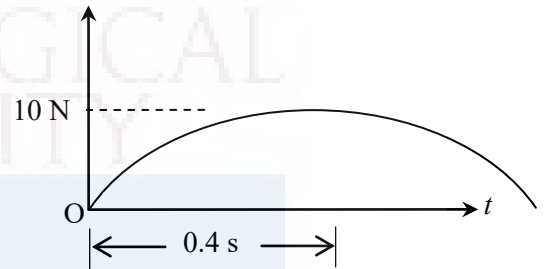

5. A sieving machine weighs 2500 kg and when operating at full capacity, it exerts a harmonic force of 3 kN amplitude at 20 Hz on its supports. After mounting the machine on spring-type vibration isolators, it was found that the amplitude of the harmonic force exerted on the supports had been reduced to 250 N. Determine the stiffness of the isolator springs. Assume damping as 10% of critical.

Module III

6. Find the natural frequencies and mode shapes of the spring-mass system shown in figure. Take $m_1 = 20$ kg, $m_2 = 15$ kg, $k_1 = 1000$ N/m, $k_2 = 1200$ N/m and $k_3 = 900$ N/m.

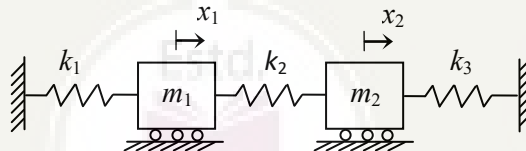

7. Determine the free vibration response of a two storied frame having the following properties: Mass of first floor - 1200 kg, Mass of second floor - 800 kg, Stiffness of first storey columns - 50 kN/m and Stiffness of second storey columns - 30 kN/m. The initial displacements of first and second stories are 5 mm and 12 mm respectively.

Module IV

8. For a two degrees of freedom lumped mass system,

$$M = \begin{bmatrix} m & 0 \\ 0 & 2m \end{bmatrix}; \quad K = \begin{bmatrix} 2k & -k \\ -k & 3k \end{bmatrix} \quad \text{and the modal matrix } \Phi = \begin{bmatrix} 1 & 1 \\ 1 & -0.5 \end{bmatrix}. \quad \text{The natural}$$

frequencies are given by $\omega_1^2 = \frac{k}{m}$ and $\omega_2^2 = \frac{5}{2} \frac{k}{m}$. The first mass of the system is subjected

to a harmonic force $P_0 \cos(\Omega t)$. Determine the response of each of the masses. Neglect damping.

9. For the frame shown in figure the natural frequencies are 15.81 rad/s and 31.62 rad/s. The modal matrix

$$\Phi = \begin{bmatrix} 1 & 1 \\ 2 & -1 \end{bmatrix}$$

Obtain the response of the floors due to a constant ground acceleration of 2 m/s^2 . Also, calculate the floor displacements at $t = 1 \text{ s}$.

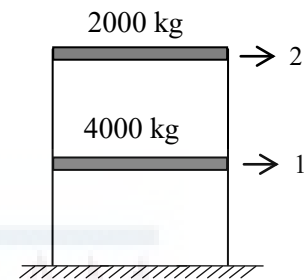

Module V

10. Explain response spectrum analysis of MDOF shear building frames subjected to earthquake ground acceleration. Derive the relevant equations.
11. Find the first three natural frequencies and mode shapes of a simply supported beam of span L having uniform flexural rigidity EI and mass \bar{m} per unit length. Sketch the mode shapes also.

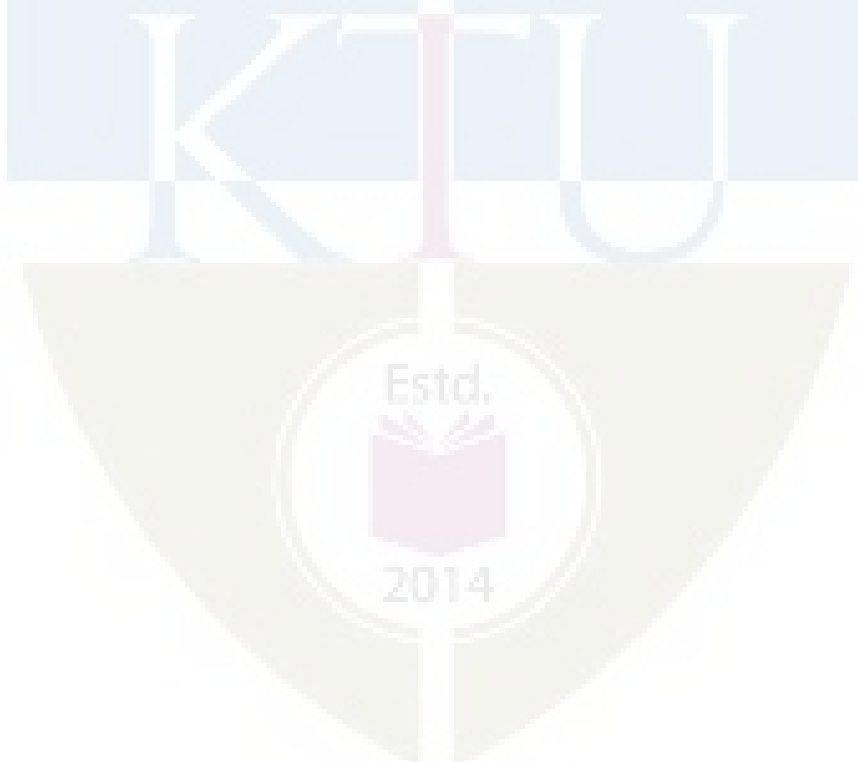

CET395	TRANSPORTATION SYSTEMS MANAGEMENT	CATEGORY	L	T	P	CREDIT	Year of Introduction
		VAC	3	1	0	4	2019

Preamble: Objective of the course is to impart an awareness on transportation system management, TSM strategies, promotion of non-transport modes and advanced transit technologies.

Prerequisite: Nil

Course Outcomes: After the completion of the course, the student will be able to:

CO 1	Apply a transportation system management strategy based on TSM goal or objective.
CO 2	Recommend methods to manage a transit system to improve its management efficiency.
CO 3	Recommend measures for the promotion of non-transport modes for a transportation system based on a goal or objective.
CO 4	Assess the suitability of advanced transit technologies in a transportation system.

Mapping of course outcomes with program outcomes

	PO 1	PO 2	PO 3	PO 4	PO 5	PO 6	PO 7	PO 8	PO 9	PO 10	PO 11	PO 12
CO 1	3	1				2		1			1	2
CO 2	2	1				2		1			1	2
CO 3	1					2	3	1			1	2
CO 4	1				1	2	1	1	1		1	2

Assessment Pattern

Bloom's Category	Continuous Assessment		End Semester Examination (marks)
	Test 1 Marks	Test 2 Marks	
Remember	10	10	40
Understand	10	10	40
Apply	5	5	20
Analyse			
Evaluate			
Create			

Mark Distribution

Total Marks	CIE (Marks)	ESE (Marks)	ESE Duration
150	50	100	3 hours

Continuous Internal Evaluation Pattern:

Attendance	: 10 marks
Continuous Assessment Test (2 numbers)	: 25 marks
Assignment/Quiz/Course Project	: 15 marks

End Semester Examination Pattern:

The question consists of two parts- Part A and Part B. Part A consists of 10 questions with 3 marks for each (two questions from each module). Part B consists of two questions from each module, out of which one has to be answered. Each question carries 14 marks and can have maximum 2 subdivisions.

Sample Course Level Assessment Questions:

Course Outcome 1 (CO1): Recommend and discuss two methods for reducing peak period traffic?

Course Outcome 2 (CO2): Identify the issues of multi-modal coordination?

Course Outcome 3 (CO3): As per IRC code, describe the features adopted for bicycle tracks to popularise bicycle traffic in an Indian urban area.

Course Outcome 4 (CO4): Discuss on whether Indian population would adapt to the various advanced transit measures popular in many developed nations.

Syllabus**Module 1**

System approach to Transportation Planning; The need for TSM, Long range versus TSM Planning TSM characteristics: TSM planning cycle, TSM strategies, Objectives and Philosophy; Relevance of TSM actions in Indian context. Measures for Improving vehicular flow – one-way Streets, Signal Improvement, Transit Stop Relocation, Parking Management, Reversible lanes- Reducing Peak Period Traffic – Strategies for working hours, Congestion Pricing; Traffic calming measures

Module 2

Public Transport: Preferential Treatment to high Occupancy Vehicles; Transit system operations, Service and characteristics, Transit Service Improvement Measures; Car Pooling; Transit Management Improvement Measure; Multi-Modal Coordination; Transit and Para transit integration;

Module 3

Bus Route Network Planning and Management: Type of Bus Route Networks; Suitability for a given Urban Area; Types of routes – Corridor routes, activity routes and residential routes; Issues in route networks evaluation – number of route, length of route; Route alignment methods; service coverage and accessibility index.

Module 4

Local area traffic management: Promotion of Non – motorised modes: Measures to promote; Pedestrianisation: Pedestrian facilities and management. Bicycle Transportation – advantages; Planning Bicycle Facilities Junction Treats for cycle tracks;LOS criteria for Pedestrian and bicycle Facilities.

Module 5

Advanced Transit Technologies: Conventional and Unconventional Systems; Rapid Transportation System; New technologies – LRT, monorail, Automated Highways- Hovercraft; System Characteristics and Suitability.

Text Books :

1. C. J. Khisty and B. K. Lall, Transportation Engineering: An Introduction, Prentice- Hall India, 2003.
2. Transportation Demand Management (TDM) Encyclopedia, Victoria Transport Policy Institute Canada, 2006.

References:

1. Transportation Engineering and Planning, by C. S. Papacostas and P. D. Prevedouros, PrenticeHall of India Private Limited 2001
2. Roger P. Roess, William R. McShane & Elena S. Prassas, Traffic Engineering, Prentice-Hall, 1990.

Course Content and lecture Schedule:

No.	Topic	Course Outcome	No. of Hrs
1	Module 1		Total: 9
1.1	System approach to Transportation Planning; The need for TSM, Long range verses TSM Planning	CO1	1
1.2	TSM characteristics: TSM planning cycle, TSM strategies, Objectives and Philosophy; Relevance of TSM actions in Indian context.	CO1	1
1.3	Measures for Improving vehicular flow – one-way Streets, Signal Improvement, Transit Stop Relocation, Parking Management, Reversible lanes- Reducing Peak Period Traffic –	CO1	7

	Strategies for working hours, Congestion Pricing.		
2	Module 2		Total: 9
2.1	Public Transport: Preferential Treatment to high Occupancy Vehicles; Transit system operations, Service and characteristics, Transit Service Improvement Measures; Car Pooling;	CO2	4
2.2	Transit Management Improvement Measure; Multi-Modal Coordination; Transit and Para transit integration;	CO2	5
3	Module 3		Total: 9
3.1	Bus Route Network Planning and Management: Type of Bus Route Networks; Suitability for a given Urban Area;	CO2	2
3.2	Types of routes – Corridor routes, activity routes and residential routes;	CO2	2
3.3	Issues in route networks evaluation – number of route, length of route;	CO2	2
3.4	Route alignment methods; service coverage and accessibility index.	CO2	3
4	Module 4		Total: 9
4.1	Local area traffic management: Promotion of Non – motorised modes: Measures to promote;	CO3	1
4.2	Pedestrianisation: Pedestrian facilities and management. IRC codes.	CO3	2
4.3	Bicycle Transportation – advantages; Planning Bicycle Facilities Junction Treats for cycle tracks; IRC codes for bicycle facilities.	CO3	4
4.4	LOS criteria for Pedestrian and bicycle Facilities.	CO3	2
5	Module 5		Total: 9
5.1	Advanced Transit Technologies: low carbon vehicles; Automated Highways: System Characteristics and Suitability, Electric vehicles, Automated vehicles: Planning, infrastructure and implementation; issues.	CO4	4
5.2	Rapid Transportation System; New technologies – LRT, monorail, Bus rapid transit system (BRTS), Rail rapid transit system(RRTS).	CO4	5

Model Question Paper

**APJ ABDUL KALAM TECHNOLOGICAL UNIVERSITY
FIFTH SEMESTER B. TECH DEGREE EXAMINATION, MONTH & YEAR**

Course Code: **CET395**

Course Name: **TRANSPORTATION SYSTEMS MANAGEMENT**

Marks:100

Duration: 3 hrs

PART A

(Answer all Questions: Each question carries 3 marks)

- 1 Mention the need for Transportation System Management.
- 2 Discuss about the relevance of TSM actions in Indian context?
- 3 What are the issues related to transit and para transit integration?
- 4 Discuss about carpooling.
- 5 What are the strategies adopted for fixing suitable bus network for a given Urban Area?
- 6 Comment on how to arrive at an accessibility index for a transit route.
- 7 Suggest the measures to be taken to promote NMT in Indian cities.
- 8 What considerations are to be made for planning proper bicycle Facilities for an urban area?
- 9 Mention some important features suggested for automated highways.
- 10 Why should planners recommend BRTS for urban areas?

(3 x 10=30 marks)

PART B

(Answer one full question from each module)

- | | | |
|-----------|--|---|
| 11 a. | Describe the system approach to transportation planning | 7 |
| b. | What are reversible lanes? How does it help to improve traffic flow? | 7 |
| OR | | |
| 12 a. | Mention the objectives of TSM? | 7 |
| b. | How is congestion pricing carried out to improve traffic flow? | 7 |
| 13 a. | What are the service characteristics of transit operations? | 7 |
| b. | List out the five pillars of multi-modal integration? Explain each. | 7 |

OR

- | | | |
|----|--|----|
| 14 | List out the preferential treatments to High Occupancy Vehicles. Explain any | 14 |
|----|--|----|

five in detail.

15 Compare and contrast the different route adopted under network planning strategies. 14

OR

16 a. How do you evaluate the effectiveness of bus route network? 7

b. Describe in detail any method adopted by planners to align route in the urban road networks. 7

17 a. List down the characteristics of Non – motorised modes of traffic. 7

b. How can the LOS criteria for Pedestrian formulated? 7

OR

18 a. Suggest the modifications to be adopted in an urban roadway to enhance the pedestrian facilities in reference to the IRC codes. 7

b. Discuss the Junction Treatments to be facilitated for laying cycle tracks. 7

19 a. What are the infrastructural facilities required for a properly planned electric transit vehicle system in a typical Indian city 7

b. Compare and contrast any two popular Rapid Transportation Systems. 7

OR

20 a. What are the infrastructural and service characteristics advised for a typical Indian city to be employed with an automatic highway? 7

b. What are the measures that can be adopted for enhancing the usage of rail as a transit mode? 7



CET397	GROUND WATER HYDROLOGY	Category	L	T	P	Credit	Year of Introduction
		VAC	3	1	0	4	2019

Preamble: The general objective of this course is to expose the students to the fundamental concepts of groundwater hydrology and its engineering applications. The course aim to impart the knowledge on the hydraulics of subsurface fluid flow, characteristics of porous media, well flow near aquifer boundaries, surface investigation of ground water, quality of ground water, artificial recharge and ground water flow modeling.

Pre-requisite: NIL

Course outcome

After the course, the student will be able to:

CO1	Understand the occurrence and movement of ground water through porous media and apply Darcy’s law to simple ground water flow problems
CO2	Determine the aquifer parameters using different methods
CO3	Estimate drawdown in wells due to the effect of aquifer boundaries and thickness of aquifers
CO4	Estimate sea water intrusion length and fresh water discharge into the sea
CO5	Perform numerical modeling of ground water system

CO-PO Mapping

CET397 Ground Water Hydrology		PO1	PO2	PO3	PO4	PO5	PO6	PO7	PO8	PO9	PO10	PO11	PO12
	CO1	3	3					1					
	CO2	3	3					1					
	CO3	3	2					1					
	CO4	3	3					1					
	CO5	3	3					1					

Assessment pattern

Bloom's Category	Continuous Assessment Tests		End Semester Examination (Marks)
	Test 1 (Marks)	Test 2 (Marks)	
Remember	5	5	15
Understand	10	10	15
Apply	20	20	40
Analyze	15	15	30
Evaluate			
Create			

Continuous Internal Evaluation Pattern:

Attendance	:	10 marks
Continuous Assessment Test (2 numbers)	:	25 marks
Assignment/Quiz/Course project	:	15 marks
Total	:	50 marks

End semester examination pattern – There will be two parts; Part A and Part B. Part A contain 10 questions with 2 questions from each module, having 3 marks for each question. Students should answer all questions. Part B contains 2 questions from each module of which student should answer any one. Each question can have maximum 2 sub-divisions and carry 14 marks.

Course Code: CET 397
Ground Water Hydrology
(Course plan)

Module	Topic	Course outcome addressed	No of Hours
Module I (10 Hours)			
1.1	Vertical distribution of ground water-Types of geologic formations	CO1	1
1.2	Properties of aquifer related to storage and transmissivity of water	CO1	1
1.3	Darcy's law, Steady unidirectional flow	CO1	1
1.4	Steady flow in a homogenous aquifer	CO1	1

1.5	Problems from unidirectional flow	CO1	2
1.6	Aquifer with recharge	CO1	1
1.7	Flow into infiltration galleries	CO1	1
1.8	Problems	CO1	2
Module II (8 Hours)			
2.1	Partial differential equation governing unsteady ground water flow	CO2	1
2.2	Unsteady radial flow towards well	CO2	1
2.3	Evaluation of aquifer parameters- Theis method	CO2	1
2.4	Evaluation of aquifer parameters- Jacob's method	CO2	1
2.5	Evaluation of aquifer parameters- Chow's method	CO2	1
2.6	Problems- Evaluation of aquifer parameters	CO2	3
Module III (11 Hours)			
3.1	Well flow near aquifer boundaries	CO3	1
3.2	Image well system	CO3	1
3.3	Method of images –particular cases	CO3	1
3.4	Problems from method of images	CO3	2
3.5	Surface investigation of ground water	CO3	1
3.6	Electrical resistivity method	CO3	1
3.7	Seismic refraction method	CO3	1
3.8	Determination of aquifer thickness of horizontal aquifers	CO3	1
3.9	Problems- resistivity method, seismic refraction	CO3	2
Module IV (9 Hours)			
4.1	Quality of ground water –Graphical representations	CO4	1
4.2	Pollution of ground water-sources	CO4	1
4.3	Distribution and evaluation of ground water pollution	CO4	1
4.4	Sea water intrusion-Ghyben-Herzberg equation	CO4	1
4.5	Sea water-fresh water interface	CO4	1
4.6	Length of intrusion	CO4	1
4.7	Upconing , Sea water intrusion- preventive measures	CO4	1
4.8	Problems- Sea water intrusion	CO4	2
Module V (7 Hours)			
5.1	Artificial recharge of ground water- different techniques	CO5	1
5.2	Modelling of ground water flow	CO5	1
5.3	Governing equations of ground water flow and boundary conditions	CO5	1
5.4	Solution of partial differential equation of ground water flow for 1D steady ground water flow in homogenous aquifer using finite difference method	CO5	4

CET 397: Ground Water Hydrology Syllabus

Module I

Vertical distribution of groundwater- Types of geologic formations, Properties of aquifer related to storage and transmissivity of water, Darcy's law, Steady unidirectional flow- steady flow in a homogenous aquifer- aquifer with recharge- flow into infiltration galleries. (Problems from unidirectional flow)

Module II

Partial differential equation governing unsteady groundwater flow- unsteady radial flow towards well. Evaluation of aquifer parameters by Theis, Jacob's and Chow's method. (Problems from evaluation of aquifer parameters)

Module III

Well flow near aquifer boundaries- Image well system. Method of images- Practical cases (Problems from method of images). Surface investigation of ground water- different methods- electrical resistivity method, seismic refraction method- determination of aquifer thickness of horizontal aquifers (Problems from resistivity method, seismic refraction)

Module IV

Quality of ground water- Graphical representations. Pollution of ground water- sources, distribution and evaluation of ground water pollution (Brief description only). Sea water intrusion- Ghyben-Herzberg equation, sea water-fresh water interface, length of intrusion, upconing, preventive measures.(Problems from sea water intrusion)

Module V

Artificial recharge of ground water-different techniques. Modelling of ground water flow- governing equations of ground water flow and boundary conditions (basic ideas only), solution of partial differential equation of ground water flow for 1D steady ground water flow in homogenous aquifers (confined and unconfined) using finite difference method (uniform mesh interval only)

Text Books:

1. D.K. Todd, "Ground Water Hydrology", Wiley International Ed; Toppan & Company Ltd, Tokyo, 1995.
2. H.M. Raghunath, "Groundwater", New Age International Publishers, New Delhi, 2007.
3. A.K. Rastogi, "Numerical Ground Water Hydrology", Penram International Publishers, Mumbai

References:

1. Karanth, "Ground Water Assessment, Development and Management" Tata McGraw Hill publishing company Ltd.
2. "Ground Water Manual", A Water Resources Technical Publication.
3. S.P Garg, "Ground Water and tube wells", Oxford & IBH Publishing Company.
4. Punmia B.C. Ashok K Jain, Arun K Jain, B. B. L Pande, "Irrigation and Water Power Engineering", Laxmi Publications (P) Ltd. 2009
5. Herman Bouwer, "Ground Water Hydrology", MC Graw Hill Kogakusha Ltd.
6. H.M. Raghunath, "Ground Water Hydrology", Wiley Eastern Limited.
7. Neven Kresic, "Hydrogeology and Ground Water modeling", CRC press, Taylor & Francis group, 2007.
8. Freeze and Cherry, "Ground Water", Prentice Hall



Course Code: CET 397
Ground Water Hydrology
(Course Level Assessment Questions)

Qn No	Question	Marks	Course outcome (CO) Assessed
Part A (Answer ALL Questions)			
1	Explain different properties of aquifer	3	CO1
2	What is an infiltration gallery? Explain with figure.	3	CO1
3	Briefly explain Theis method of estimation of aquifer parameters	3	CO2
4	What are the assumptions in the derivation of partial differential equation of unsteady radial flow towards wells?	3	CO2
5	Find the number of image wells and locate the image wells when the aquifer is delimited by two converging recharge boundaries at right angles.	3	CO3
6	What are the applications of electrical resistivity method?	3	CO3
7	What are the different sources of pollution of ground water? Explain briefly	3	CO4
8	Explain upconing with neat sketch	3	CO4
9	Write the equations for the second order head gradient of an aquifer using central, forward and backward difference schemes	3	CO5
10	Write the governing equations of groundwater flow and boundary conditions	3	CO5
Part B (Answer ANY ONE FULL question from each module)			
Module I			
11(a)	Explain different types of aquifer with neat sketches	7	CO1
11(b)	In a field test, time of 6 hour was required for a tracer to	7	CO1

	travel between two observation wells 42 m apart. If the difference in water-table elevations in these wells were 0.85 m and the porosity of the aquifer is 20%, calculate the coefficient of permeability of the aquifer.																				
12(a)	State Darcy's law and its limitations	4	CO1																		
12(b)	Sketch a typical infiltration gallery. Derive the equation for discharge per unit length of the infiltration gallery and phreatic surface by making suitable assumptions.	10	CO1																		
Module II																					
13(a)	Derive partial differential equation for unsteady ground water flow	10	CO2																		
13(b)	A well of 30 cm diameter is located in a confined aquifer of transmissibility $500\text{m}^2/\text{day}$ and storage coefficient of 0.005. What pumping rate will have to be adopted if the drawdown at the well is not to exceed 10 m in 2 days.	4	CO2																		
14(a)	The time drawdown data recorded at an observation well situated at a distance of 50 m from the pumping well is given below.	9	CO2																		
	<table border="1" style="width: 100%; border-collapse: collapse;"> <thead> <tr> <th style="text-align: left;">Time (min)</th> <th style="text-align: left;">Drawdown (m)</th> </tr> </thead> <tbody> <tr><td>1.5</td><td>0.15</td></tr> <tr><td>3</td><td>0.6</td></tr> <tr><td>4.4</td><td>1</td></tr> <tr><td>6</td><td>1.4</td></tr> <tr><td>10</td><td>2.4</td></tr> <tr><td>20</td><td>3.7</td></tr> <tr><td>40</td><td>5.1</td></tr> <tr><td>100</td><td>6.9</td></tr> </tbody> </table>			Time (min)	Drawdown (m)	1.5	0.15	3	0.6	4.4	1	6	1.4	10	2.4	20	3.7	40	5.1	100	6.9
	Time (min)			Drawdown (m)																	
	1.5			0.15																	
	3			0.6																	
	4.4			1																	
	6			1.4																	
	10			2.4																	
	20			3.7																	
	40			5.1																	
100	6.9																				
If the well discharge is $1.8\text{ m}^3/\text{min}$, calculate the transmissibility and storage coefficient of the aquifer using modified Theis method.																					
14(b)	Describe the method for the estimation of aquifer parameters by Chow's method.	5	CO2																		
Module III																					
15 (a)	Describe the seismic refraction method for groundwater investigation with a neat sketch.	7	CO3																		
15(b)	An aquifer is delineated by two converging barrier boundaries, the angle of wedge being 45° . Compute the number of image wells associated with the wedge shaped	7	CO3																		

	boundary system and mark them neatly in a sketch.		
16 (a)	In a seismic refraction survey for locating an aquifer, slopes of 1.66×10^{-3} and 0.000625 s/m were noted from the time-distance plots. If the cross-over distance is 20.76 m, compute the depth to the aquifer, the critical shot-geophone distance, and the correct angle of incidence for the refraction along the interface.	5	CO3
16 (b)	A 30cm well is pumped at the rate of 1000 lpm. The transmissibility of the aquifer is $0.015\text{m}^2/\text{s}$. If the well is located at a distance of 120m from a stream, what should be the drawdown (i) In the pumping well (ii) In an observation well 100m away from the pumping well on the side opposite to the stream (iii) In an observation well 85m away from the pumping well, on a line parallel to the stream.	9	CO3
Module IV			
17(a)	Derive the relationship between length of interface and freshwater discharge in a confined aquifer.	8	CO4
17(b)	Explain different water quality plots with neat sketches	6	CO4
18(a)	Describe the preventive measures to control saltwater intrusion into coastal aquifers with neat sketches.	7	CO4
18(b)	By conductivity measurements in a well in a coastal aquifer extending 4 km along the shore, the interface was located at a depth of 20 m below m.s.l. at 100 m from the shore, inland. The depth of the homogenous aquifer is 30 m below m.s.l. and has a permeability of 50 m/day. What is the rate of fresh water flow into the sea and the width of gap at the shore bottom through which it escapes into the sea? What is the position of the toe of the saltwater wedge? Use Glover's method.	7	CO4
Module V			
19 (a)	Explain different techniques of artificial recharge of ground water with neat sketches.	8	CO5
19 (b)	Find the numerical value of the third and fourth order aquifer head gradient by the forward, backward and	6	CO5

	central difference method assuming uniform head distribution in a confined aquifer between two wells located 4 Km apart with piezometric levels of 100 m and 102 m respectively. Take these two wells as the extreme nodes.		
20 (a)	One dimensional steady state flow is happening in a confined aquifer with transmissivity T. The aquifer is bounded by an impervious boundary to the left and a constant head boundary to the right. Ground water flows into the aquifer due to a constant recharge Q through an aquitard. Assuming $Q=0.0005\text{m/day}$, $T=500\text{ m/day}$, thickness of aquifer $b=100\text{m}$, length of aquifer $L=5\text{ Km}$, Constant head of right boundary $H=100\text{ m}$, find the head at different nodes using central difference scheme.(Take discretization interval as 1250 m)	10	CO5
20 (b)	Write any six applications of ground water models.	4	CO5



Model Question Paper**Pages: 3**

Reg No.:.....

QP

CODE:.....

Name:.....

**APJ ABDUL KALAM TECHNOLOGICAL UNIVERSITY
FIFTH SEMESTER B.TECH DEGREE EXAMINATION, MONTH & YEAR****Course Code: CET 397****Ground Water Hydrology****Max. Marks: 100
hours****Duration: 3****Part A****(Answer all questions; each question carries 3 marks)**

1. Explain different properties of aquifer
2. What is an infiltration gallery? Explain with figure.
3. Briefly explain Theis method of estimation of aquifer parameters
4. What are the assumptions in the derivation of partial differential equation of unsteady radial flow towards wells?
5. Find the number of image wells and locate the image wells when the aquifer is delimited by two converging recharge boundaries at right angles.
6. What are the applications of electrical resistivity method?
7. What are the different sources of pollution of ground water? Explain briefly
8. Explain upconing with neat sketch
9. Write the equations for the second order head gradient of an aquifer using central, forward and backward difference schemes
10. Write the governing equations of groundwater flow and boundary conditions

Part B**(Answer one full question from each module, each question carries 14 marks)****Module I**

- 11 (a) Explain different types of aquifer with neat sketches (7 Marks)
- (b) In a field test, time of 6 hour was required for a tracer to travel between two observation wells 42 m apart. If the difference in water-table elevations in these wells were 0.85 m and the porosity of the aquifer is 20%, calculate the coefficient of permeability of the aquifer. (7 Marks)

OR

- 12.(a) State Darcy's law and its limitations (4 Marks)
- (b) Sketch a typical infiltration gallery. Derive the equation for discharge per unit length of the infiltration gallery and phreatic surface by making suitable assumptions. (10 Marks)

Module II

- 13(a) Derive partial differential equation for unsteady ground water flow (10 Marks)
- (b) A well of 30 cm diameter is located in a confined aquifer of transmissibility $500\text{m}^2/\text{day}$ and storage coefficient of 0.005. What pumping rate will have to be adopted if the drawdown at the well is not to exceed 10 m in 2 days. (4 Marks)

OR

- 14.(a) The time drawdown data recorded at an observation well situated at a distance of 50 m from the pumping well is given below.

Time (min)	Drawdown (m)
1.5	0.15
3	0.6
4.4	1
6	1.4
10	2.4
20	3.7
40	5.1
100	6.9

If the well discharge is $1.8\text{ m}^3/\text{min}$, calculate the transmissibility and storage coefficient of the aquifer using modified Theis method. (9 Marks)

(b) Describe the method for the estimation of aquifer parameters by Chow's method.

(5 Marks)

Module III

15. (a) Describe the seismic refraction method for groundwater investigation with a neat sketch. (7 Marks)

(b) An aquifer is delineated by two converging barrier boundaries, the angle of wedge being 45° . Compute the number of image wells associated with the wedge shaped boundary system and mark them neatly in a sketch. (7 Marks)

OR

16. (a) In a seismic refraction survey for locating an aquifer, slopes of 1.66×10^{-3} and 0.000625 s/m were noted from the time-distance plots. If the cross-over distance is 20.76 m, compute the depth to the aquifer, the critical shot-geophone distance, and the correct angle of incidence for the refraction along the interface.

(5 Marks)

(b) A 30cm well is pumped at the rate of 1000 lpm. The transmissibility of the aquifer is $0.015 \text{ m}^2/\text{s}$. If the well is located at a distance of 120m from a stream, what should be the drawdown

(i) In the pumping well

(ii) In an observation well 100m away from the pumping well on the side opposite to the stream

(iii) In an observation well 85m away from the pumping well, on a line parallel to the stream. (9 Marks)

Module IV

17 (a) Derive the relationship between length of interface and freshwater discharge in a confined aquifer. (8 Marks)

(b) Explain different water quality plots with neat sketches. (6 Marks)

OR

18 (a) Describe the preventive measures to control saltwater intrusion into coastal aquifers with neat sketches. (7 Marks)

- (b) By conductivity measurements in a well in a coastal aquifer extending 4 km along the shore, the interface was located at a depth of 20 m below m.s.l. at 100 m from the shore, inland. The depth of the homogenous aquifer is 30 m below m.s.l. and has a permeability of 50 m/day. What is the rate of fresh water flow into the sea and the width of gap at the shore bottom through which it escapes into the sea? What is the position of the toe of the saltwater wedge? Use Glover's method. (7 Marks)

Module V

- 19 (a) Explain different techniques of artificial recharge of ground water with neat sketches. (8 Marks)
- (b) Find the numerical value of the third and fourth order aquifer head gradient by the forward, backward and central difference method assuming uniform head distribution in a confined aquifer between two wells located 4 Km apart with piezometric levels of 100 m and 102 m respectively. Take these two wells as the extreme nodes. (6 Marks)

OR

- 20.(a) One dimensional steady state flow is happening in a confined aquifer with transmissivity T . The aquifer is bounded by an impervious boundary to the left and a constant head boundary to the right. Ground water flows into the aquifer due to a constant recharge Q through an aquitard. Assuming $Q=0.0005\text{m/day}$, $T= 500 \text{ m/day}$, thickness of aquifer $b=100\text{m}$, length of aquifer $L= 5 \text{ Km}$, Constant head of right boundary $H=100 \text{ m}$, find the head at different nodes using central difference scheme.(Take discretization interval as 1250 m) (10 Marks)
- (b) Write any six applications of ground water models. (4 Marks)